



S501

FREESTANDING GAS FIREPLACE

OWNER'S MANUAL

WARRANTY REGISTRATION
enviro.com/warranty



WARNING: If the information in this manual is not followed exactly, a fire or explosion may result causing property damage, personal injury or loss of life. Installation and service must be performed by a qualified installer, service agency or the gas supplier.

CERTIFIED TO/CERTIFIÉ AUX: ANSI Z21.88 / CSA2.33 / CSA 2.17

SAFETY PRECAUTIONS



WARNING:

FIRE OR EXPLOSION HAZARD

Failure to follow safety warnings exactly could result in serious injury, death, or property damage.

- **Do not store or use gasoline or other flammable vapors and liquids in the vicinity of this or any other appliance.**

- **WHAT TO DO IF YOU SMELL GAS**
 - **Do not try to light any appliance.**
 - **Do not touch any electrical switch; do not use any phone in your building.**
 - **Leave the building immediately.**
 - **Immediately call your gas supplier from a neighbor's phone. Follow the gas supplier's instructions.**
 - **If you cannot reach your gas supplier, call the fire department.**

- **Installation and service must be performed by a qualified installer, service agency or the gas supplier.**

INSTALLER:

Leave this manual with the appliance.

CONSUMER:

Retain this manual for future reference.

This appliance may be installed in an after-market permanently located, manufactured (mobile) home, where not prohibited by local codes.

This appliance is only for use with the type of gas indicated on the rating plate. This appliance is not convertible for use with other gases, unless a certified kit is used.

Only doors certified with the appliance shall be used

Massachusetts installations (Warning): This product must be installed by a licensed plumber or gas fitter when installed within the Commonwealth of Massachusetts. Other Massachusetts code requirements: Flexible connector must not be longer than 36in., a shut off valve must be installed; only direct vent sealed combustion products are approved for bedrooms/bathrooms. A carbon monoxide detector is required in all rooms containing gas fired direct vent appliances. The fireplace damper must be removed or welded in the open position prior to installation of a fireplace insert.

SAFETY PRECAUTIONS

FOR SAFE INSTALLATION AND OPERATION OF YOUR "ENVIRO" HEATER, PLEASE CAREFULLY READ THE FOLLOWING INFORMATION:

- All ENVIRO gas-fired appliances must be installed in accordance with their instructions. Carefully read all the instructions in this manual first. Consult the building authority having jurisdiction to determine the need for a permit prior to commencing the installation.
- **NOTE:** Failure to follow these instructions could cause a malfunction of the fireplace, which could result in death, serious bodily injury, and/or property damage.
- Failure to follow these instructions may also void your fire insurance and/or warranty.

GENERAL

• Installation and repair should be done by a qualified service person. The appliance should be inspected before the first use and, at least, annually by a qualified service person. More frequent cleaning may be required due to excessive lint from carpeting, bedding material, etc. It is imperative the control compartments, burners and circulating air passageways of the appliance be kept clean.

• Due to high temperatures, the appliance should be located out of high traffic areas and away from furniture and draperies.

Children and adults should be alerted to the hazards of high surface temperatures and should stay away to avoid burn or clothing ignition.

• Young children should be carefully supervised when in the same room as the appliance. Toddlers, young children and others may be susceptible to accidental contact burns. A physical barrier is required if there are at risk individuals in the house. To restrict access to a fireplace or stove install an adjustable safety gate to keep toddlers, young children and other at risk individuals out of the room and away from hot surfaces. Any safety screen, guard, or barrier removed for servicing an appliance must be replaced prior to operating the appliance.

• Clothing or other flammable materials should not be placed on or near the appliance.

• A barrier designed to reduce the risk of burns from the hot viewing glass is provided with this appliance and shall be installed for the protection of children and other at-risk individuals. If the barrier becomes damaged, the barrier shall be replaced with the manufacturer's barrier for this appliance

FOR YOUR SAFETY

• Installation and service must be performed by a qualified installer, service agency or gas supplier.

• This installation must conform to local codes or, in the absence of local codes, with the National Fuel Gas Code, ANSI Z223.1/NFPA 54, or the Natural Gas and Propane Installation Code, CSA B149.1.

• To prevent injury, do not allow anyone who is unfamiliar with the stove to operate it.

• To prevent injury, if the pilot or pilot and burners have gone out on their own, open the glass door and wait 5 minutes to air out before attempting to re-light the stove.

• Always keep the area around these appliances clear of combustible material, gasoline and other flammable liquids and vapours.

• These appliances should not be used as a drying rack for clothing or for hanging Christmas stockings/decorations.

• Due to the paint curing on the stove, a faint odor and slight smoking will likely be noticed when the stove is first used. Open a window until the smoking stops.

Always connect this gas stove to a vent system and vent to the outside of the building envelope. Never vent to another room or inside the building. Make sure the specified vent pipe is used, properly sized and of adequate height to provide sufficient draft. Inspect the venting system annually for blockage and signs of deterioration.

WARNING: Failure to position the parts in accordance with the diagrams in this booklet, or failure to use only parts specifically approved with this appliance, may result in property damage or personal injury.

WARNING: Do not operate with the glass front removed, cracked or broken. Replacement of the glass should be done by a licensed or qualified service person.

• Never use solid fuels such as wood, paper, cardboard, coal, or any flammable liquids, etc., in this appliance.

• Do not use this appliance if any part has been under water. Immediately call a qualified service technician to inspect the appliance and to replace any part of the control system or any gas control which has been under water.

• Do not abuse the glass by striking it or slamming the door shut.

• If the S50I unit is pulled out of its installation, and the vent-air intake system is disconnected for any reason, ensure that the vent-air intake pipes are reconnected and re-sealed in accordance to the instructions noted in DIRECT VENT section on page 28.



DANGER



HOT GLASS WILL CAUSE BURNS

DO NOT TOUCH GLASS UNTIL COOLED.

NEVER ALLOW CHILDREN TO TOUCH GLASS.

A barrier designed to reduce the risk of burns from the hot viewing glass is provided with this appliance and must be installed for the protection of children and other at-risk individuals.

TABLE OF CONTENTS

Safety Precautions	2
Table of Contents	4
Codes And Approvals	6
Specifications	7
Dimensions:	7
Rating Label & Lighting Instructions Location..	7
Operating Instructions	8
Lighting and Turning Off Instructions	8
Air Shutter	9
Normal Sounds During Operation	9
Remote Control Operations	9
System Description	10
Technical Data	10
Transmitter	10
Integrated Fireplace Controller (IFC):..	11
Operating Procedure:	11
Switching to Continuous Pilot Mode:	12
Routine Maintenance	14
Maintenance And Service	15
Lifting the Top Plate	15
Safety Screen	16
Removing the Door Frame/Skirt..	17
Removing the Glass	18
Removing the Rear Chassis	19
Top Light Replacement	20
Optional Fan Replacement (50-4247)	20
Replacing Trim Parts	21
Removing Top Plate	23
Burner Removal.....	23
Fuel Conversion.....	24
Initial Installation	26
Preparation for Installation	26
Clearance to Combustibles	27
Direct Vent.....	28
Venting Clearances	28
Approved Venting Parts	28
Vent Termination Restrictions	30
Exhaust Restrictor Settings	31
Minimum Top Vent Configurations	32
Top Vent Configuration - Natural Gas (NG)	33
Top Vent Configuration - Propane (LP)	34
Minimum Rear Vent Configurations	35
Rear Vent - Corner Installation	36

TABLE OF CONTENTS

Horizontal Termination	37
Vertical Termination	38
Gas Line Connection	41
Electrical Requirements	42
Top Plate Collar Installation	43
Rear Vent Conversion	43
Pedestal Installation	46
Moblile Home Istallation	48
Relocating Gas/Electrical	49
Secondary Installation	52
Log Set Installation	52
Media Installation	54
Trouble Shooting	55
Parts List	57
Installation Data Sheet	60

CODES AND APPROVALS

DIRECT VENT ONLY: This type is identified by the suffix DV. This appliance draws all of its air for combustion from outside the dwelling, through a specially designed vent pipe system.

This appliance has been tested and approved for installations from 0 feet to 4500 feet (1372 m) above sea level.

In the USA: The appliance may be installed at higher altitudes. Please refer to your American Gas Association guidelines which state: the sea level rated input of Gas Designed Appliances installed at elevations above 2000 (610 m) feet is to be reduced 4% for each 1000 feet (305 m) above sea level. Refer also to local authorities or codes which have jurisdiction in your area regarding the de-rate guidelines.

In Canada: When the appliance is installed at elevations above 4500 feet (1372 m), the certified high altitude rating shall be reduced at the rate of 4% for each additional 1000 feet (305 m).

- This appliance has been tested by INTERTEK and found to comply with the established VENTED GAS FIREPLACE HEATER standards in CANADA and the USA as follows:

VENTED GAS FIREPLACE HEATER
TESTED AND LISTED TO: ANSI Z21.88 / CSA 2.33 VENTED GAS FIREPLACE
HEATERS
CSA 2.17 GAS FIRED APPLIANCES FOR HIGH ALTITUDES
CSA P.4.1 TESTING METHOD FOR MEASURING ANNUAL FIREPLACE
EFFICIENCY

This ENVIRO S50I Fireplace:

- Has been certified for use with either natural or propane gases. (See rating label.)
- Is not for use with solid fuels.
- Is approved for bedroom or bed sitting room. (**IN CANADA:** must be installed with a listed wall thermostat. **IN USA:** see current ANSI Z223.1 for installation instructions.)
- Must be installed in accordance with local codes. If none exist, use current installation code CAN/CGA B149.1 in Canada or ANSI Z223.1/NFPA 54 in the USA.
- Must be properly connected to an approved venting system and not connected to a chimney flue serving a separate solid-fuel burning appliance.

IMPORTANT NOTICE (Regarding first fire up): When the unit is turned on for the first time, it should be turned onto high without the fan on for the first 4 hours. This will cure the paint, logs, gasket material and other products used in the manufacturing process. It is advisable to open a window or door, as the unit will start to smoke and can irritate some people. After the unit has gone through the first burn, turn the unit off including the pilot, let the unit get cold then remove the glass door and clean it with a good gas fireplace glass cleaner, available at your local ENVIRO dealer.



SPECIFICATIONS

DIMENSIONS:

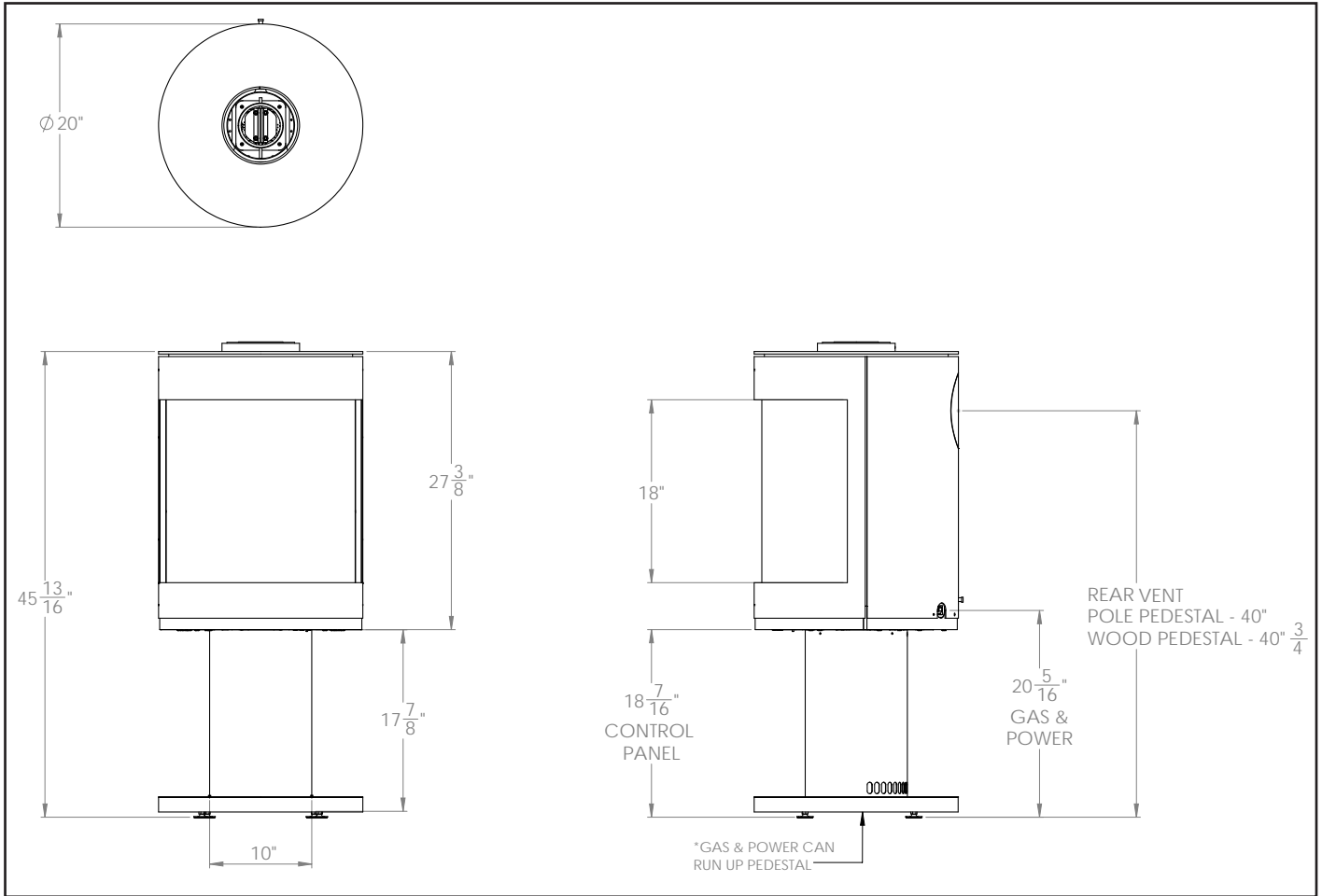

Figure 1: S50 Dimensions

RATING LABEL & LIGHTING INSTRUCTIONS LOCATION

The rating label and lighting instruction booklet is located inside the unit. The fireplace door frame must be removed for access. Refer to page 17 for instructions on door frame removal. The booklet can be found attached to a tether at the back of the component tray. This area can be accessed through the opening shown in Figure 2.

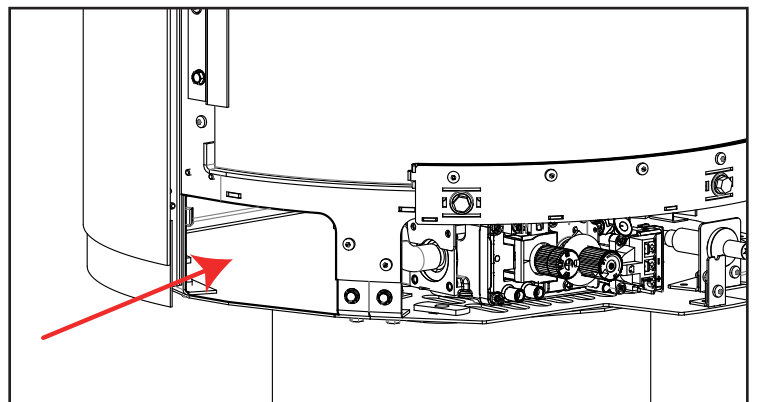

Figure 2: Rating/Lighting Booklet Location

OPERATING INSTRUCTIONS

For Your Safety, Read Safety Precautions And Lighting Instructions Before Operating

WARNING: IF YOU DO NOT FOLLOW THESE INSTRUCTIONS EXACTLY A FIRE OR EXPLOSION MAY RESULT, CAUSING PROPERTY DAMAGE, PERSONAL INJURY OR LOSS OF LIFE.

LIGHTING AND TURNING OFF INSTRUCTIONS

FOR YOUR SAFETY READ BEFORE OPERATING

WARNING: IF YOU DO NOT FOLLOW THESE INSTRUCTIONS EXACTLY, A FIRE OR EXPLOSION MAY RESULT CAUSING PROPERTY DAMAGE, PERSONAL INJURY OR LOSS OF LIFE.

- A. This appliance is equipped with an ignition device which automatically lights the pilot. Do not try to light the pilot by hand.
- B. BEFORE OPERATING smell all around the appliance area for gas. Be sure to smell next to the floor because some gas is heavier than air and will settle on the floor.
- WHAT TO DO IF YOU SMELL GAS:
- Do not try to light any appliance.
 - Do not touch any electrical switch; do not use any phone in your building.
 - Immediately call your gas supplier from a neighbor's phone. Follow the gas supplier's instructions.
 - If you cannot reach your gas supplier, call the fire department.
- C. Use only your hand to push in or turn the gas control knob. Never use tools. If the knob will not push in or turn by hand, don't try to repair it, call a qualified service technician. Force or attempted repair may result in a fire explosion.
- D. Do not use this appliance if any part has been under water. Immediately call a qualified service technician to inspect the appliance and to replace any part of the control system and any gas control which has been under water.

TO TURN OFF GAS TO APPLIANCE

1. Set thermostat to lowest setting, or press the ON/OFF Key. "OFF" will be indicated on the display and an audible "Beep" will be heard at the unit to indicate the command has been received.
2. Turn off all electric power to the appliance if service is to be performed.

C-16303

OPERATING INSTRUCTIONS

1. STOP! Read the safety information above on this label.
2. Read the owner's manual including the section on "Remote Control" operation.
3. Set the thermostat to the lowest setting.
4. Turn off all electric power to the appliance.
5. Do not attempt to light the pilot by hand.
6. Wait five (5) minutes to clear out any gas. Then smell for gas, including near the floor. If you smell gas, STOP! Follow "B" in the safety information above on this label. If you don't smell gas, go to the next step.
7. Turn on all electric power to the appliance.
8. Using the remote control, set thermostat to desired setting, or npress the ON/OFF key on the remote. "ON" will be indicated on the display of the remote and an audible "beep" will be heard at the unit to indicate the command has been received.
9. This appliance is equipped with a completely automatic ignition and lighting control. The control will attempt to light the pilot several times if necessary. If it is unsuccessful, it will continue operations. If the appliance will not operate, follow the instructions "To Turn Off Gas To Appliance" and call your service technician or gas supplier.

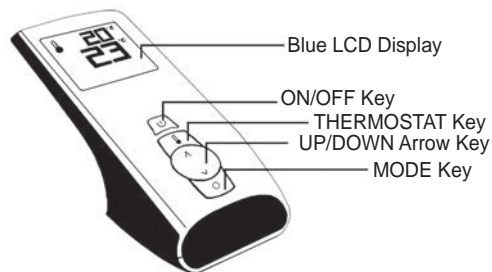

C-16303

Figure 3: S50I Lighting Instruction Labels

OPERATING INSTRUCTIONS

AIR SHUTTER

The air shutter plays a very important role in flame appearance and combustion quality. The shutter adjusts how much air gets mixed with the gas before it ignites. Start the fireplace and allow it to heat up for 15+ minutes before making adjustments.

The air shutter slider is located at the back of the unit (see Figure 4).

Adjustments:

Lean (more primary air): Pull slider outwards to make flame appear more blue and low.

Rich (less primary air): Push slider inward to make flame appear more yellow and tall. Flame will continue to richen up during operation creating a potential for gradual soot build-up.

Note: If you cannot attain a healthy flame by making air shutter adjustments, you may have the incorrect restrictor setting or a venting problem.

Warning: Incorrect shutter adjustment may lead to improper combustion, which is a safety hazard. Contact the dealer if there is any concern about the venturi adjustment.

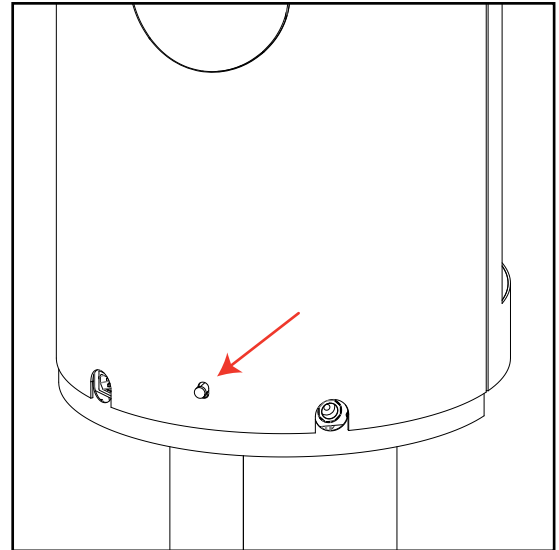

Figure 4: Air Shutter Location

***NOTE:** When the unit is turned on for the first time, it should be turned onto high, with the fan OFF, for the first two to four hours. This will cure the paint, logs, gasket material, and other products used in the manufacturing process. It is advised that a door or window be opened as the unit will start to smoke, which can irritate some people. After the unit has gone through the first burn turn the unit OFF, including the pilot, and let the unit get completely cold. Then remove the glass and clean it with a good gas fireplace glass cleaner, available at your local Enviro dealer. See page 17 and page 18 for instructions on removing fireplace door and glass.

NORMAL SOUNDS DURING OPERATION

Table 1: Normal Sounds

Component	Sound & Reason
Firebox	Creaking when heating up or cooling down.
Burner	Pop or poof when turned off; this is more common with LP units.
Pilot Flame	Quiet whisper while the pilot flame in on.
Fan	Fan moving air during operation.
Gas Control Valve	Dull click when turning on or off, this is the valve opening and closing.

REMOTE CONTROL OPERATIONS

Proflame 2 is a modular remote control system that directs the functions of the S50I. The Proflame 2 TMFSLA is configured to control the on/off main burner operation, its flame levels and provides on/off and Smart thermostatic control of the appliance. The system also controls the fan speed through six (6) levels.

OPERATING INSTRUCTIONS

SYSTEM DESCRIPTION

The Proflame 2 Remote Control System consists of two (2) elements:

1. Proflame 2 Transmitter.
2. Integrated Fireplace Controller (IFC) and a wiring harness to connect to the gas valve and stepper motor.

ATTENTION!

- TURN "OFF" THE MAIN GAS SUPPLY OF THE APPLIANCE DURING INSTALLATION OR MAINTENANCE OF THE IFC.
- TURN "OFF" MAIN GAS SUPPLY TO THE APPLIANCE PRIOR TO REMOVING OR REINSERTING THE BATTERIES IN THE BATTERY HOLDER

TECHNICAL DATA

Transmitter (Remote Control):

Supply voltage: 4.5 V (three 1.5 V AAA batteries)
Radio frequency: 315 MHz

Integrated Fireplace Controller (IFC):

Supply voltage: AC IN - 120 V / 60 Hz
Battery Backup IN - 6 Vdc - 200mA (four 1.5 V AA batteries)
Spark voltage / frequency: >10kV / 1Hz
Comfort modulating fan: 120 V / 60 Hz / 2A
Auxiliary: 120 V / 60 Hz / 5A

TRANSMITTER

The Proflame 2 Transmitter is a black remote control with a blue backlit lcd display. It uses a streamline design with a simple button layout and informative lcd readout (Figure 5). The Transmitter is powered by three (3) AAA type batteries. A Mode Key is provided to Index between the features and a Thermostat Key is used to turn on/off or index through Thermostat functions (Figure 5 & Figure 6)



Figure 5: Proflame 2 Transmitter

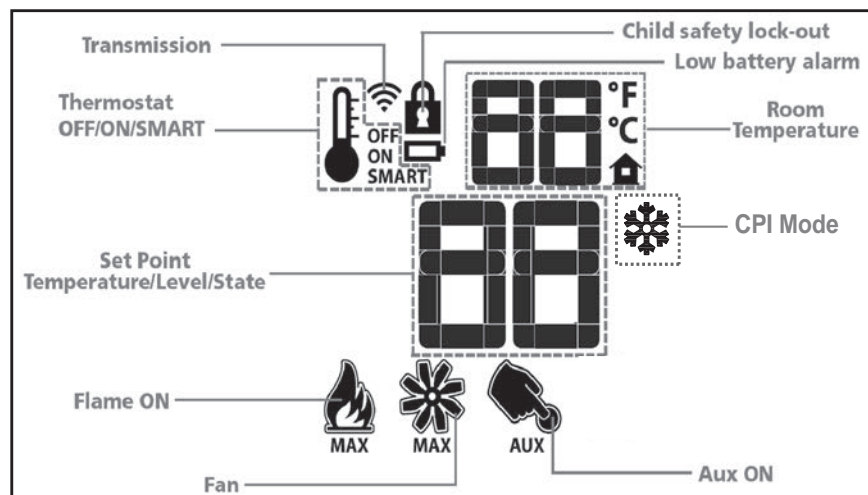

Figure 6: Proflame 2 Transmitter LCD Screen.

OPERATING INSTRUCTIONS

INTEGRATED FIREPLACE CONTROLLER (IFC):

The Proflame 2 IFC (Figure 7) connects directly to the gas valve, stepper motor, pilot and convection fan with a wiring harness. The IFC is mainly powered by 120 VAC but can also run off a battery backup four (4) AA type batteries for shorter periods of time. The IFC accepts commands via radio frequency from the Transmitter to operate the appliance in accordance with the particular Proflame 2 system configuration. The IFC has a reset button located underneath the front skirt of the unit (see Figure 9). This button is used to synchronize the Transmitter when using for the first time, or after the batteries have been replaced.

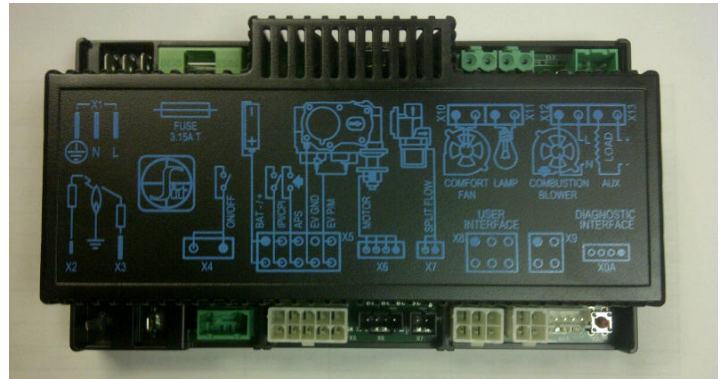

Figure 7: Integrated Fireplace Controller

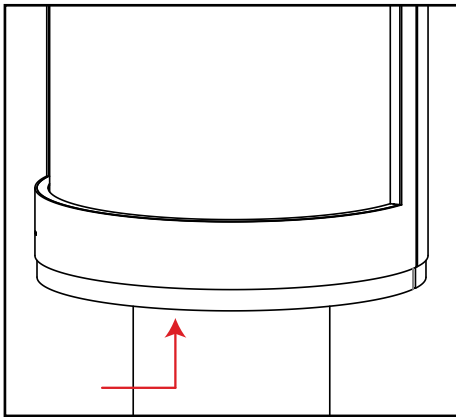

Figure 8: Controls Location

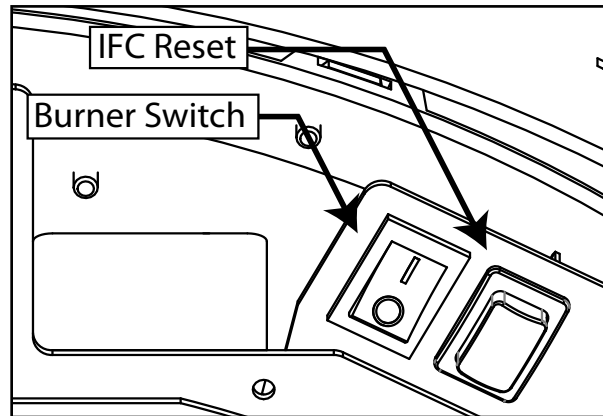

Figure 9: Controls Location (Bottom View)

OPERATING PROCEDURE:

Initializing The System For The First Time

Install the four (4) AA batteries into the IFC battery holder. Note the polarity of the battery and insert into the battery bay as indicated on the body of the battery holder. Press the reset button on the IFC marked "SW1" (see Figure 6).

The IFC will "beep" three (3) times to indicate that it is ready to synchronize with a Transmitter. Install the three (3) AAA type batteries in the Transmitter battery bay, located on the base of the Transmitter. With the batteries already installed in the Transmitter, push the 'ON' button. The IFC will "beep" four (4) times to indicate the Transmitter's command is accepted and sets to the particular code of that Transmitter. The system is now initialized.

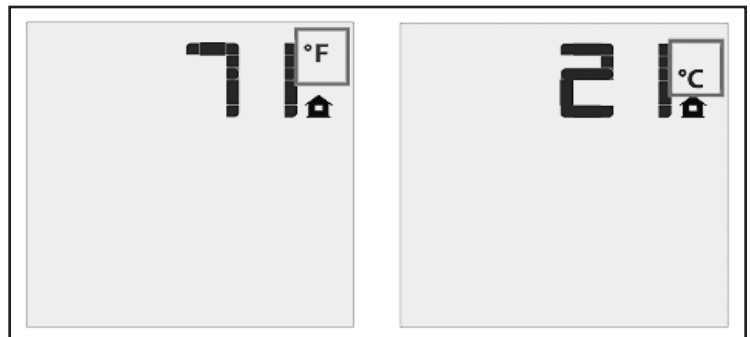

Figure 10: Remote Control Display in Fahrenheit and Celcius

OPERATING INSTRUCTIONS

Temperature Indication Display

With the system in the "OFF" position, press the Thermostat Key and the Mode Key at the same time. Look at the LCD screen on the transmitter to verify that a °C or °F is visible to the right of the Room Temperature display (see Figure 7).

Turn on the Appliance

Press the ON/OFF Key on the Transmitter. The Transmitter display will show all active Icons on the screen. A single "beep" from the IFC will confirm reception of the command and will commence to first ignite the pilot light, followed by the main burner. This should take about 10 seconds to complete.

SWITCHING TO CONTINUOUS PILOT MODE:

When the S20I is turned off press the mode key to index to the constant pilot (CPI) mode icon (see figure 8). Pressing the up arrow key will select Continuous Pilot Ignition (CPI) and pressing the down arrow key will return to IPI. Once a selection is made the IFC will beep once to confirm it had received the command. **NOTE: It is recommended to use the continuous pilot mode during the winter when the outside temperature is below 50°F (10°C) to keep the chimney properly heated for updraft during burner ignition.** Continuous

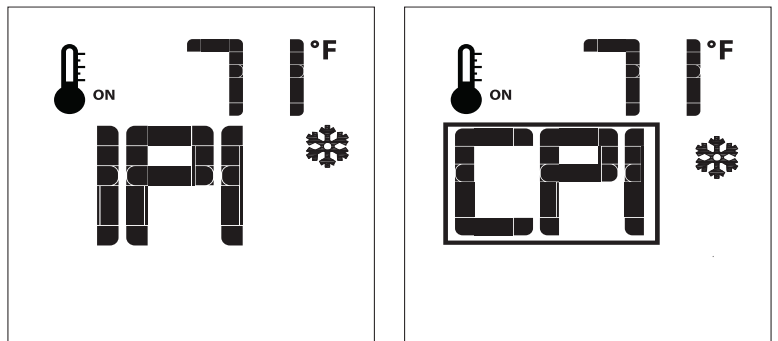

Figure 11: CPI Pilot Mode.

pilot mode also keeps the firebox warm which eliminates both heat loss to cold air that is trapped inside the firebox as well as excessive exhaust vapour condensation on the door glass.

Turn off the Appliance

Press the ON/OFF Key on the Transmitter. The Transmitter LCD display will only show the room temperature and Icon (see Figure 9). A single "beep" from the IFC confirms reception of the command and both the pilot light (if the unit is not set to continuous pilot) and main burner will turn off.

Room Thermostat (Transmitter Operation)

The Remote Control can operate as a room thermostat. The thermostat can be set to a desired temperature to control the comfort level in a room. To activate this function, press the Thermostat Key (see Figure 4). The LCD display on the Transmitter will change to show that the room thermostat is "ON" and the set temperature is now displayed (see Figure 9). To adjust the set temperature, press the Up or Down Arrow Keys until the desired set temperature is displayed on the LCD screen of the Transmitter.

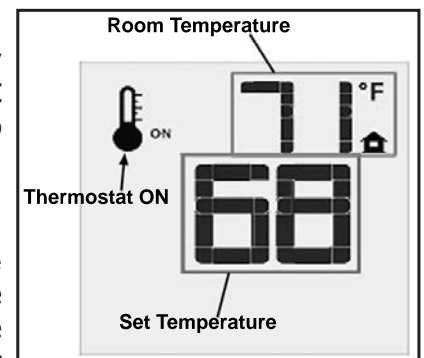

Figure 12: Remote Control Displays Set Temperature.

Smart Thermostat (Transmitter Operation)

The Smart Thermostat function adjusts the flame height in accordance to the difference between the set point temperature and the actual room temperatures. As the room temperature gets closer to the set point the Smart Function will modulate the flame down. To activate this function, press the Thermostat Key (Figure 4) until the word "SMART" appears to the right of the temperature bulb graphic (Figure 10). To adjust the set temperature, press the Up or Down Arrow Keys until the desired set temperature is displayed on the LCD screen of the Transmitter.

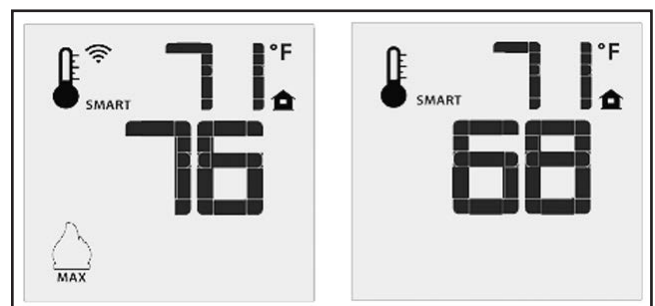

Figure 13: Remote Control's Smart Flame Function.

OPERATING INSTRUCTIONS

Remote Flame Control

The Proflame 2 GTMF has six (6) flame levels. With the system on, and the flame level at the maximum in the appliance, pressing the Down Arrow Key once will reduce the flame height by one step until the flame is turned off. The Up Arrow Key will increase the flame height each time it is pressed. If the Up Arrow Key is pressed while the system is on but the flame is off, the flame will come on in the high position (refer to Figure 11). A single "beep" will confirm reception of the command.

Fan Control

The S20I comes with a convection fan that can be controlled with the Transmitter. The fan speed can be adjusted through six (6) speeds. To control the fan press the MODE key (Figure 4) to index to the fan control icon (Figure 12). Use the UP/DOWN arrow keys to turn on, off, or adjust the fan speed (Figure 12). A single beep from the IFC will confirm the command has been received.

Top Light Control

The firebox toplight can be controlled with the Transmitter. The light is non-adjustable but can be turned on and off as desired. To control the top light press the MODE key (Figure 5) to index to the AUX control icon (Figure 16). Use the UP/DOWN arrow keys to turn the light on or off. A single beep from the IFC will confirm the command has been received. The top light is most noticeable when the flame is set to the lowest setting. It can also be left on when the flame is off (see Remote Flame Control section) to highlight the log set.

For more information regarding the Top Light, refer to MAINTENANCE AND SERVICE - TOP LIGHT REPLACEMENT on page 20.

Key lock

This function will lock the keys to avoid unsupervised operation. To activate this function, press the MODE and UP keys at the same time and the a lock will appear (see Figure 17). To de-activate this function, press the MODE and UP Keys at the same time.

Low Battery Power Detection

Transmitter: The life span of the remote control batteries depends on various factors: quality of the batteries used, the number of ignitions of the appliance, the number of changes to the room thermostat set point, etc. When the Transmitter batteries are low, a Battery Icon will appear on the LCD display of the Transmitter (see Figure 18) before all battery power is lost. When the batteries are replaced this Icon will disappear.

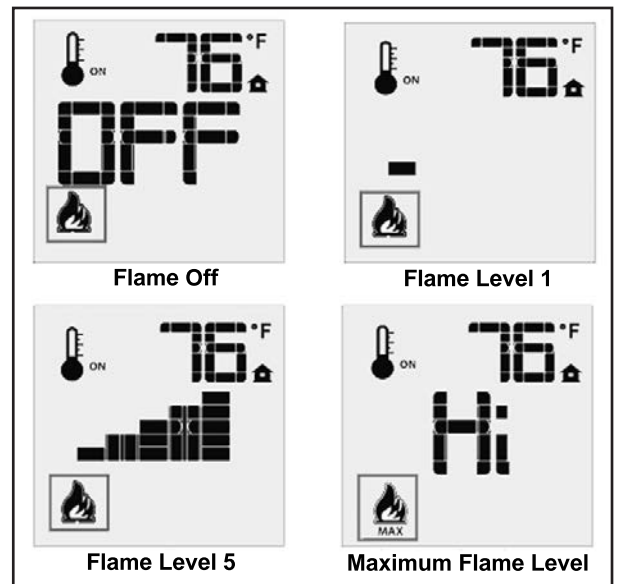

Figure 14: Remote Control's Flame Levels.

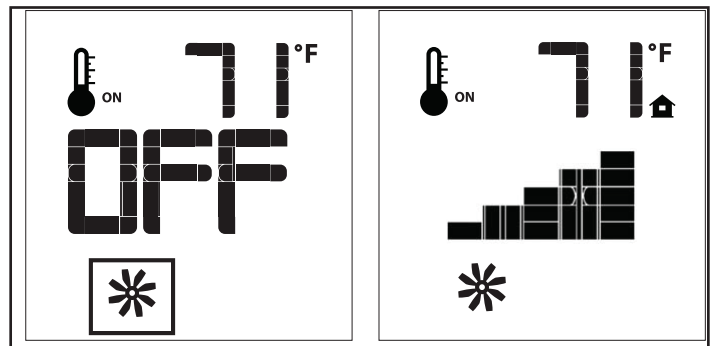

Figure 15: Fan Control

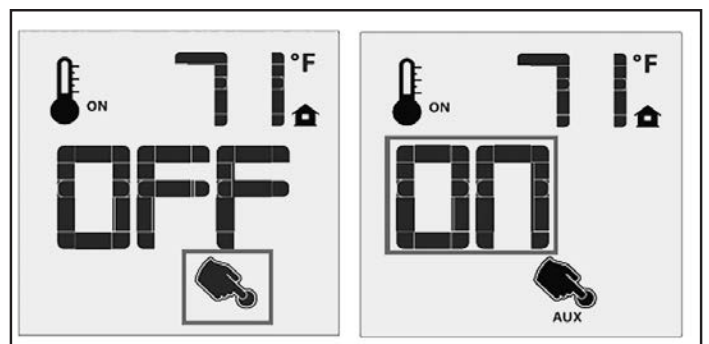

Figure 16: Remote Control with Aux (Top Light)

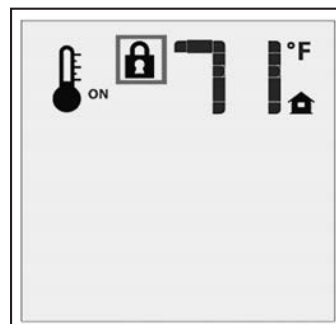

Figure 17: Remote Control Locked



Figure 18: Low Battery Indicator

OPERATING INSTRUCTIONS

IFC: The life span of the IFC batteries depends on various factors during a prolonged power outage: quality of the batteries used, the number of ignitions of the appliance, the number of changes to the room thermostat set point etc. When the IFC batteries are low, No "beep" will be emitted when it receives an On/Off command from the Transmitter. This is an alert for a low battery condition for the IFC. When the batteries are replaced the "beep" will be emitted from the IFC when the ON/OFF Key is pressed (See INITIALIZING THE SYSTEM FOR THE FIRST TIME on page 11).

WARNING: Fire Hazard. Can cause severe injury or death. The IFC causes ignition of the appliance. The appliance can turn on suddenly. Keep away from the appliance burner when operating the remote system or activating manual by pass of the remote system.

WARNING: Shock Hazard. Can cause severe injury or death. This device is powered by line voltage. Do not try to repair this device. In no way is the enclosure to be tampered with or opened. Disconnect from line voltage before performing any maintenance.

WARNING: Devices rated more than 5A shall not be connected to the OUT receptacle. Devices rated more than 1A shall not be connected to the FAN receptacle. Devices rated more than 2A shall not be connected to the AUX receptacle.

CAUTION: Property Damage Hazard. Excessive heat can cause property damage. The appliance can stay lit for many hours. Turn off the appliance if it is not going to be attended for any length of time. Always place the Transmitter where children cannot reach it.

ROUTINE MAINTENANCE

At least once a year, run through the following procedures to ensure the system is clean and working properly. Check the burner to see if all the ports are clear and clean. Check the pilot to make sure it is not blocked by anything. The pilot flame should be blue with little or no yellow on the tips.

WARNING: Failure to position the parts in accordance with this manual, or failure to use only parts specifically approved with this appliance may result in property damage or personal injury.

The venting system must be periodically examined; it is recommended the examination is done by a qualified agency.

CLEANING DECORATIVE SURFACES

Powder coated surfaces: ONLY USE WARM SOAPY WATER and microfiber cloth (paper towel can leave scratches). Chemical cleaners will damage the coating and replacement due to chemical cleaning is NOT covered under warranty.

Enameled liner surfaces: Use a ceramic cleaner with ceramic cleaning sponge or microfiber cloth.

CLEANING THE GLASS

WARNING: Do not clean glass when hot; allow unit to cool completely before disassembling.

Remove the door frame and glass (see details on page 17 and page 18 respectively). Check the gasket material is intact and the adhesive hasnt worn off.

Condensation will sometimes form on the glass during cold starts, this is a normal condition with all fireplaces. This condensation will eventually leave residue which requires cleaning. Initial firebox paint curing can leave a slight film behind the glass which poses a temporary problem; thus the glass may need cleaning about two weeks after installation. Use a mild glass cleaner and a soft cloth. Abrasive cleaners will damage the glass and painted surfaces. Clean glass as needed.

MAINTENANCE AND SERVICE

LIFTING THE TOP PLATE

The top plate of the unit is attached to 4 slotted supporting tabs. Lift the top plate upwards until it stops, then twist the top plate clockwise to set it in lock position. (See Figure 19 and 20 below).

NOTE: Lift the top plate evenly to make sure all 4 pins and tabs are leveled while twisting the top plate.

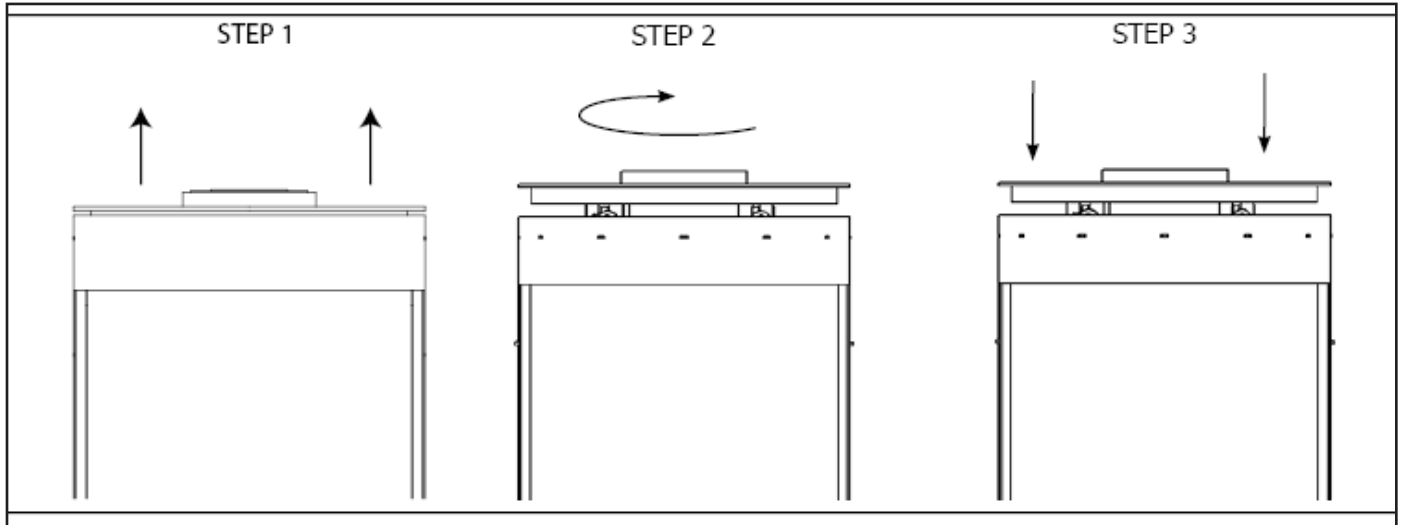

Figure 19: Lifting the Top Plate

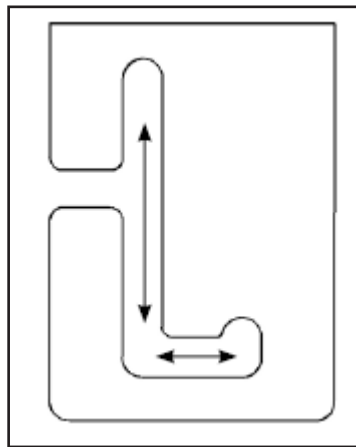

Figure 20: Top Plate Lift Slot Mechanism

MAINTENANCE AND SERVICE

SAFETY SCREEN

The safety screen is attached by two hooks on the top edge of the unit (see Figure 21). Lift top plate to gain safety screen lift clearance (see instruction previous page); gently and carefully lift the screen up and away from the unit (see Figure 22).

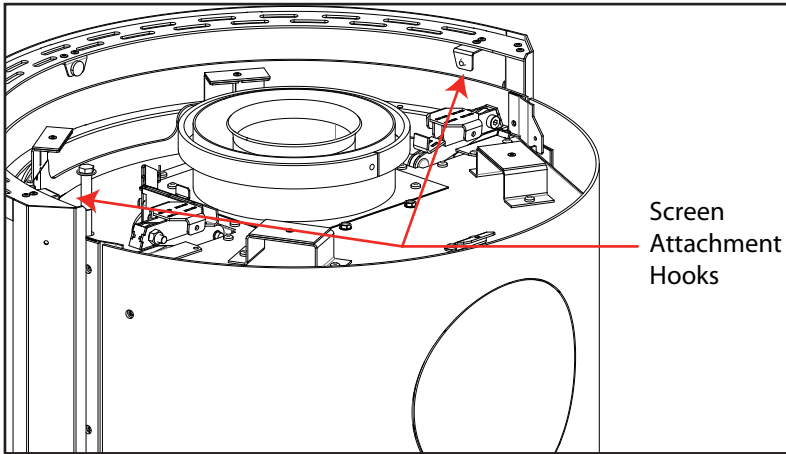

Figure 21: Safety Screen Attachment Hooks (Top Plate Removed for Visibility)

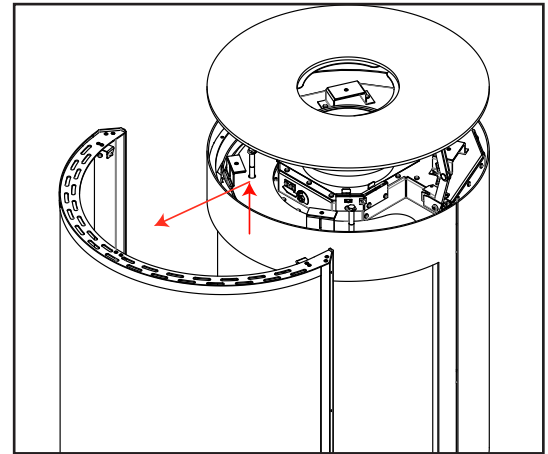

Figure 22: Safety Screen Removal

***NOTE:** The screen uses rubber bumpers as a cushion between it and the main body of the fireplace to prevent damage to the exterior. Even with these in place, it is important to be very careful when removing/attaching the safety screen as to not scratch or chip the paint.

Safety Screen Positioning: The two upper side hooks mount over the door frame. The center bumper rests on the OUTSIDE of the door frame (see Figure 23 for clarification). The lower three standoff bumpers also rest against the outer surface. Take care not to scratch any painted surfaces.

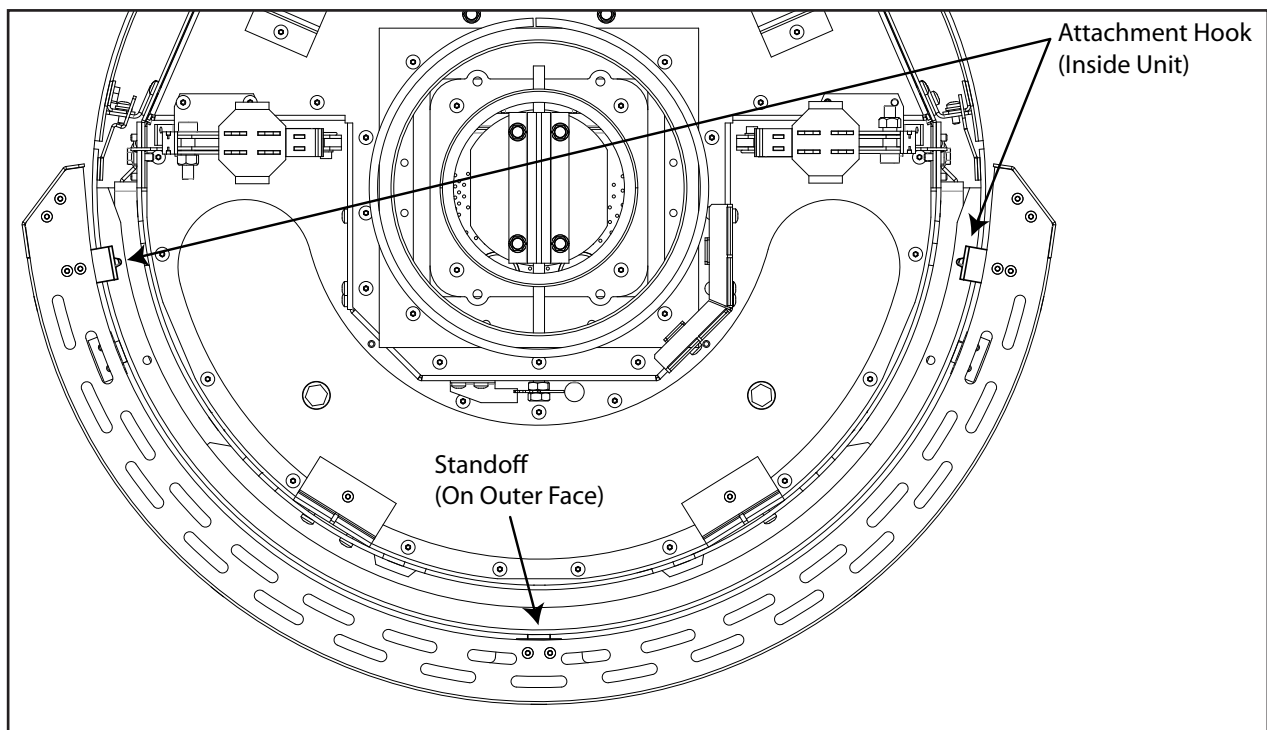

Figure 23: Safety Screen Attachment (Top-Down View)

MAINTENANCE AND SERVICE

The safety screen mounting position can be adjusted slightly to maintain parallelism with the fireplace body lines. The outer standoffs on the lower screen can be repositioned by loosening the two T20 screws and adjusting via slots, retighten screws.

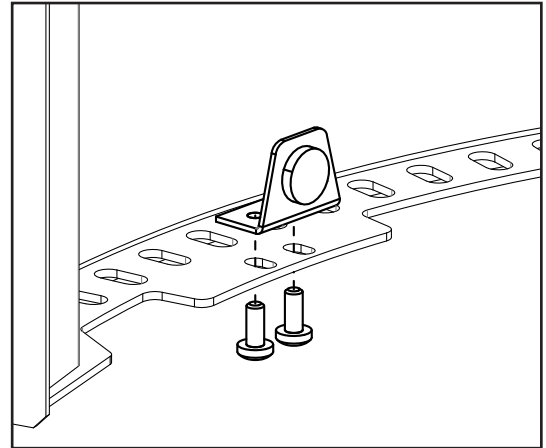

Figure 24: Safety Screen Adjustments

REMOVING THE DOOR FRAME/SKIRT

The door frame and skirt will need to be removed to gain firebox and component access. Take care not to scratch any painted surfaces.

REMOVING/MOUNTING THE DOOR FRAME

The door frame is attached with four hooks (two on each side) that interlock with slots on the chassis.

Remove: Lift top plate and set support hinges (see "Lifting The Top Plate" section for details), then grab the frame on either side and lift up to disengage hooks and bring out.

Mounting: There are two different sections in each mounting slot (see Figure 25). The door frame should fit relatively easily into section 1, it may be easier to mount one side first then the other. Once all hooks are engaged in their respective slots, push in one side of the door frame (top and bottom) until the hooks drop into the section 2; repeat this on the opposite side. This will firmly lock the door frame into position and close up any excessive gaps.

NOTE: If door frame mounting is proving difficult, the curved glass may not be clamped properly creating and interference with the door frame.

REMOVING THE FRONT SKIRT

Remove: After the door frame is removed, the skirt can be removed to gain component access by lifting up at either end to disengage the hooks and brought out.

Mounting: Place the skirt hooks into their respective chassis slots and the center stud support rest in the finger groove. Ensure proper hook setting is used for your pedestal option.

The notches closest to the end of the hook should be used when installed with a pole pedestal. The notches closest to the body of the skirt should be used when installed with a wood pedestal (see Figure 27 for detailed view).

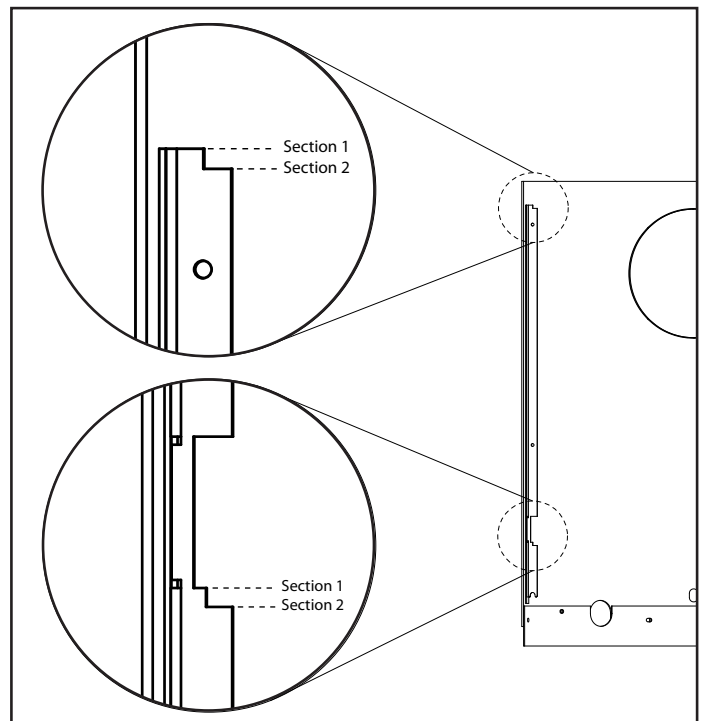

Figure 25: Chassis Mounting Slots

MAINTENANCE AND SERVICE

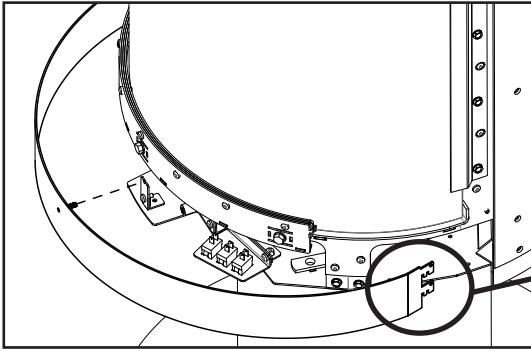

Figure 26: Front Skirt Attachment

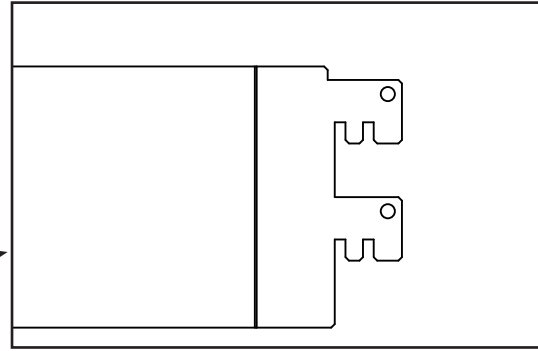

Figure 27: Front Skirt Hooks

REMOVING THE GLASS

WARNING: No substitute materials or parts can be used. **ONLY** glass supplied from the manufacturer may be used (replacement part number: 50-4188).

Remove the door frame (see previous section for details). The curved glass is retained using four clamps: one on each side, one on the top and bottom. To remove the glass: Loosen the two side retainers using a 5/16" socket (see Figure 28). Next, fully remove the top and bottom curved retainers using a 3/8" socket (see Figure 29). Shimmy the glass forward then grab it top and bottom by hand and carefully remove.

***NOTE:** To reattach the glass, perform the above instructions in reverse order. **IT IS IMPORTANT THAT THE TOP AND BOTTOM RETAINERS ARE INSTALLED FIRST AND FULLY TIGHTENED.** Not doing so can result in door frame mounting interference.

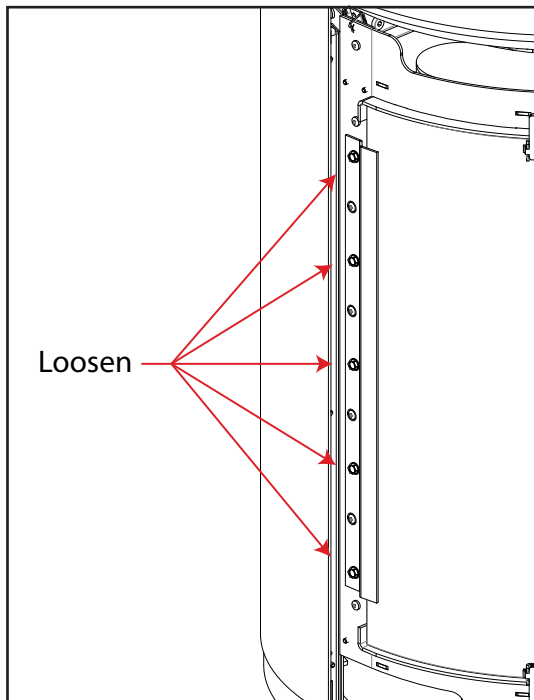

Figure 28: Glass Side Retainer

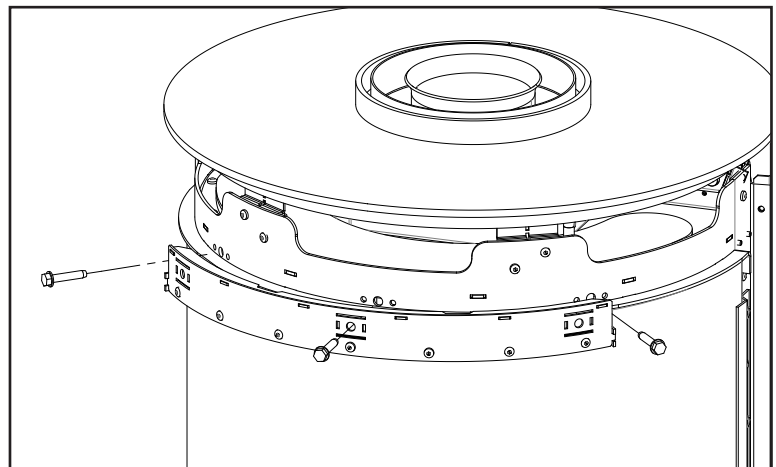

Figure 29: Glass Top/Bottom Retainer

MAINTENANCE AND SERVICE

REMOVING THE REAR CHASSIS

1. Remove the door frame and skirt (see REMOVING DOOR FRAME/SKIRT section on page 17).
2. Remove the venturi knob located on the back of the unit (see Figure 4). It can be unscrewed by hand and put aside.
3. Position yourself in a way that allows you to support the chassis once detached. Remove the four mounting screws using a 5/16" socket (see Figure 30). There are two spacers at the bottom on the backside that support the rear chassis weight (see Figure 31). The chassis will pivot backwards once fully detached.
4. Lift up to disengage the slot from the spacers and pull away from the unit (See Figure 32).

When remounting, position chassis slots over both spacers and pivot up and reattach screws. Due to mild warping, the chassis may need to be squeezed inward to align slots.

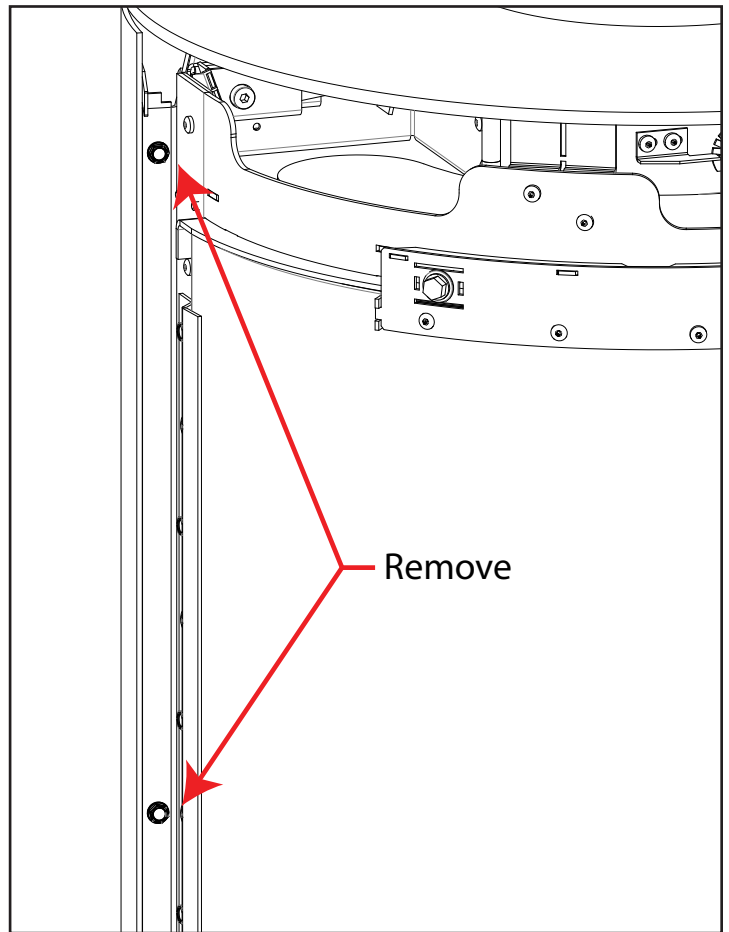

Figure 30: Rear Chassis Detachment

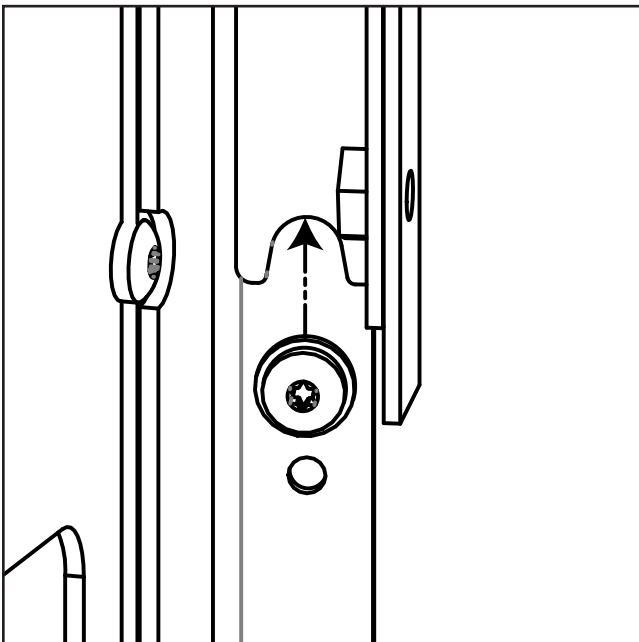

Figure 31: Rear Chassis Spacers

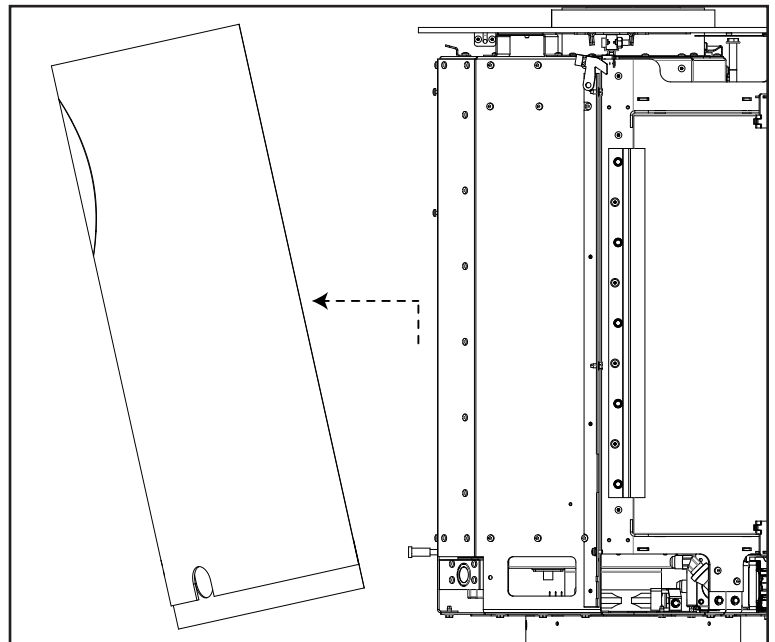

Figure 32: Rear Chassis Removal

MAINTENANCE AND SERVICE

TOP LIGHT REPLACEMENT

Top light replacement bulb: G9 25W 120V (50-4119). Disconnect power cord before proceeding. To replace the bulb, first remove the door frame and curved glass (see page 17 and page 18 for details). Remove top light cover plate (see Figure 33) take care not to damage ceramic fiber gasket, replace if needed. Gently lower the top light assembly and let it hang from the wires. Grab the top light glass on either side at the end with the two metal finger retainers and pull, the glass should rotate outward. Remove bulb by hand, be careful not to break it. Replace bulb taking caution never to touch the bulb with bare fingers. Use the foam sleeve provided to handle the bulb or wear clean gloves. Reassemble top light in the reverse order, attach spring clip to glass before reclipping to casing.

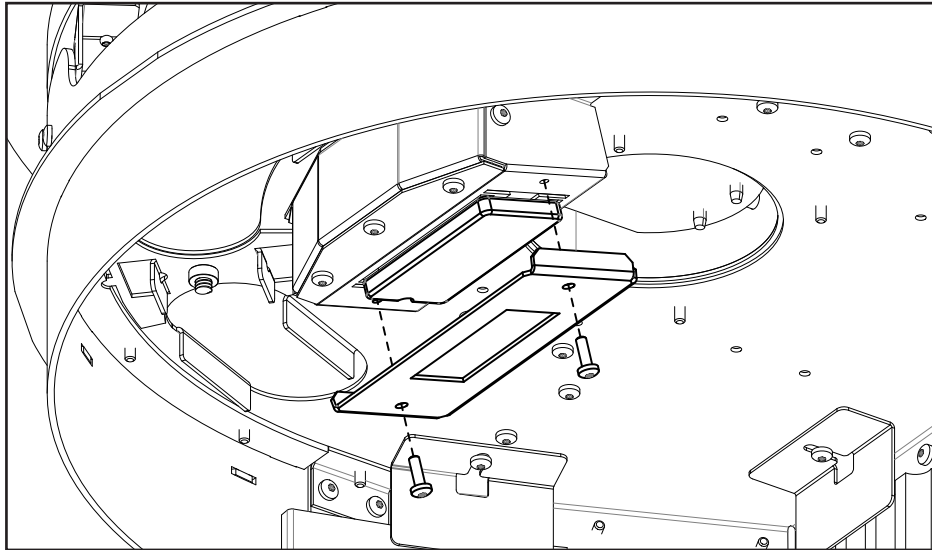

Figure 33: Top Light Removal

OPTIONAL FAN REPLACEMENT (50-4247)

The S50 has an optional fan kit that can be added to the unit (50-4247). Disconnect power cord proceeding. To replace the fan, first remove the door frame and skirt (refer to page 17 and 16 for details). On the left side of the unit there is a cavity that allows access to the fan (see Figure 34). Remove the fan retainer screw (see Figure 35) and remove retainer. Shimmy the fan loose and work it out of the fireplace, disconnect the electrical wires once you're able to (see Figure 36).

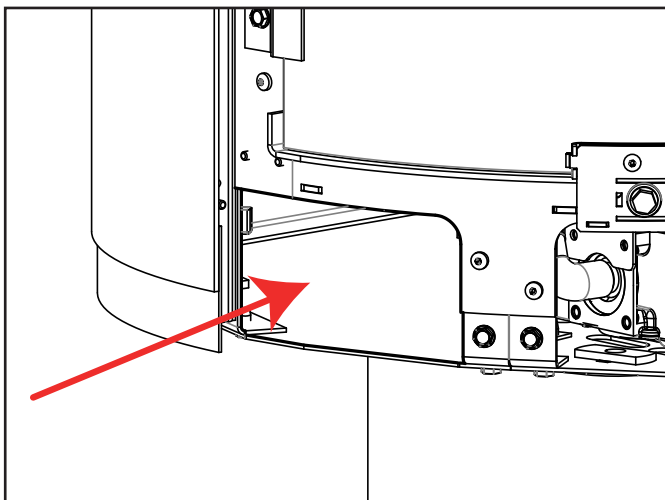

Figure 34: Fan Access Cavity

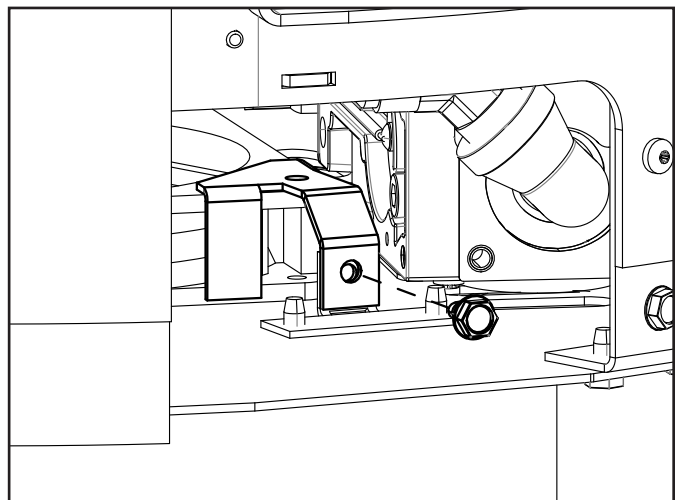

Figure 35: Fan Retainer Detachment

MAINTENANCE AND SERVICE

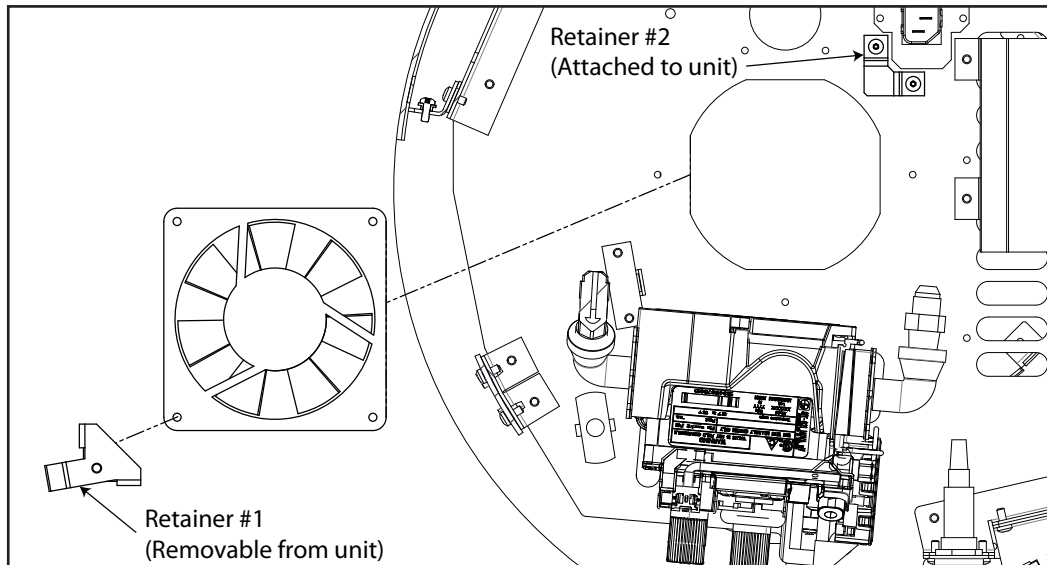

Figure 36: Fan Removal (Top-Down View)

When replacing the fan, ensure the label-side is facing down and electrical contacts are positioned at the same corner as retainer #1 (see Figure 27). Re-attach the electrical harness and work fan into position by wedging the respective corner into retainer #2 (see Figure 27). Try not sliding the fan on the foam gasket, it's for compression only. Once in place, position retainer #1 back over the respective corner and hold in place while reattaching retainer screw; the fan should now feel secure. Reconnect power and test fan.

REPLACING TRIM PARTS

All powder coated trim pieces on the S50 can be removed and replaced if damaged. This section will go over how to remove these pieces from the unit to then be replaced.

DOOR HOOKS

First, remove the door frame from the unit (refer to the REMOVING THE DOOR FRAME/SKIRT section on page 17).

The door frame hooks are each attached to five (5) studs on the main door frame. Remove the nuts retaining the hooks and remove from the door frame (refer to Figure 37).

FRONT SKIRT

First, remove the door frame from the unit (refer to the REMOVING THE DOOR FRAME/SKIRT section on page 17).

The front skirt is hooked onto the rear chassis using two hooks on each side of the skirt. Simply lift the skirt up and away from the unit.

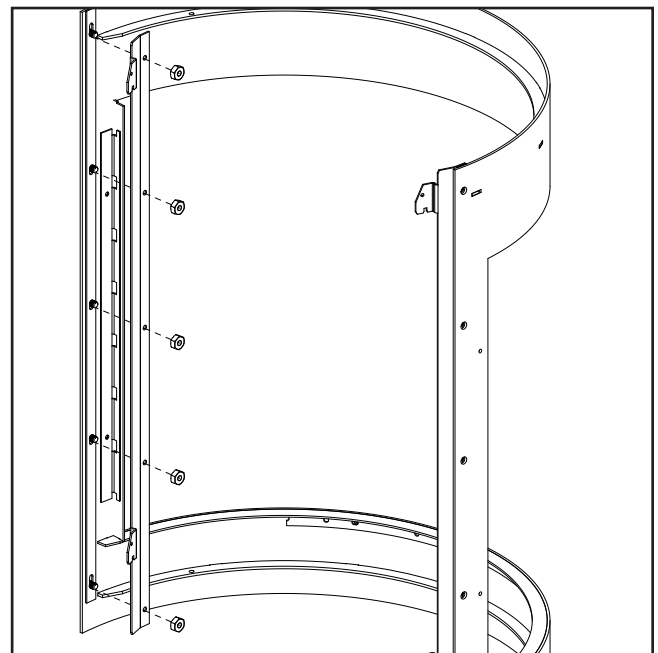

Figure 37: Door Frame Hook Removal

MAINTENANCE AND SERVICE

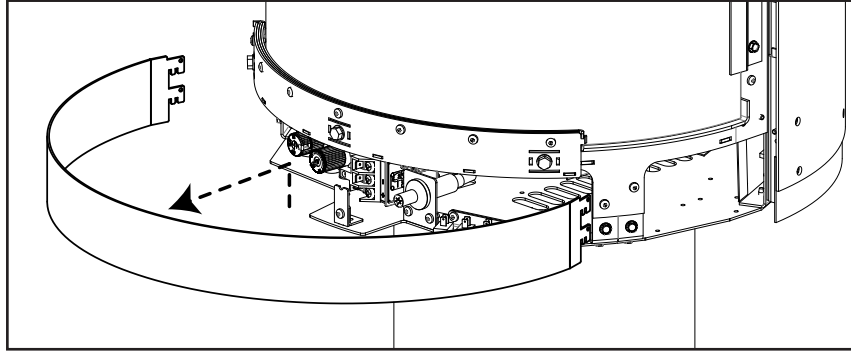

Figure 38: Front Skirt Removal

REAR SKIRT

Remove the door frame from the unit (refer to the REMOVING THE DOOR FRAME/SKIRT section on page 17).
Next, remove the rear chassis from the unit (refer to the REMOVING THE REAR CHASSIS section of page 19).

Remove the four (4) nuts retaining the rear skirt using a 3/32" (or 9mm) socket (see Figure 39).

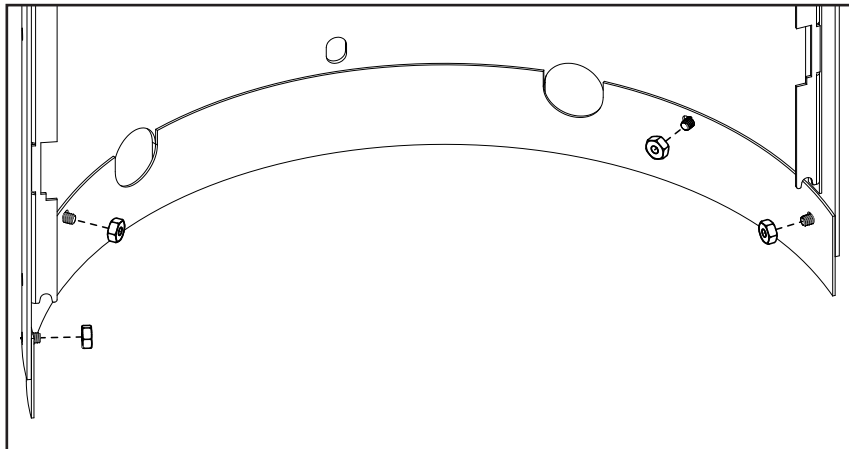

Figure 39: Rear Skirt Removal

MAINTENANCE AND SERVICE

REMOVING TOP PLATE

TOP PLATE FASCIA BAND

First, remove the top plate from the unit (refer to the REMOVING THE TOP PLATE section on page 21).

Remove the four (4) T20 screws. Twist the Fascia Band assembly and lift the fascia band up to remove it (see Figure 40).

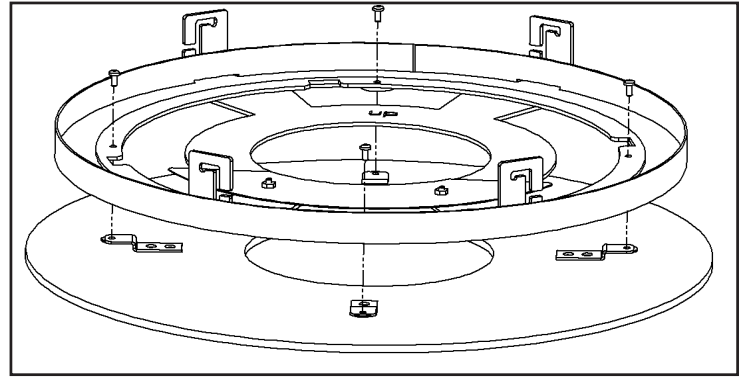

Figure 40: Top Plate Fascia Band Removal

To remove the top plate, first lift the plate half way (about 1/2" up) and rotate the top plate counter-clockwise. The slot mechanism should be disengaged and the top plate can be lifted up and removed from the unit.

***NOTE:** While lifting the top plate, keep it leveled will make the process easier. Also, the slot can be seen through fireplace front door.

Figure 41 shows the top plate moving pattern.

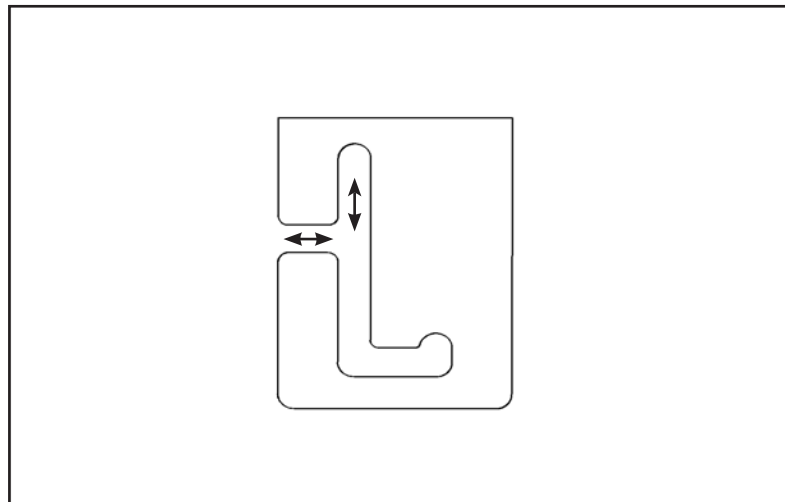

Figure 41: Top Plate Hinge Detachment

BURNER REMOVAL

The stainless steel burner pan will need to be checked seasonally for corrosion and foreign debris. Ensure no material is obstructing the segregated pilot area or air servicing channels as illustrated in Figure 99. Remove the burner for inspection.

To remove the burner, first remove the door frame and glass (refer to page 17 and page 18 for details). Remove the nine (9) screws securing the burner platform using a T20 screwdriver (see Figure 42).

Remove the pilot fence by hand taking care not to damage the ceramic fiber gasket (see Figure 43). This gasket is used to prevent drafts from interfering with the pilot flame so replace if damaged.

Remove the four (4) screws securing the burner pan using a T20 screwdriver. Rotate the burner upward and lift out (see Figure 44).

MAINTENANCE AND SERVICE

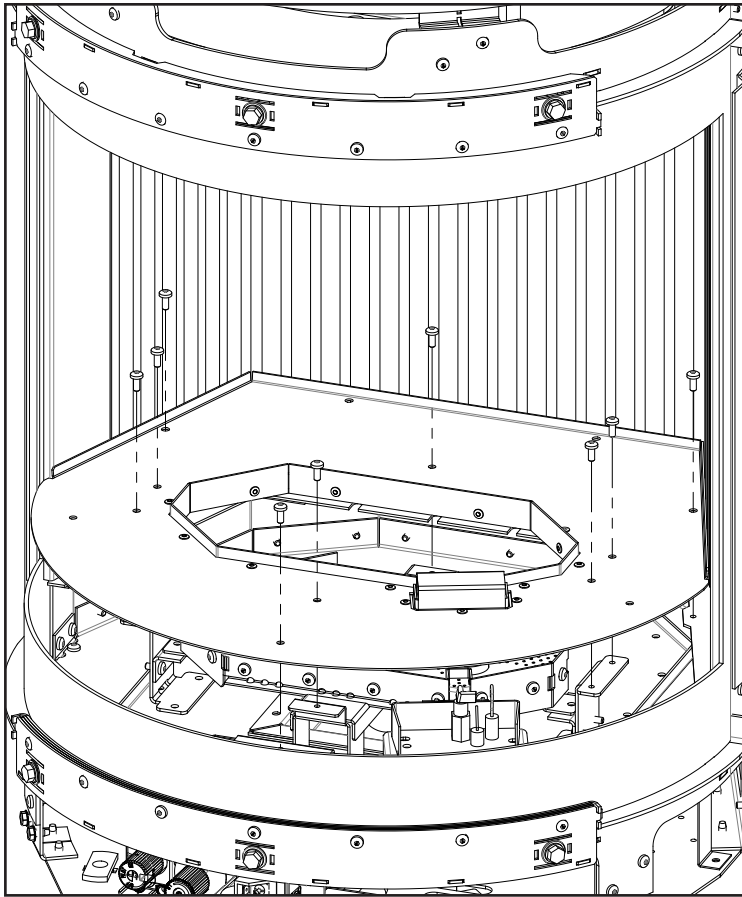

Figure 42: Burner Platform Removal

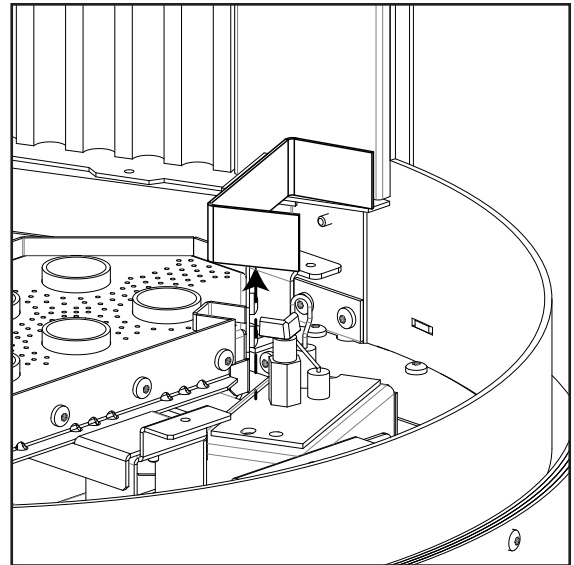

Figure 43: Pilot Fence Removal

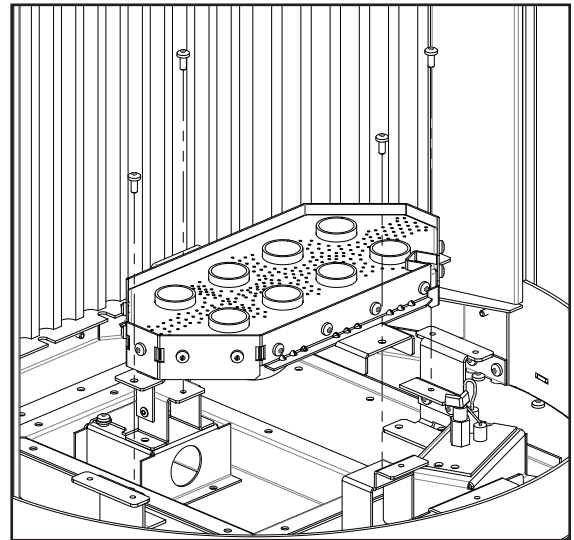

Figure 44: Burner Removal

FUEL CONVERSION

TO BE INSTALLED BY A QUALIFIED SERVICE AGENCY ONLY

Please read and understand these instructions before installing.

Warning: This conversion kit shall be installed by a qualified service agency in accordance with the manufacturer's instructions and all applicable codes and requirements of the authority having jurisdiction. If the information in these instructions is not followed exactly, a fire, explosion or production of carbon monoxide may result causing property damage, personal injury or loss of life. The qualified service agency is responsible for the proper installation of this kit. The installation is not proper or complete until the operation of the converted appliance is checked as specified in the manufacturer's instructions supplied with the kit.

MAINTENANCE AND SERVICE

Kit Parts List for all S50I models:

- | | |
|---|------------------------------------|
| 1 - Orifice (NG: #37) or (LP: #53) | 1 - Conversion label |
| 1 - Pilot Orifice (LP orifice supplied with unit) | 1 - Installation instruction sheet |
| 1 - Servo Regulator with Diaphragm | |

Carefully inspect all parts supplied with this conversion kit. If any parts have been damaged or are missing, contact your dealer, distributor or courier company to have them replaced before starting this installation.

Conversion Kit Installation:

1. Turn control knob on the gas valve to the "OFF" position and shut the gas supply off at the shut-off valve upstream of the unit. **CAUTION:** The gas supply must be shut off prior to disconnecting the electrical power and before proceeding with the conversion. Allow the valve and unit to cool down to room temperature.
2. Remove the door frame and glass as shown in their respective sections on page 17 and page 18.
3. Carefully remove the log set.
4. Remove the burner as shown in the BURNER REMOVAL section on page 23.
5. Convert the pilot orifice:
 - a) Using a $\frac{7}{16}$ " wrench, loosen the pilot head counter clockwise and remove
 - b) Remove the existing orifice and replace with the one supplied in the kit (Figure 45)
 - c) Re-install the pilot head and tighten until it is back in the proper position (Figure 46)
6. Convert the burner orifice:
 - a) Remove the main burner orifices with a $\frac{1}{2}$ " deep socket
 - b) Put a bead of pipe-thread sealant into the orifice mount. **DO NOT OVERTIGHTEN**
 - c) Install the new orifice.
7. Convert the SIT gas valve:
 - a) Use a T-20 driver to remove the two screws that hold the servo regulator to the gas valve and disconnect the wire harness from the IFC.
 - b) Remove the rubber regulator diaphragm that is situated between the servo regulator and the valve body. The new servo regulator already has this diaphragm installed.
 - c) Install the LP servo regulator, with the new longer T-20 screws included in the kit and connect the harness to the IFC.
8. Reinstall the burner, burner platform, log set, glass, and door frame. Also refer to the LOG SET INSTALLATION section on page 52.
9. Reconnect the main gas line if it was disconnected and open the shut-off valve at the gas line to the unit.
10. Reconnect the electrical power to the unit.
11. Use a small brush to apply a warm soapy water solution to all gas connections (use a half dish soap and half warm water). If a gas leak is present, bubbling will occur. Gas leaks can be repaired by using an approved pipe thread sealant or approved Teflon tape. **NEVER USE AN OPEN FLAME WHEN TESTING FOR LEAKS.**



Figure 45: Pilot Orifice



Figure 46: Proper Pilot Position

MAINTENANCE AND SERVICE

12. Relight the pilot and confirm the flame properly covers both the thermocouple and thermopile. Should the pilot require adjustment, turn the adjustment screw clockwise to decrease or counterclockwise to increase until the correct flame is achieved.
13. Relight the main burner in both the "HI" and "LO" positions to verify proper burner ignition, operation and proper flame appearance (page 38). Confirm the inlet and manifold pressures are within the acceptable ranges as directed in the GAS LINE CONNECTION section on page 41. **If the S50I has been installed at an altitude higher than 2000ft (610m) it is required to de-rate the unit accordingly:**

In the USA: The appliance may be installed at higher altitudes. Please refer to your American Gas Association guidelines which state: the sea level rated input of Gas Designed Appliances installed at elevations above 2000 (610 m) feet is to be reduced 4% for each 1000 feet (305 m) above sea level. Refer also to local authorities or codes which have jurisdiction in your area regarding the de-rate guidelines.

In Canada: When the appliance is installed at elevations above 4500 feet (1372 m), the certified high altitude rating shall be reduced at the rate of 4% for each additional 1000 feet (305 m).
14. MAKE SURE that the conversion label is installed on or close to the rating label to signify that the unit has been converted to a different fuel type.

INITIAL INSTALLATION

QUALIFIED INSTALLERS ONLY

INTRODUCTION

This section of the owner's manual is for the use of qualified technicians only. Fireplace placement, hearths, and venting terminations will be covered, as well as the gas and electrical systems. There are several installation safety guidelines that must be adhered to. Please carefully read the safety precautions at the front of this manual.

PREPARATION FOR INSTALLATION

- Remove the packaging from the appliance and check to make sure there is no damage. If damage is found, please report it to both the carrier and your dealer as soon as possible. Take care not to strike the finish when unpacking the S50. Damage created by a utility knife (or the like) during unpacking will not be covered under warranty.
- Before beginning, carefully check the glass door and log set.
- Locate a position where the flue system of the stove can be properly installed without damaging the integrity of the building; e.g. cutting a wall or ceiling joist.
- Check store and flue system clearance requirements.
- Locate the stove where it can be accessed by a gas supply line

INITIAL INSTALLATION

QUALIFIED INSTALLERS ONLY

CLEARANCE TO COMBUSTIBLES

Warning: Clearances must be sufficient to allow for maintenance and service.

A. Side Wall to Edge of unit:	12" [30.5 cm]
B. Side Wall to Center of unit:	22" [55.9 cm]
C. Back Wall to Edge of unit:	3" [7.6 cm]
D. Back Wall to Center of unit:	13" [33.0 cm]
E. Ceiling to unit:	16" [40.6 cm]
F. Floor (hard wood & linoleum)	0" [0 cm]

***Note:** When installing on a carpeted surface, a hearth pad must be used (not supplied) for air flow reasons.

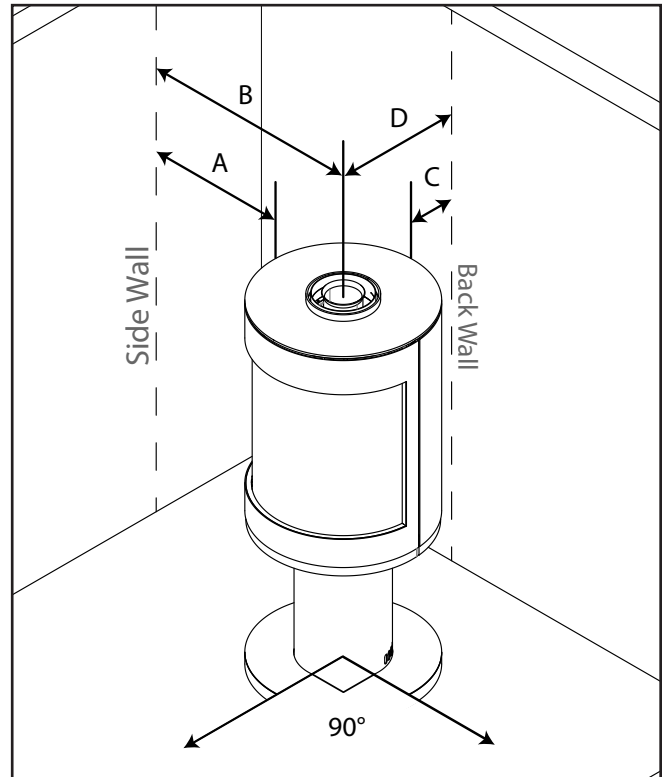

Figure 47: Clearance to Combustibles

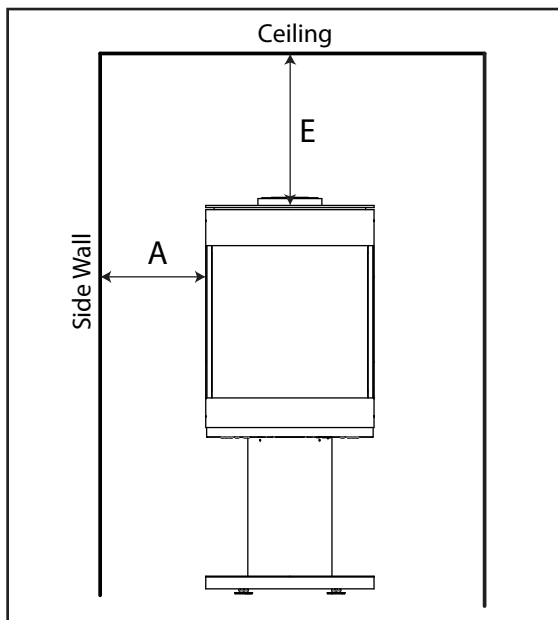

Figure 48: Clearance to Combustibles - Ceiling

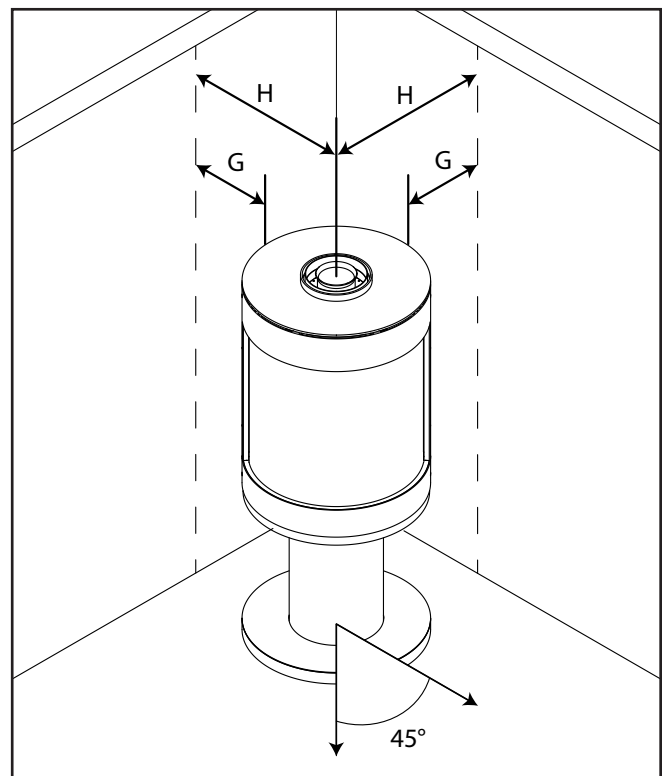

Figure 49: Clearance to Combustibles - Corner Install

MINIMUM DIMENSIONS - CORNER INSTALL

Warning: Clearances must be sufficient to allow for maintenance and service.

G. Wall to Edge of unit:	6" [15.2 cm]
H. Wall to Center of unit:	16" [40.6 cm]

MINIMUM ALCOVE DIMENSIONS:

Width	48" [121.9 cm]
Height	63" [160.0 cm]
Depth (Max.)	43" [109.2 cm]

INITIAL INSTALLATION

QUALIFIED INSTALLERS ONLY

DIRECT VENT

WARNING: This appliance has been designed to draw room air for proper heat circulation from the bottom of the unit, and out the top front. Blocking or modifying these openings in any way can create hazardous situations.

The vent length for the S50 must be between 21" (53.3 cm) and 40 ft (12.2 m). This model is vented with co-axial 4" intake, 6 5/8" exhaust aluminum or stainless steel approved rigid vent leading into a vertical or horizontal termination cap. The flue collar of this model will fit inside of a standard 4" x 6 5/8" vent and must be either correctly interlocked or fastened, with three screws directly to the vent.

Check periodically that the vents are unrestricted. Also ensure that all direct vent pipes have been properly sealed and installed after routine inspection or cleaning. The air intake and exhaust pipes must be installed in the correct location on top of the S50.

VENTING CLEARANCES

A 1" (25 mm) clearance to combustibles must be maintained around any vertical vent pipe. Around a horizontal vent pipe, the clearance to combustibles should be 2" (51 mm) above and 1 1/2" (38 mm) on the sides and bottom. When combustible materials are directly above a 90° elbow, 3" (76 mm) of clearance are necessary.

Table 2: Vent Pipe Minimum Clearances.

	Vertical Pipe to the Side Walls	Horizontal Pipe to the Sides & Bottom	Above an Elbow Above the Unit	Above an Elbow Not Above the Unit	Above Horizontal Vent Pipe	Wall Frame 8" (203mm) or less
Hard Pipe	1" (25.4 mm)	1 1/2" (38.1 mm)	3" (76.2 mm)	3" (76.2 mm)	2" (51 mm)	10"x10" (25x25cm)

A 10" (254 mm) x 10" (254 mm) frame (see Figure 50) will assure the proper support and spacing for the vent pipe as it passes through the wall. Installations in Canada require that a wall thimble be used for passing through walls and ceilings. All sealing and vapour barriers must comply with local building codes.

The configuration of the venting pipes depends on the locations of walls, ceilings, and studs. However, the pipes cannot be of arbitrary length and arrangement. Because the length of the vertical and horizontal sections dramatically affects the burning efficiency of the fireplace, certain guidelines have been set in the vent configuration sections starting on page 32. Venting terminals can not be recessed into a wall or siding.

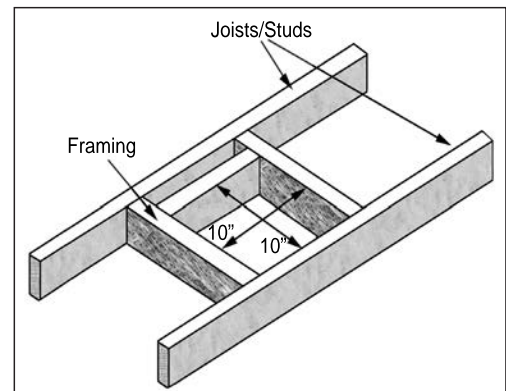

Figure 50: Vent Framing For Wall or Ceiling.

WARNING: This gas appliance must not be connected to a chimney flue serving a separate solid-burning appliances.

APPROVED VENTING PARTS

The S50I fireplace has been tested and certified for use with the venting systems shown in Table 3 & Table 4. Refer to the table below for part numbers of commonly used parts for both venting systems. For more venting parts please visit the respective manufacturers' website.

Table 3: Approved Vent Manufacturers

Manufacturer	Trade Name	Nominal Sizes
ICC	EXCELDirect	4" x 6 5/8"
M&G DuraVent	DirectVent Pro	
Selkirk	Direct-Temp	
Amerivent	Direct Vent	

INITIAL INSTALLATION

QUALIFIED INSTALLERS ONLY

WARNING: Do not mix parts from different vent manufacturers' systems.

EXCEPTION TO WARNING: This product has been evaluated by Intertek for using a DirectVent Pro starting collar in conjunction with other venting systems. Use of this system with the DirectVent Pro starting collar is deemed acceptable and does not affect the Intertek listing of the appliance.

Table 4: Vent part numbers (Must state if galvanized or black wanted, PART NUMBERS).

Direct Vent	Direct-Temp	DirectVent Pro	EXCELDirect	Description
4D7 (7")	4DT-06	46DVA-06	DL6	6" Pipe Length
 	4DT-09	46DVA-09	DL9	9" Pipe Length
4D2	4DT-12	46DVA-12	DL1	12" Pipe Length
 	4DT-18	46DVA-18	 	18" Pipe Length
 	4DT-24	46DVA-24	DL2	24" Pipe Length
4D3	4DT-36	46DVA-36	DL3	36" Pipe Length
4D4	4DT-48	46DVA-48	DL4	48" Pipe Length
 	 	46DVA-60	 	60" Pipe Length
4D26A	4DT-TL14	46DVA-24TA	DLA30	Adjustable Length
4D45L	4DT-EL45	46DVA-E45	4DE45	45° elbow
4D90L	4DT-EL90S	46DVA-E90	4DE90	90° elbow
4DHVS	4DT-VS	46DVA-VSS	VSS	Vinyl siding standoff/sheild
4DWT	4DT-WT	46DVA-WT	4WT	Wall thimble
4DSC	4DT-SC	46DVA-SC	SC	Storm collar
4DFSP	4DT-FS	46DVA-WFS	4CS	Fire stop
4DWS	4DT-WS	46DVA-WS	WS	Wall strap/ support/band
4DF	4DT-AF6	46DVA-F6	4FA	Flashing, standard roof pitch
4DF12	4DT-AF12	46DVA-F7	4FB	Flashing, steep (up to 12/12) roof
 	 	46DVA-FF	4F	Flat flashing
 	 	46DVA-VCH	SVT	High wind vertical termination
4DHCS	4DT-HC	46DVA-HC	HT	High wind horizontal termination
 	4DT-HKA / 4DT-HKB	46DVA-KHC	4HTK	Horizontal
 	4DT-CCKA	46DVA-KCA	4CA6	Chimney
4DRCKA	4DT-CCKB	46DVA-KCB	4CA7	Chimney
 	 	46DVA-KCC	4CA8	Chimney
 	4DT-ST14	46DVA-SNK14	ST14	14" Snorkel
 	4DT-ST36	46DVA-SNK36	ST36	36" Snorkel

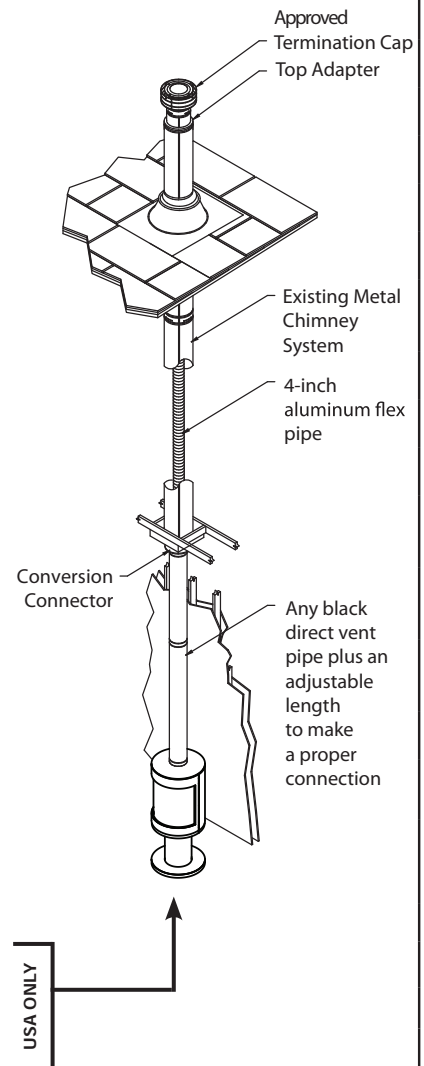

INITIAL INSTALLATION

QUALIFIED INSTALLERS ONLY

VENT TERMINATION RESTRICTIONS

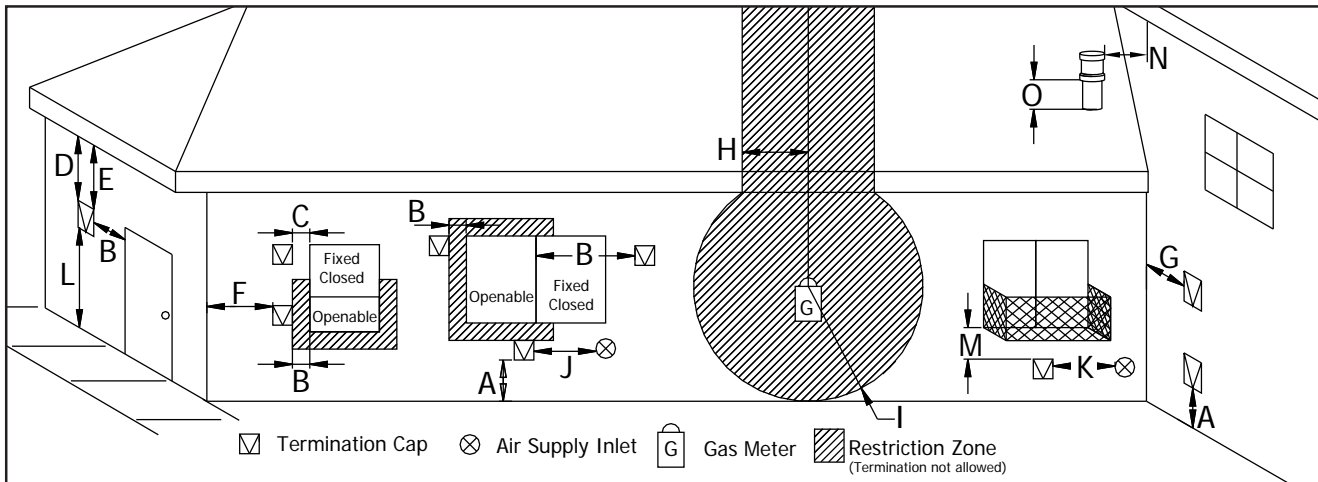

Figure 51: Vent Termination Restrictions, refer to Table 5.

Table 5: Vent termination clearances.

Letter	Canadian Installation ¹	US Installation ²	Description
A	12 in (30 cm)		Clearance above grade, verandah, porch, deck, or balcony.
B	12 in (30 cm)	9 in (23 cm)	Clearance from window or door that may be opened.
C	12 in (30 cm)*		Clearance from permanently closed window (to prevent condensation).
D	18 in (45.7 cm)*		Vertical clearance to ventilated soffit located above the terminal, within a horizontal distance of 2 ft (60 cm) from center line of terminal.
E	18 in (45.7 cm)		Clearance to unventilated soffit.
F	12 in (30 cm)*		Clearance to outside corner.
G	12 in (30 cm)		Clearance to inside corner.
H	3 ft (91 cm) within a height of 15 ft (4.5 m) above the meter/regulator assembly	3 ft (91 cm) within a height of 15 ft (4.5 m) above the meter/regulator assembly*	Clearance to each side of center line extended above meter/regulator assembly.
I	3 ft (91 cm)	3 ft (91 cm)*	Radial clearance around service regulator vent outlet.
J	12 in (30 cm)	9 in (23 cm)	Clearance to non-mechanical air supply inlet to building, or the combustion air inlet to any other appliance.
K	6 ft (1.83 m)	3 ft (91 cm) above if within 10 ft (3 m) horizontally	Clearance to mechanical air supply inlet.
L	7 ft (2.13 m) ^t	7 ft (2.13 m) ^{*t}	Clearance above paved sidewalk or paved driveway located on public property.
M	14 in / 35.5 cm ⁺	14 in / 35.5 cm ⁺	Clearance under verandah, porch, deck, or balcony.
N	12 in (30 cm)*		Clearance horizontally to any surface (such as an exterior wall) for vertical terminations.
O	12 in (30 cm)		Clearance above roof line for vertical terminations.

¹ In accordance with the current CSA B149, Natural Gas and Propane Installation Code.

² In accordance with the current ANSI Z223.1 NFPA 54, National Fuel Gas Code.

* These numbers are only estimates.

^t A vent shall not terminate directly above a side walk or paved driveway that is located between two single family dwellings and it serves both dwellings.

⁺ Permitted only if verandah, porch, deck, or balcony is fully open on a minimum of two sides beneath the floor.

Clearances are in accordance with local installation codes and the requirements of the gas supplier.

NOTE: Venting terminals shall not be recessed into walls or siding.

INITIAL INSTALLATION

QUALIFIED INSTALLERS ONLY

EXHAUST RESTRICTOR SETTINGS

The S50 has an internal exhaust restrictor that can be adjusted externally. Depending on the venting configuration this may need to be adjusted. The restrictor dial is accessed from the top of the fireplace, below the top plate (refer to the section "Lifting the Top Plate" on page 15 for instructions). Using a 7/16" socket, rotate the restrictor CLOCKWISE until the desired setting is in-line with the finger catch. The proper setting is crucial for an efficient burn and best flame appearance.

It may be necessary to deviate from the recommended setting as different altitudes and climates can vary the operation of the fireplace. With propane (LP) fueled fireplaces, it is always a good idea to offer slightly less restriction for higher altitudes to reduce the potential of sooting over an extended period.

*Note: The restrictor is set in the fully open position from the factory.

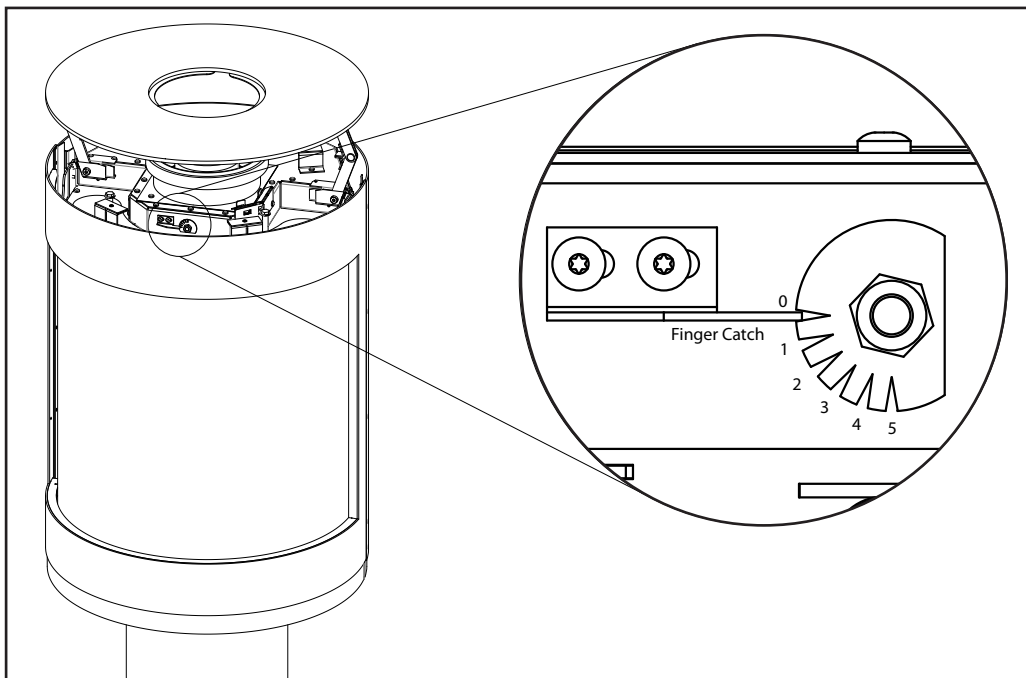

Figure 52: Exhaust Restrictor

INITIAL INSTALLATION

QUALIFIED INSTALLERS ONLY

MINIMUM TOP VENT CONFIGURATIONS

Refer to Table 6 and Figure 53 below for the minimum allowable top venting setup for the S50.

Table 6: Minimum Top Vent Configurations

	"A" [Vertical Rise]	"B" [Horizontal Run]	Termination Type
NG	12" [Min.]	12" Max Out	Straight Termination
		48" Max Out	36" Snorkel
	18"	18" Max Out	Straight Termination
	24"	48" Max Out	Straight Termination
LP	24" [Min.]	18" Max Out	Straight Termination
		24" Max Out	14" Snorkel
		48" Max Out	36" Snorkel

*Note: When installing above minimum allowable venting any horizontal termination listed in Table 4 on page 29 is permitted for use.

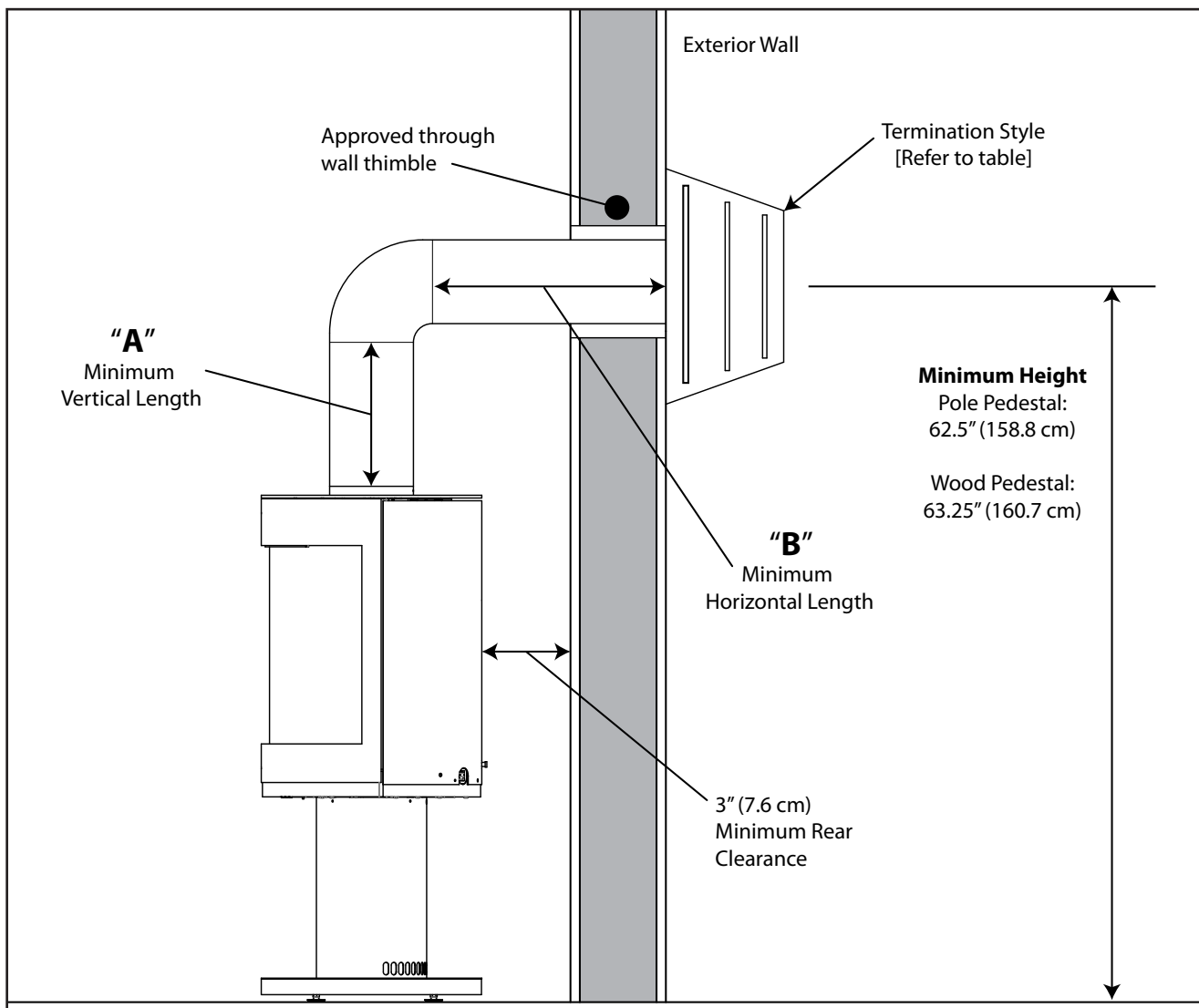

Figure 53: Minimum Vent Configuration - Top Vent

INITIAL INSTALLATION

QUALIFIED INSTALLERS ONLY

TOP VENT CONFIGURATION - NATURAL GAS (NG)

NG Top Vent Configurations

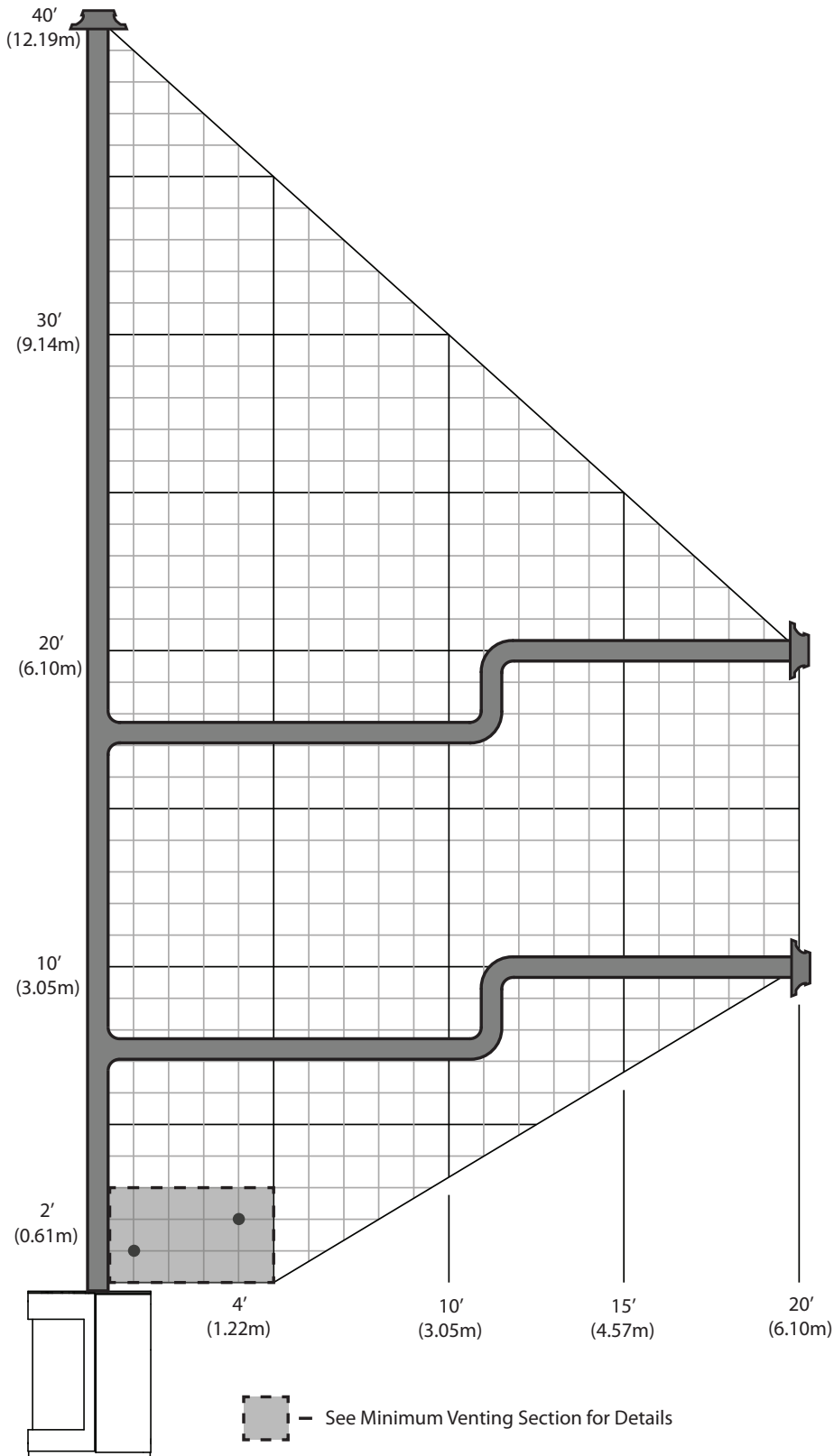

The following charts show the range of venting options available for top vent configurations using either vertical or horizontal terminations in conjunction with 0 - 3 90° elbows in the vertical plane. Having the fewest number of elbows is ideal as they restrict air flow. The total length of horizontal vent pipe can not exceed 20ft (6.1m) and the total vertical length can not exceed 40ft (12.2m). Any combination of rise and run can be used as long as it lays within the shaded areas of the following charts. A total of three (3) 90° elbows or six (6) 45° elbows can be used as shown in Figure 54 & Figure 55. In addition to what is shown, if a 90° elbow is used in the horizontal plane, 3 ft (91.4cm) must be subtracted from the allowable horizontal run (for each 45° elbow, 1.5ft (45.7cm) must be subtracted).

Figure 54: Top Vent Configuration Diagram - NG

INITIAL INSTALLATION

QUALIFIED INSTALLERS ONLY

TOP VENT CONFIGURATION - PROPANE (LP)

LP Top Vent Configurations

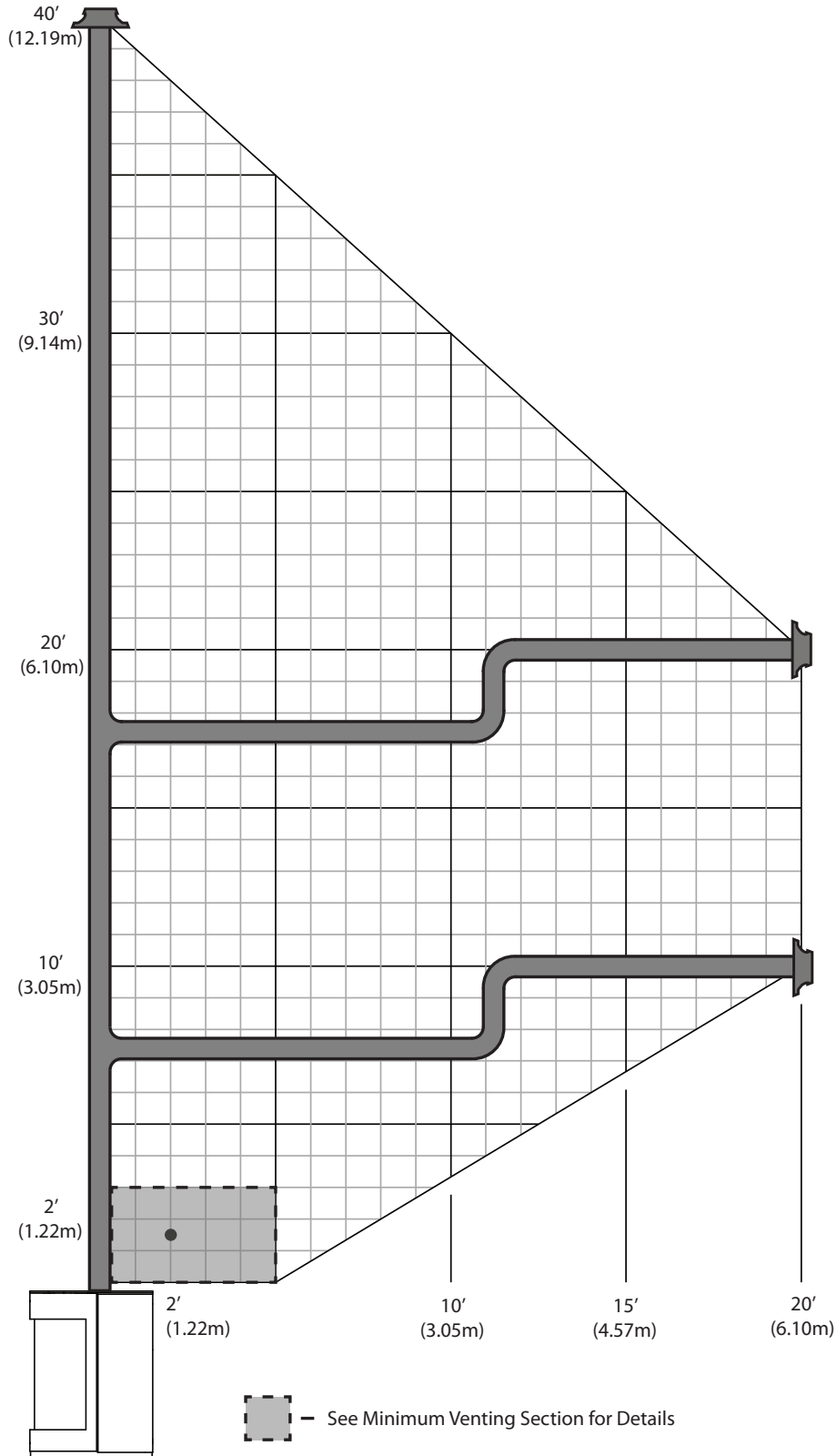

Figure 55: Top Vent Configuration Diagram - LP

INITIAL INSTALLATION

QUALIFIED INSTALLERS ONLY

MINIMUM REAR VENT CONFIGURATIONS

Refer to Table 7 and Figure 56 below for the minimum allowable rear venting setup for the S50.

Table 7: Minimum Rear Vent Configurations

	"A" [Horizontal Run]	Termination Type
NG	18" [Max]	14" Snorkel
	up to 36"	36" Snorkel
LP	9" [Min.] - 18" [Max]	36" Snorkel

***Note:** ALL rear vent configurations require a snorkel style termination.

***Note:** When performing an **LP Rear Vent Corner Install with 45° Elbow**, a **DURAVENT 36" SNORKEL MUST BE USED**. The 45° elbow accounts for 6" of vent run.

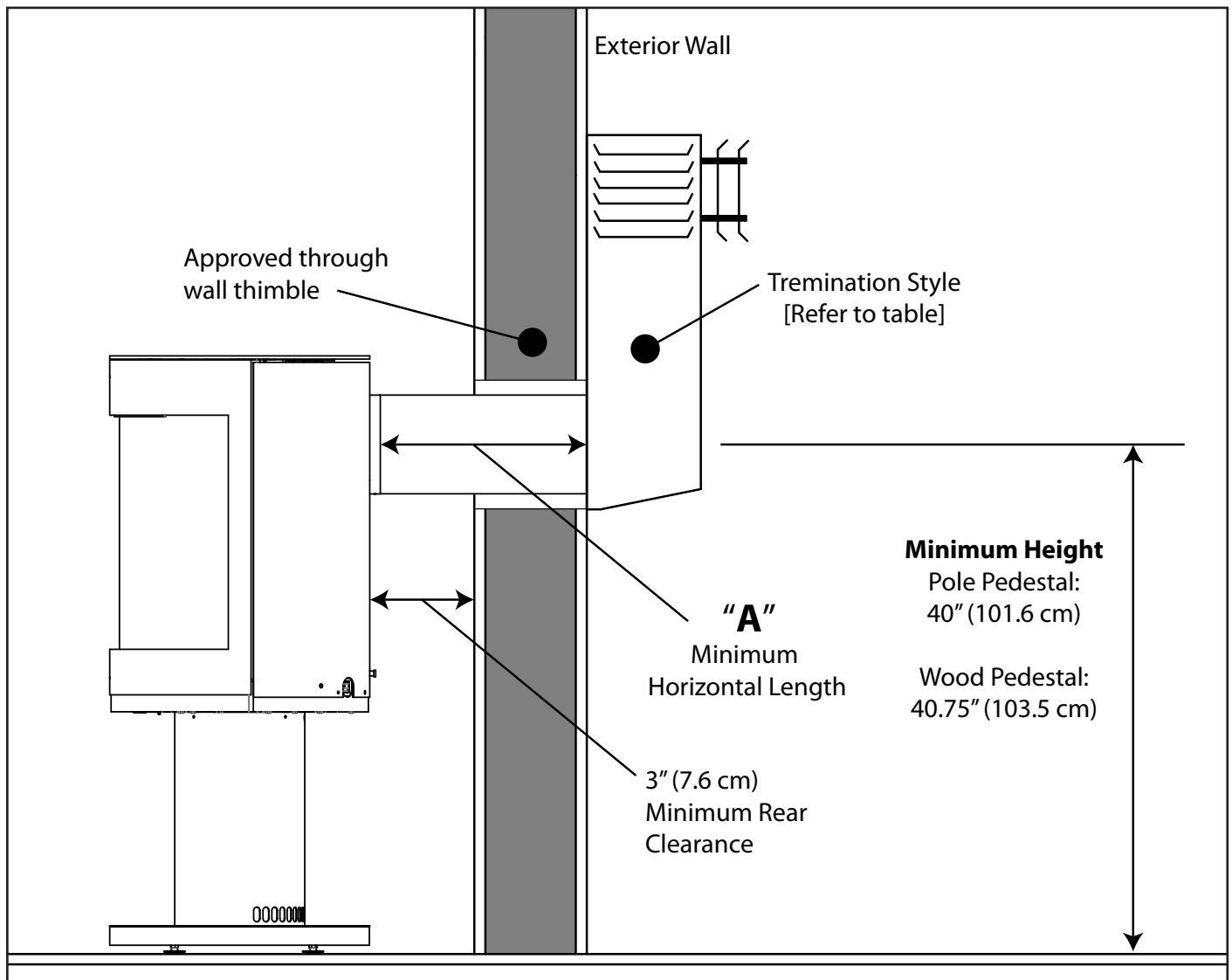

Figure 56: Minimum Vent Configuration - Rear Vent

INITIAL INSTALLATION

QUALIFIED INSTALLERS ONLY

REAR VENT - CORNER INSTALLATION

ATTENTION

When performing an **LP Rear Vent Corner Install with 45° Elbow, a DURAVENT 36" SNORKEL MUST BE USED.** No other brand venting can be used for LP corner installations.

Rear vent corner installs have the same vent run restrictions as a typical rear vent installations. Refer to Table 7 in the previous section for details.

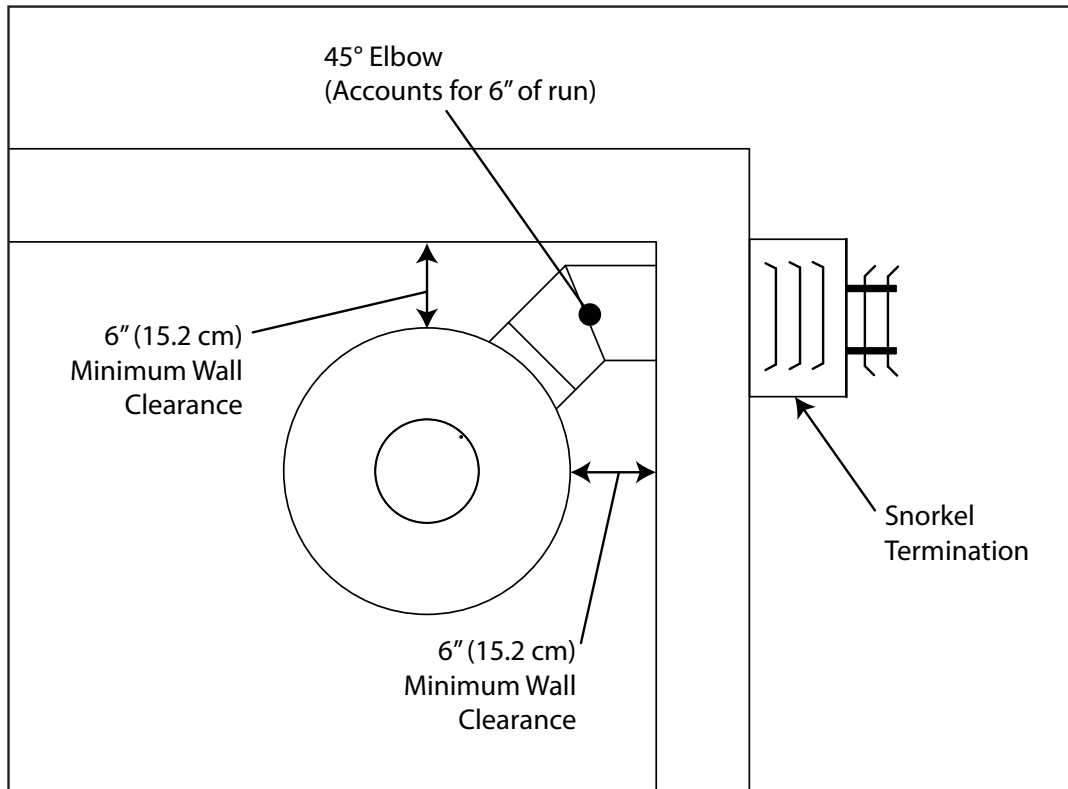

Figure 57: Rear Vent Corner Install Venting - Top View

INITIAL INSTALLATION

HORIZONTAL TERMINATION QUALIFIED INSTALLERS ONLY

NOTES:

- 1. Horizontal pipes must not be level. For every 12 inches (305 mm) of horizontal travel (away from the stove), there should be at least ¼ inch (6.4 mm) of vertical travel. Never allow the vent to run downward, as this could cause high temperatures or even present the possibility of a fire.**
- The exterior of the horizontal vent termination must not be blocked or obstructed.
- If the vent termination is not being attached to wood, the four wood screws provided should be replaced with material appropriate fasteners.
- For buildings with vinyl siding, a vinyl standoff should be installed between the vent cap and the exterior wall. Attach the vinyl standoff to the horizontal termination. Note that the termination bolts onto the flat portion of the standoff, providing an air space between the wall and the vent termination. The air gap prevents excessive heat from possibly melting the vinyl siding.
- Horizontal pipes must be supported every 3 feet (914 mm). Plumber's all round strap will suffice.

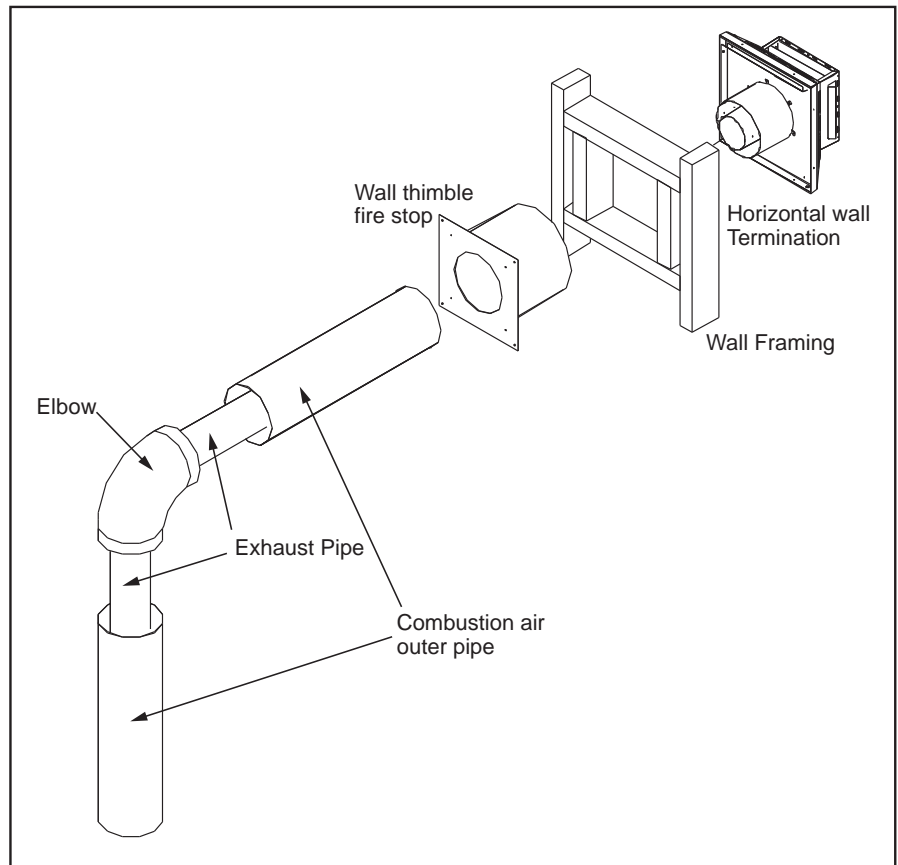

Figure 58: Horizontal Vent Termination

- When running horizontal pipe, clearances to combustibles must be maintained 1½ inches (38 mm) sides, 1½ inches (38 mm) bottom, and 2 inches (51 mm) top.
- Step 1.** Set the fireplace in the desired location. Check to determine if wall studs will be in the way when the venting system is attached. If this is the case, the location of the fireplace may have to be adjusted or the venting may have to be offset.
- Step 2.** Direct vent pipe sections are designed with special twist-lock connections. Dry fit the desired combination of pipe and elbows to the appliance adaptor.
- Step 3.** With the pipe in the correct position and attached to the fireplace, mark the wall for a 10 inches (25.4 cm) x 10 inches (25.4 cm) square hole (see Figure 51). The center of the hole should match the center line of the horizontal pipe. Cut and frame the hole in the exterior wall where the vent will be terminated. If the wall being penetrated is made of a non-combustible material (i.e. masonry or concrete) a 7 inches (17.8 cm) hole is acceptable.

INITIAL INSTALLATION

QUALIFIED INSTALLERS ONLY

- Step 4.** With the hole now framed, the wall thimble installed, and the pipe extending into the wall, proceed to the outside. Attach the termination to the pipe using RTV and Mil-Pac or Rutland No 78 Stove and Gasket Cement to seal joints. The vent pipe must extend into the vent cap at least 1¼ inches (3.2 cm). Secure the connection between the vent cap and the pipe by attaching the two (2) sheet metal straps, which extend from the vent cap assembly to the outer wall of the vent pipe. Bend any remaining portion of the strap back towards the vent cap. Security Secure Vent uses a twist lock cap.
- Step 5.** Position the horizontal vent termination in the center of the 10 inches (25.4 cm) square hole and attach to the exterior wall with the four screws provided. The arrow on the vent termination should be pointing up. Run a bead of non-hardening mastic around the edges of the vent cap, to make a seal with the wall. Ensure the proper clearances to combustibles have been maintained.

VERTICAL TERMINATION

- Step 1.** Check the instructions for required clearances (air spaces) to combustibles when passing through ceilings, walls, roofs, enclosures, attic rafters, or other nearby combustible surfaces. Do not pack air spaces with insulation.
- Step 2.** Set the gas appliance in the desired location. Drop a plumb bob down from the ceiling to the position of the appliance flue exit, and mark the location where the vent will penetrate the ceiling. Drill a small hole at this point. Next, drop a plumb bob from the roof to the hole previously drilled in the ceiling, mark the spot where the vent will penetrate the roof. Determine if ceiling joists, roof rafters, or other framing will obstruct the venting system. You may wish to relocate the appliance, or to offset, to avoid cutting load bearing members.
- Step 3.** To install the Round Support Box/Wall Thimble in a flat ceiling, cut a 10 inch (25.4 cm) square hole in the ceiling, centered in the hole drilled in Step 2. Frame the hole as shown in Figure 50.

- Step 4.** Assemble the desired lengths of black pipe and elbows necessary to reach from the appliance adapter up through the Round Support Box. Insure that all pipe and elbow connections are in their fully twist-locked position.

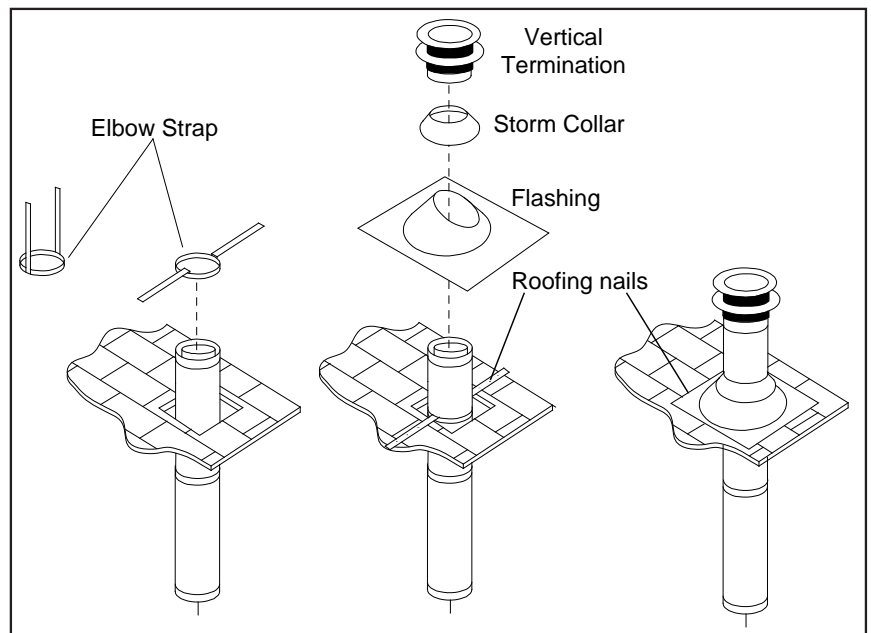

Figure 59: Vertical Vent Termination

INITIAL INSTALLATION

QUALIFIED INSTALLERS ONLY

- STEP 5.** Cut hole in the roof centered on the small hole placed in the roof from Step 2. The hole should be of sufficient size to meet minimum requirements for Clearance to Combustibles, as specified. Continue to assemble lengths of pipe and elbows necessary to reach from the ceiling support box up through the roof line. Galvanized pipe and elbows may be utilized in the attic, as well as above the roof line. The galvanized finish is desirable above the roof line, due to the higher corrosion resistance.
- STEP 6.** Once the pipe sections have been joined, and run up through the hole in the roof, slip an elbow strap over the exposed sections, bend the support straps outwards, and push the elbow strap down to the roof level, as shown in Figure 59. Tighten the clamp around the pipe section. Use a level to make sure the pipe is truly vertical. With roofing nails, secure the support straps to the roof. Seal the nails holes heads with non-hardening mastic. Trim the excess length of the support straps that extend out beyond the edge of the flashing.
- STEP 7.** Slip the flashing over the pipe section protruding through the roof. Secure the base of the flashing to the roof with roofing nails. Use a non-hardening sealant between the uphill edge of the flashing and the roof. Insure the roofing material overlaps the top edge of the flashing. Verify that you have at least the minimum clearance to combustibles at the roof line.
- STEP 8.** Continue to add pipe sections until the height of the vent cap meets the minimum code requirements. Refer to Figure 60 and Table 8. Note that for steep roof pitches, the vent height must be increased. In high wind conditions, nearby trees, adjoining roof lines, steep pitched roofs, and other similar factors can result in poor draft, or down drafting. In these cases, increasing the vent height may solve the problem.
- STEP 9.** Slip the storm collar over the pipe, and push it down to the top of the roof flashing as shown in Figure 59. Use the non-hardening sealant around the joint between the pipe and the storm collar.
- STEP 10.** Twist-lock the vent cap.

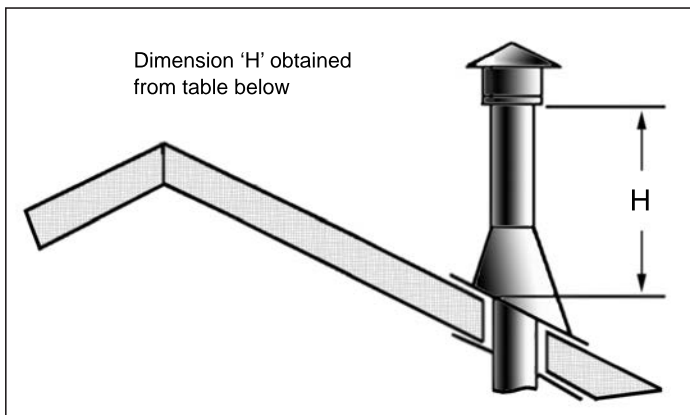

Figure 60: Height of Vertical Termination; Reference Table 8.

Table 8: Minimum 'H' for Figure 61.

Roof Pitch	Minimum Height (H)	
	Feet	Meters
Flat to 7/12	1	0.3
Over 7/12 to 8/12	1.5	0.46
Over 8/12 to 9/12	2	0.61
Over 9/12 to 10/12	2.5	0.76
Over 10/12 to 11/12	3.25	0.99
Over 11/12 to 12/12	4	1.22
Over 12/12 to 14/12	5	1.52
Over 14/12 to 16/12	6	1.83
Over 16/12 to 18/12	7	2.13
Over 18/12 to 20/12	7.5	2.29
Over 20/12 to 21/12	8	2.44

INITIAL INSTALLATION

QUALIFIED INSTALLERS ONLY

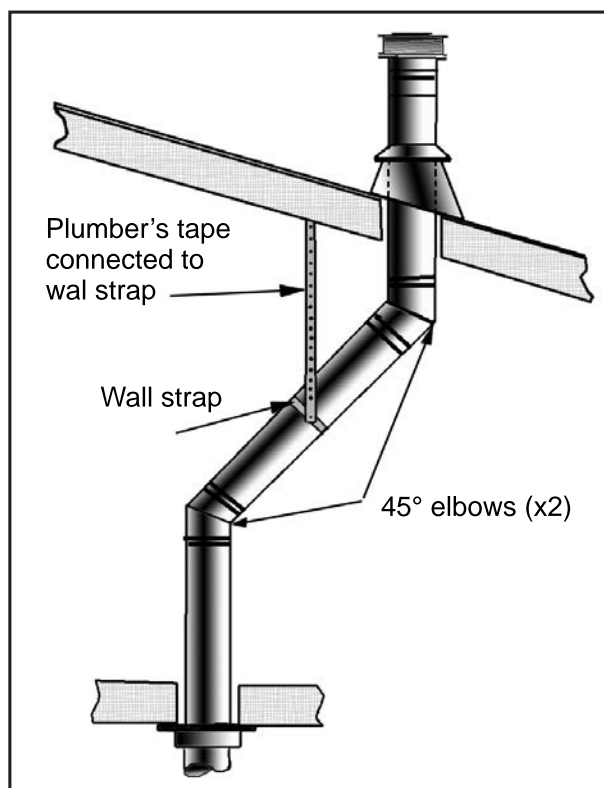

Figure 61: Use of Wall Straps.

NOTES:

- (1) If an offset is necessary in the attic to avoid obstructions, it is important to support the vent pipe every 3 feet (914 mm), to avoid excessive stress on the elbows, and possible separation. Wall straps are available for this purpose (see Figure 61).
- (2) When ever possible, use 45° degree elbows instead of 90° degree elbows. The 45° degree elbow offers less restriction to the flow of flue gases and intake air.
- (3) For multi story installations; a ceiling firestop is required at the second floor, and any subsequent floors (see Figure 62). The opening should be framed to 10" (254 mm) x 10" (254 mm) inside dimensions, in the same manner as shown in Figure 50.
- (4) Any occupied areas above the first floor, including closets and storage spaces, which the vertical vent passes through, must be enclosed. The enclosure may be framed and sheet-rocked with standard building materials. However consult the appliance manufactures installation instructions for the minimum allowable clearance between the outside of the vent pipe, and the combustibile surfaces of the enclosure. Do not fill any required air spaces with insulation.

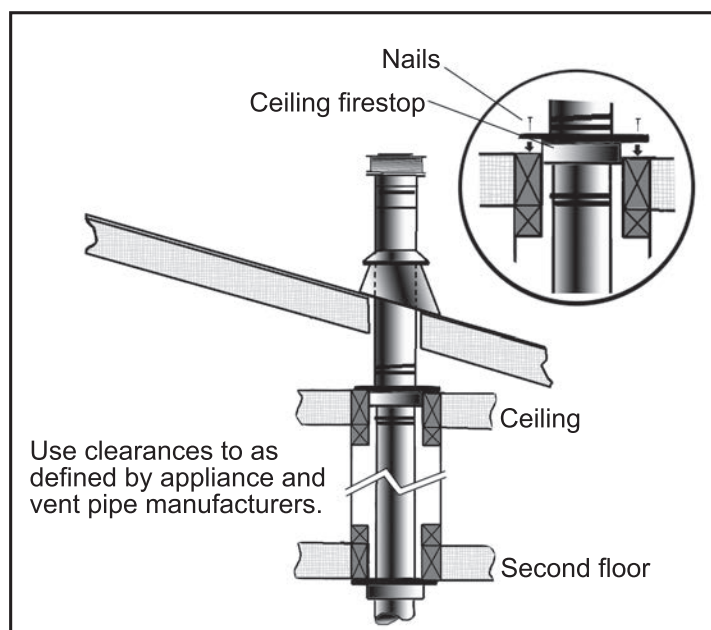

Figure 62: Multi-Story Vent Pipe Installation.

INITIAL INSTALLATION

QUALIFIED INSTALLERS ONLY

GAS LINE CONNECTION

WARNING: Only persons licensed to work with gas piping may make the necessary gas connections to this appliance.

GAS LINE CONNECTION

This stove is equipped with a certified flexible pipe located on the left side of the unit terminating in a 3/8" female NPT fitting. Consult your local authorities codes or the CAN/CGA B 149 (1 or 2) installation code in Canada, or in the USA gas installations follow either local codes or the current edition of the National Fuel Gas Code ANSI Z223.1.

The efficiency rating of this appliance is a product thermal efficiency rating determined under continuous operating conditions and was determined independently of any installed system.

The appliance and its shutoff valves must be disconnected from the gas supply piping system during any pressure testing where the pressure exceeds 1/2 PSIG (3.45 KPa) or damage will occur to the valve.

The appliance must be isolated from the gas supply piping system by closing its individual manual shutoff valve during any pressure testing of the gas supply piping system at test pressures equal to or less than 1/2 PSIG (3.45 KPa).

***Note: Always check for gas leaks with a soap and water solution after completing the required pressure test.**

The pressure taps are located on the left of the valve as shown in Figure 63.

- Turn the set screw 1 turn counter clockwise to loosen.
- Place 5/16" (8 mm) I.D. hose over pressure tap system.
- Check pressures using a manometer.
- When finished, release pressure, remove hose, and tighten set screw.

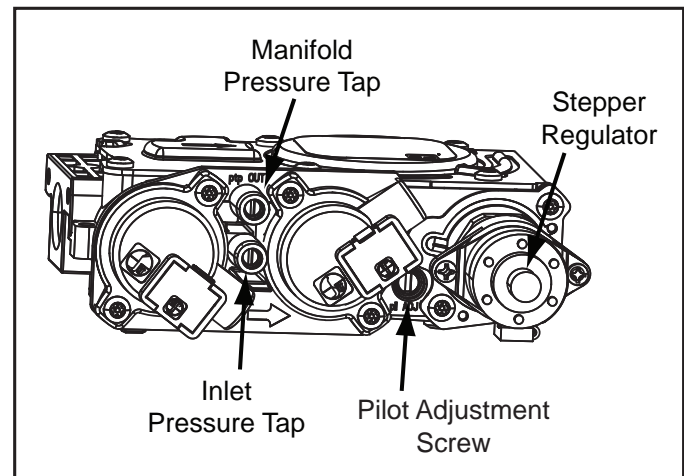

Figure 63: Fully Labeled Gas Valve

Table 9: Pressure and BTU Information

	Natural Gas [NG]	Propane [LP]
Main Orifice	#37	#53
Max Manifold Pressure	3.6 inch W.C. (0.89 kPa)	10 inch W.C. (2.49 kPa)
Min. Manifold Pressure	1.6 inch W.C. (0.39 kPa)	6.4 inch W.C. (1.59 kPa)
Max Supply Pressure	7 inch W.C. (1.74 kPa)	11 inch W.C. (2.74 kPa)
Min. Supply Pressure	4.5 inch W.C. (1.12 kPa)	10.4 inch W.C. (2.59 kPa)
Max BTU/hr Input	30,000 BTU/hr (8.79 kWh)	25,500 BTU/hr (7.47 kWh)
Min. BTU/hr Input	19,000 BTU/hr (5.57 kWh)	20,600 BTU/hr (6.04 kWh)

INITIAL INSTALLATION

QUALIFIED INSTALLERS ONLY

ELECTRICAL REQUIREMENTS

WARNING: This appliance is equipped with a three-prong (grounding) plug for your protection against shock hazard and should be plugged directly into a properly grounded three-prong receptacle. Do not cut or remove the grounding prong from this plug.

The appliance, when installed, must be electrically grounded in accordance with local codes or, in the absence of local codes, with the National Electrical Code, ANSI/NFPA 70, or the Canadian Electrical Code, CAN/CSA C22.1.

All electrical connections for the S50 are done internally and come pre-wired directly from the factory. Connect the supplied IEC power cord into the receptacle at the back of the unit (see Figure 60) and into a wall outlet.

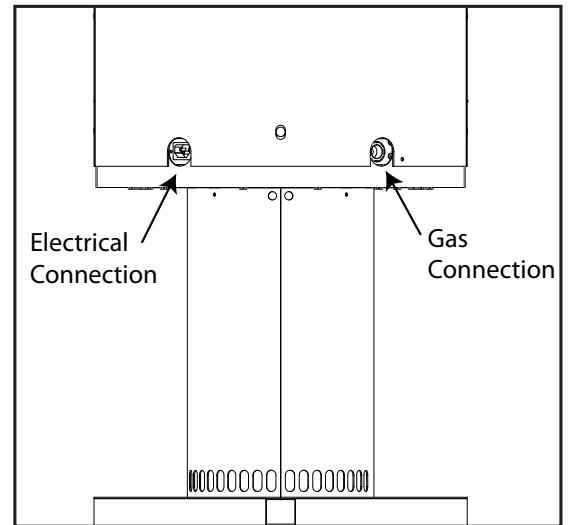

Figure 64: Electrical and Gas Connections

The electrical and/or gas connection can be reconfigured to come up through the pedestal for a cleaner look.

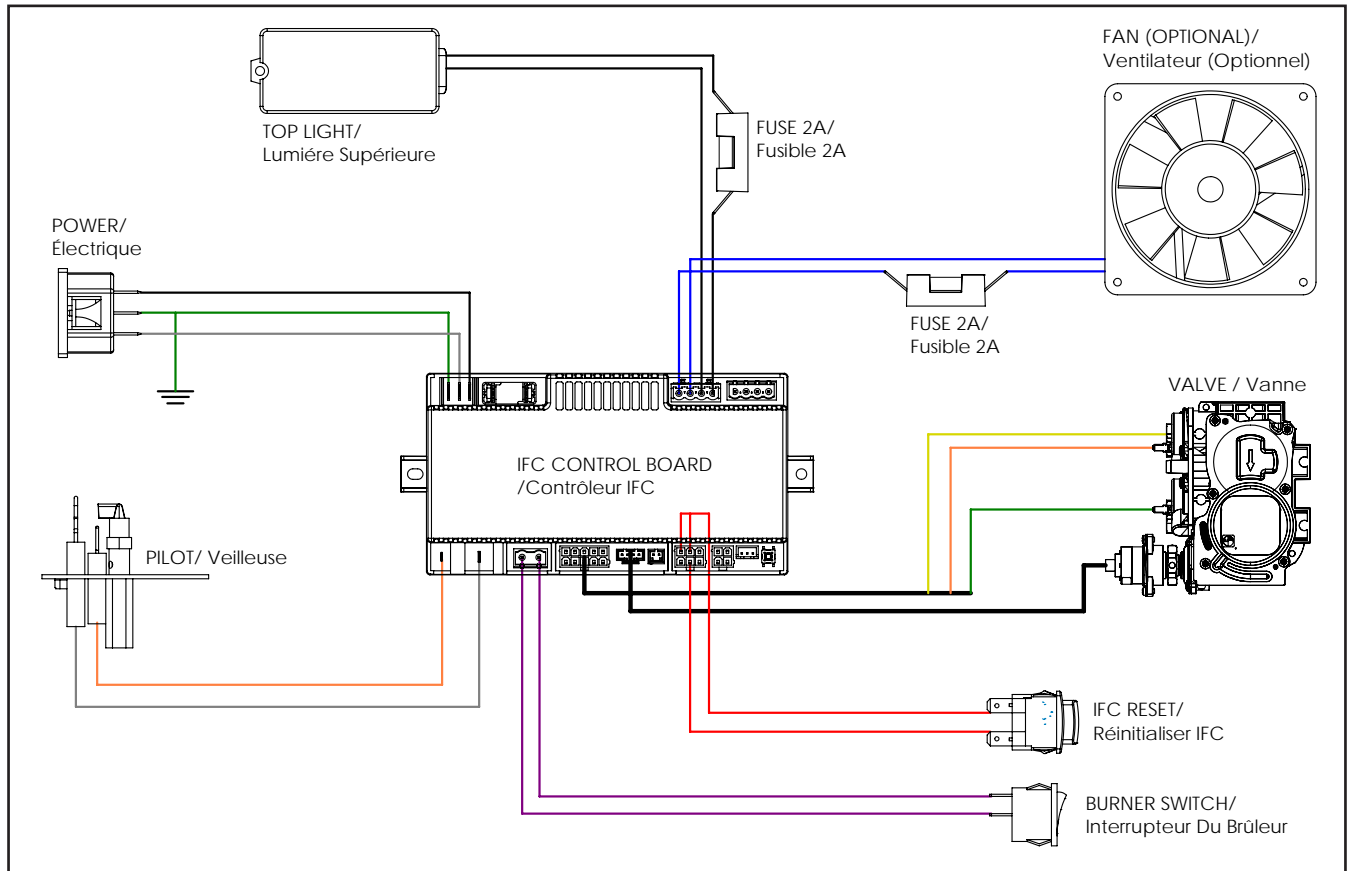

Figure 65: S50I Wiring Diagram

INITIAL INSTALLATION

QUALIFIED INSTALLERS ONLY

TOP PLATE COLLAR INSTALLATION

The top plate collar is an aesthetic band that helps hide the venting connection for top vent applications. Prior to installing the venting, place the collar on top of the unit around the vent adaptor (see Figure 66). The collar does not fasten to the unit but is heavy enough to sit in place securely.

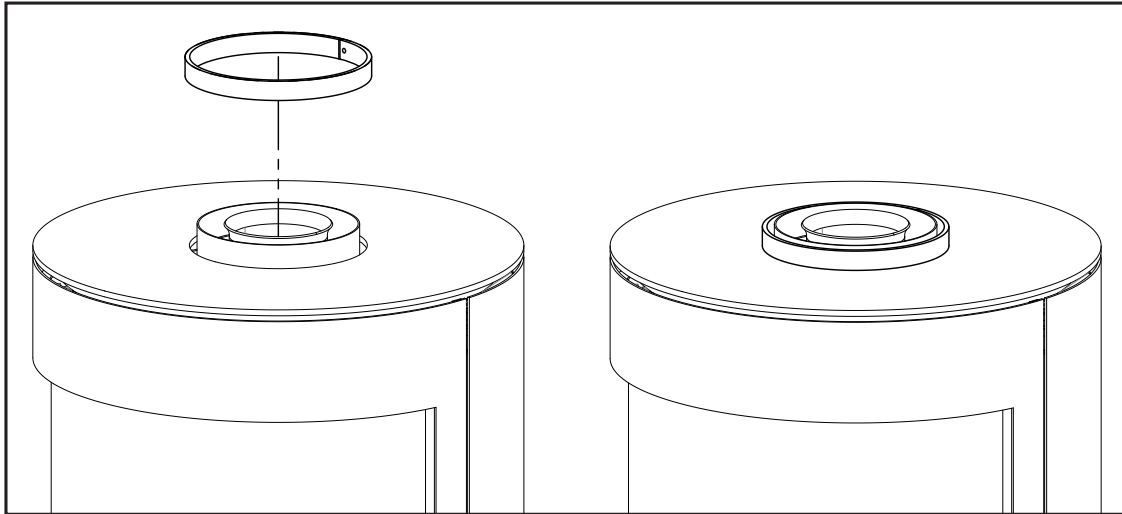

Figure 66: Top Plate Collar Placement

REAR VENT CONVERSION

The S50 has the option to be top or rear vented. By default, it comes configured as top vented from the factory. This can be changed by following these steps:

1. Remove the top plate from the unit (see section REMOVING TOP PLATE on page 23).
2. Remove the door frame and skirt from the unit (see section REMOVING DOOR FRAME/SKIRT on page 17).
3. Remove the glass from the unit (see section REMOVING GLASS on page 18).
4. Remove the rear chassis from the unit (see section REMOVING REAR CHASSIS on page 19).
5. Rotate the restrictor disk by hand from inside the firebox until the four (4) screw heads are exposed; remove them using a 5/16" socket (see Figure 67). The finger catch can be loosened and moved if it is inhibiting the movement of the restrictor.
6. Remove the threaded rod from the exhaust spigot (see Figure 68). A power drill with a 7/16" socket and extension will be helpful here.
7. Remove the vent adapter from the top of the unit by removing the four (4) T20 screws (see Figure 69). Be delicate with the gasket, you will be reusing this.

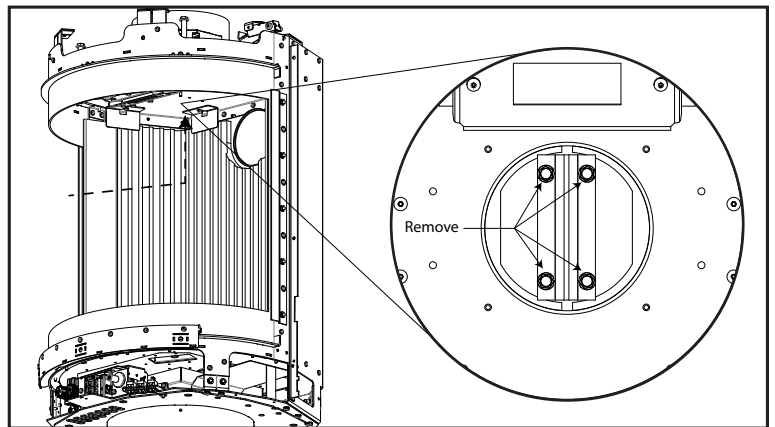

Figure 67: Restrictor Plate Removal

INITIAL INSTALLATION

QUALIFIED INSTALLERS ONLY

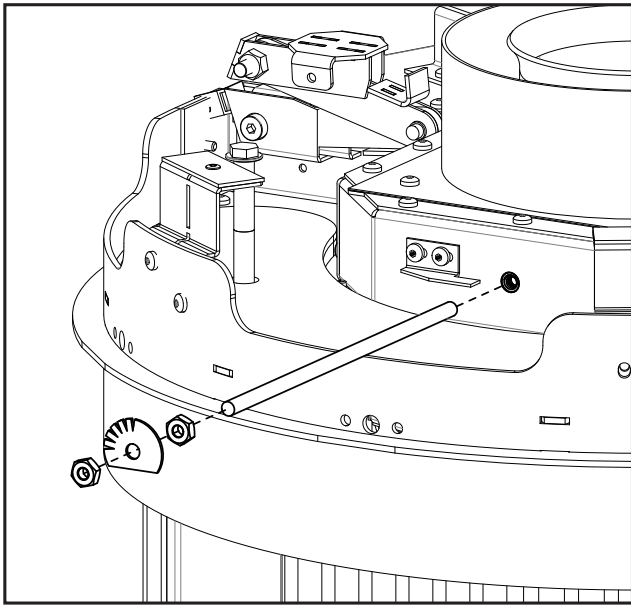

Figure 68: Restrictor Rod Removal

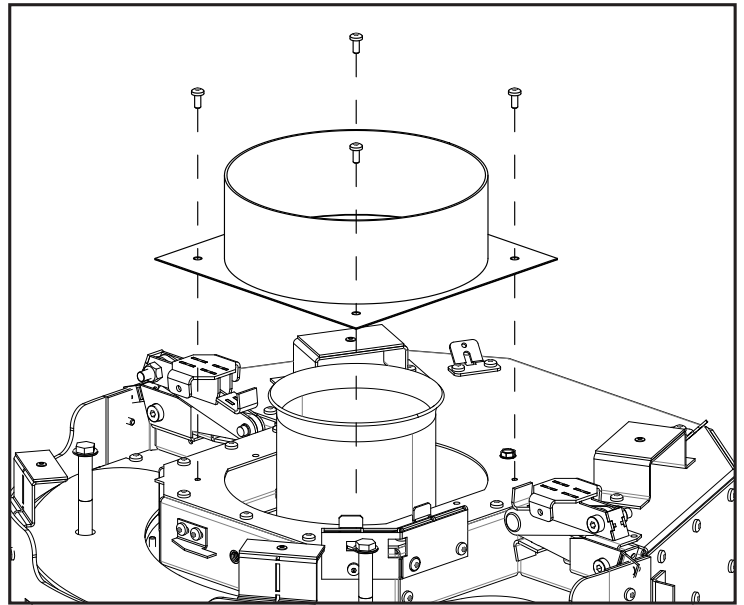

Figure 69: Vent Adapter Removal

8. Remove the exhaust spigot from the top of the unit by removing the four (4) T20 screws (see Figure 70). Be delicate with the gasket, you will be reusing this.
9. Remove the outer and inner block-off plates from the back of the unit and attach them to the top of the unit where the exhaust spigot and vent collar were attached (see Figure 71).

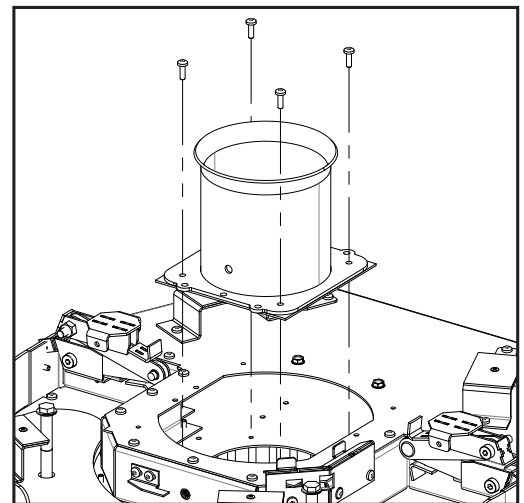

Figure 70: Exhaust Spigot Removal

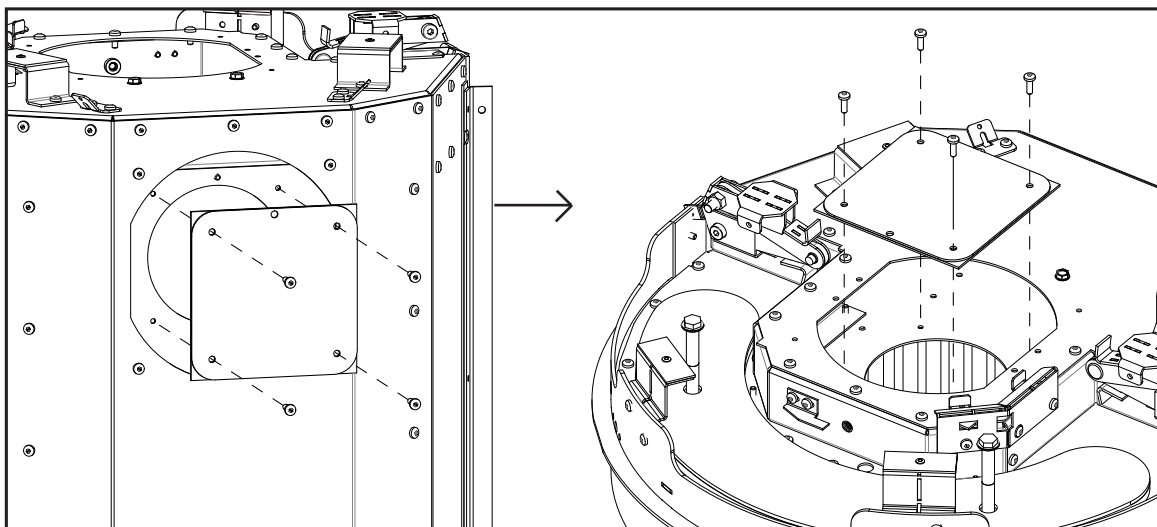

Figure 71: Inner Block-Off Plate Removal and Attachment

INITIAL INSTALLATION

QUALIFIED INSTALLERS ONLY

10. Attach the exhaust spigot to where the block-off plate was removed (see Figure 72).
11. Attach the vent adapter over top of the exhaust spigot (see Figure 73).
12. Remove the punchout from the rear chassis using a size-able hammer (see Figure 74). Place a cloth down around the perimeter to prevent damage to the chassis in case you accidentally strike the painted surface.
13. Reattach the rear chassis, glass, door frame, and top plate to the unit.
14. Place the top plate blank (included with the unit) into the top plate (see Figure 75).

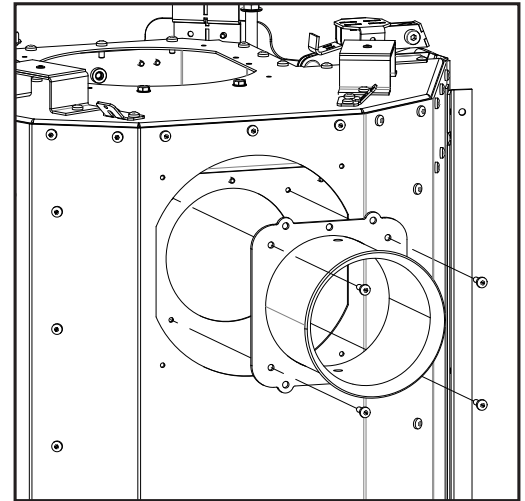

Figure 72: Exhaust Spigot Attachment

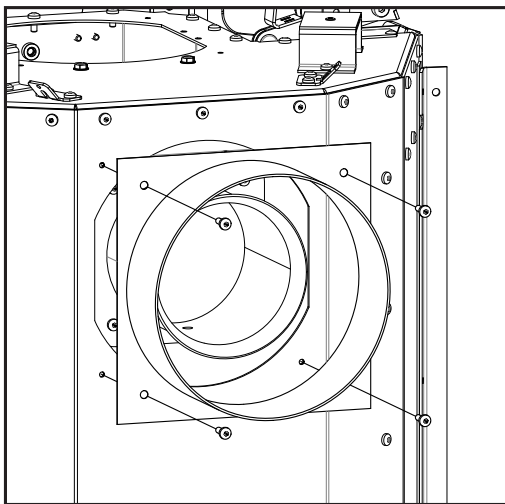

Figure 73: Vent Adapter Attachment

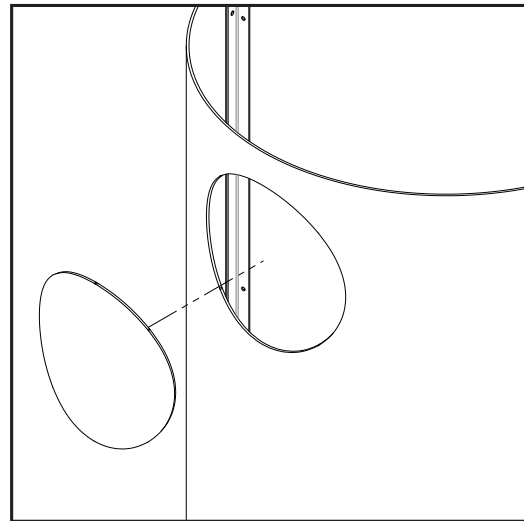

Figure 74: Rear Chassis Punchout

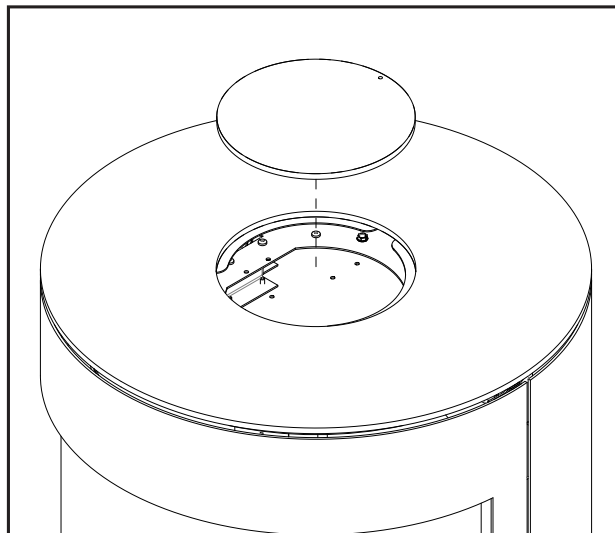

Figure 75: Top Plate Blank

INITIAL INSTALLATION

QUALIFIED INSTALLERS ONLY

PEDESTAL INSTALLATION

***Note: If planning to reroute the electrical and gas connections through the pedestal, complete the steps in section RELOCATING GAS/ELECTRICAL on page 49 before proceeding.**

The pedestal comes packaged with rigid foam to help secure and cushion it during transportation. To aid with the pedestal installation, save this foam as it can be used as a cushion for the unit.

Remove the 3 straps securing the unit to the pallet. Lay the foam behind the pallet and tip the unit back onto the cushion so there is easy access to its bottom.

Remove the four (4) bolts from the bottom of the unit (see Figure 76). These bolts are used to install the pedestal.

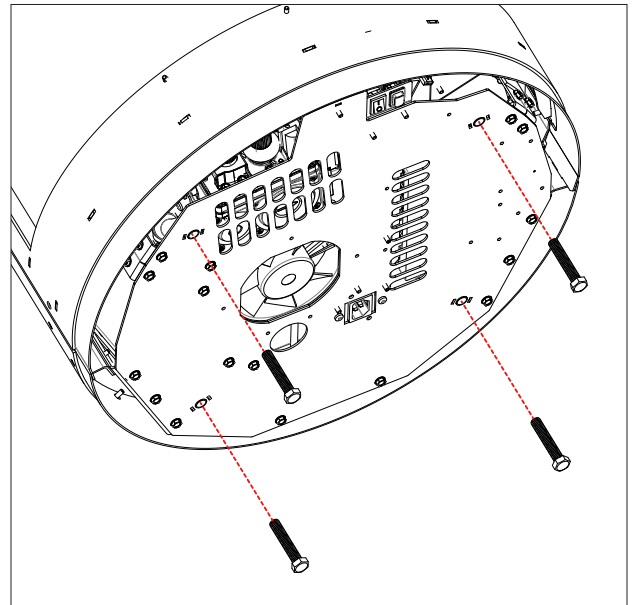

Figure 76: Pedestal bolt Removal

POLE PEDESTAL (50-4072 / 50-4078)

The pole pedestal comes packaged with four (4) hex head bolts and four to secure the pedestal onto the unit. Align the pedestal vent slots with those on the bottom of the unit. Fasten the pole pedestal to the unit using the same threaded holes that the leveling legs were installed in (see Figure 77).

***Note:** If rerouting the Gas/Electrical connections through the pedestal, make sure to complete the relocation prior to fully installing the pedestal.

Raise the unit upright.

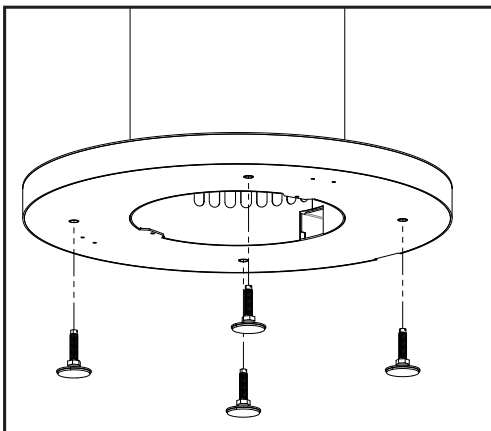

Figure 77: Pole Pedestal Leveling Feet

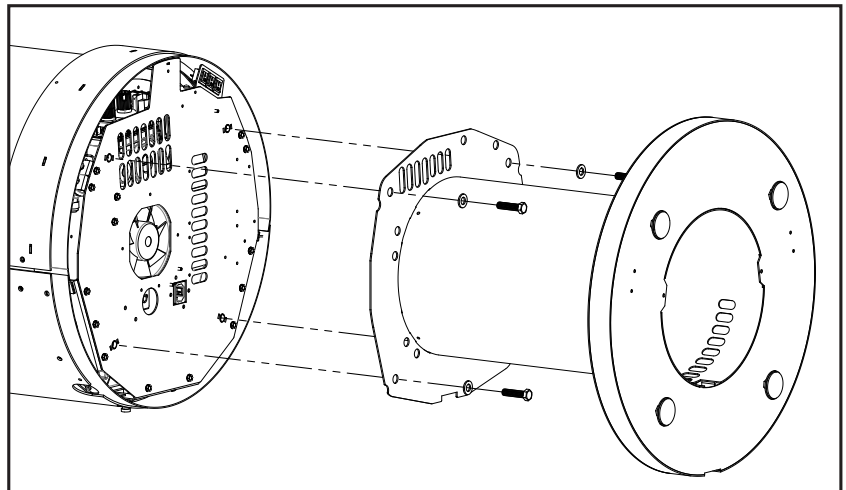

Figure 78: Pole Pedestal Installation

INITIAL INSTALLATION

QUALIFIED INSTALLERS ONLY

WOOD PEDESTAL (50-4073 / 50-4079)

The wood pedestal comes packaged with four (4) hex head bolts and four (4) washers used to secure the pedestal onto the unit. Fasten the wood pedestal to the unit using the same threaded holes that the leveling legs were installed (see Figure 81).

***Note:** If rerouting the Gas/Electrical connections through the pedestal, make sure to complete the relocation prior to fully installing the pedestal.

Raise the unit upright.

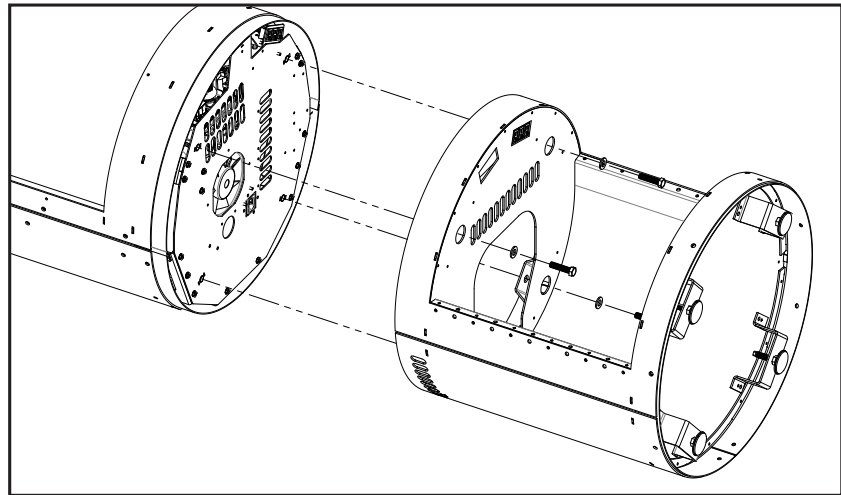

Figure 79: Wood Pedestal Installation

Floor Mounting Kit

The Pole pedestal & Wood Pedestal both come with an anchor plate to help secure it to the floor (see Figure 79 for geometry and orientation).

The Floor Mounting kit is optional, unless you are installing the S50 in a mobile home, where it is required.

Please refer to the Full Installation instructions included with the pole Pedestal or the Wood Pedestal

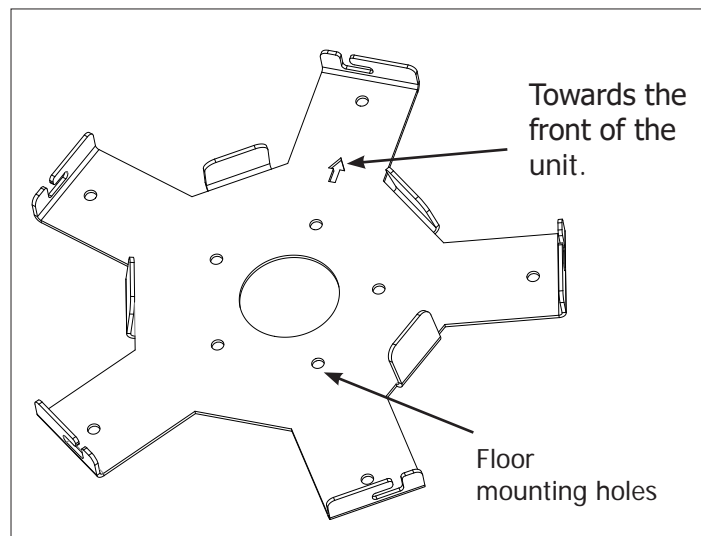

Figure 80: Pole Pedestal Anchor

INITIAL INSTALLATION

QUALIFIED INSTALLERS ONLY

MOBILE HOME INSTALLATION:

All S50 models can be installed in a mobile home and must be securely fastened to the floor as directed below:

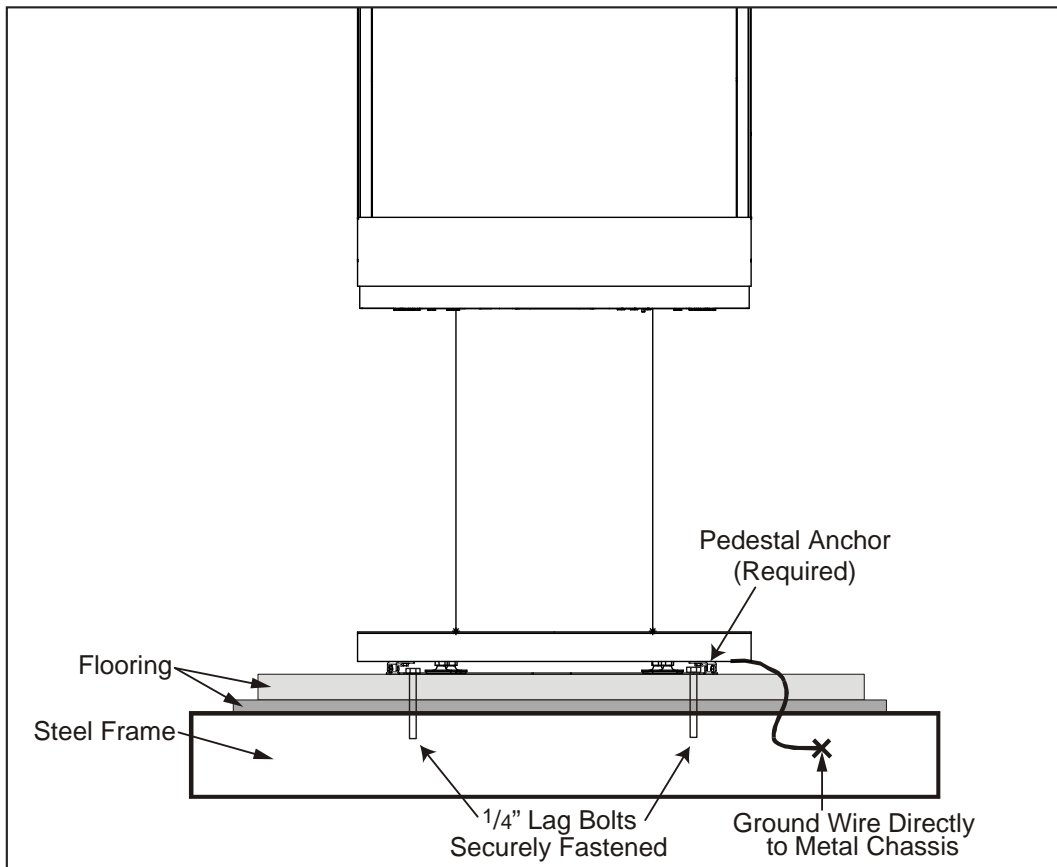

Figure 81: Correct Mobile Home Installation

Caution: The structural integrity of the manufactured home's floor, wall, and ceiling/roof must be maintained

INITIAL INSTALLATION

QUALIFIED INSTALLERS ONLY

RELOCATING GAS/ELECTRICAL

By default, the electrical and gas connections are found at the back of the unit. There is an option to reroute the gas and electrical connections through the pedestal for a more concealed look.

The conversion must be done before pedestal installation. The conversion can be made while the unit is still on the pallet - use the pedestal foam packaging as a cushion to tip the unit back onto for bottom access.

Start by removing the door frame, front skirt, and rear chassis (refer to their respective sections on page 17 to page 19 for more detailed instructions).

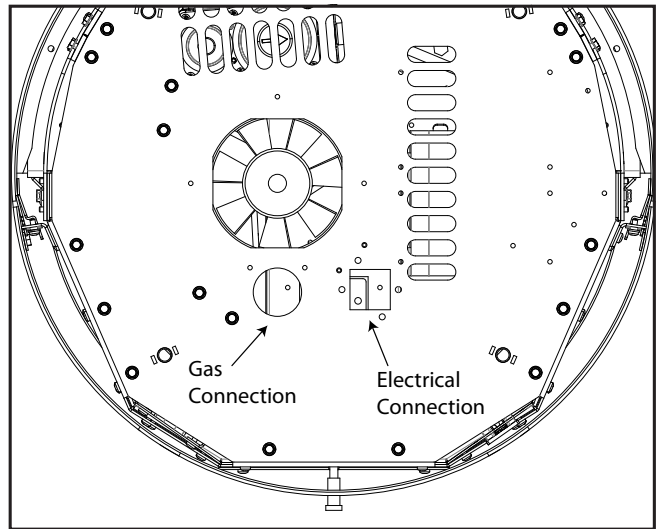

Figure 82: Gas & Electrical Connection Points (Bottom View)

RELOCATING ELECTRICAL CONNECTION

Caution: Label all wires prior to disconnection when servicing controls. Wiring errors can cause improper and dangerous operation. Verify proper operation after servicing.

1. Disconnect the IEC outlet plate (see Figure 83).
2. Disconnect the wires attached to the IEC electrical outlet and remove the outlet from the steel plate. Make note of how the plug is wired as it will need to be rewired shortly after.
3. Press the IEC outlet into the adapter plate (included in the manual bag). Refer to Figure 84 for proper geometry and orientation. **Make sure tangs are completely seated of the plug will not engage fully.**
4. Rewire the IEC electrical outlet and position over the hole shown in Figure 82.
5. Attach the adapter plate through the firebox reusing the two (2) T20 screws (see Figure 85).

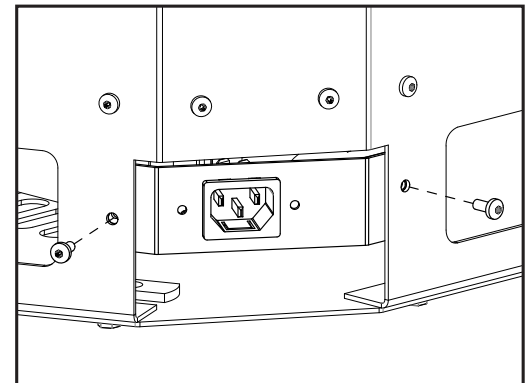

Figure 83: Electrical Plug Disconnect

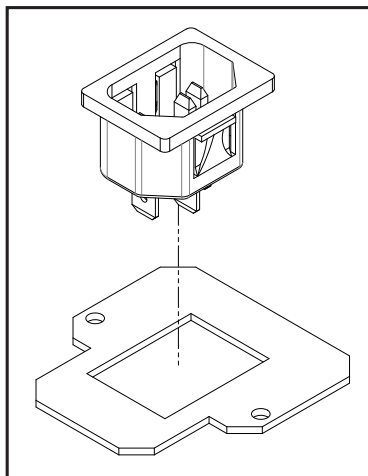

Figure 84: Electrical Adapter Plate

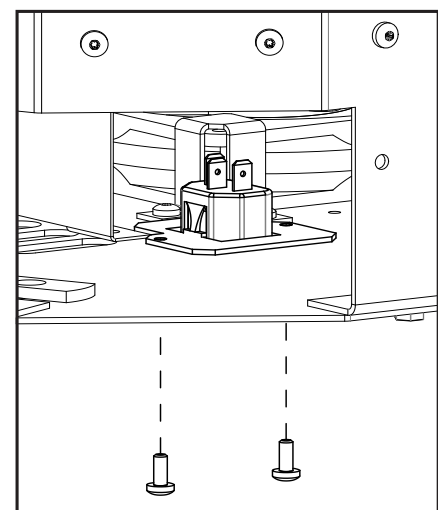

Figure 85: Electrical Plug Connection

INITIAL INSTALLATION

QUALIFIED INSTALLERS ONLY

RELOCATING GAS CONNECTION

1. Disconnect the two (2) T20 screws securing the ball valve plate (see Figure 86).
2. Disconnect the four (4) T20 screws securing the ball valve.
3. Loosen off ball valve jam screw and reattach ball valve cradle onto the relocation plate (included in the manual bag, refer to Figure 88 for proper geometry and orientation). Re-tighten jam screw and ensure ball valve is secure.
4. Use appropriate thread sealant and connect the 1/2" elbow fitting (included in the manual bag). Orientate the fitting downward.
5. Work the flex line and get the gas connection assembly into position as shown in Figure 90. Attach the assembly to the firebox using two (2) 5/16" hex head bolts from below.

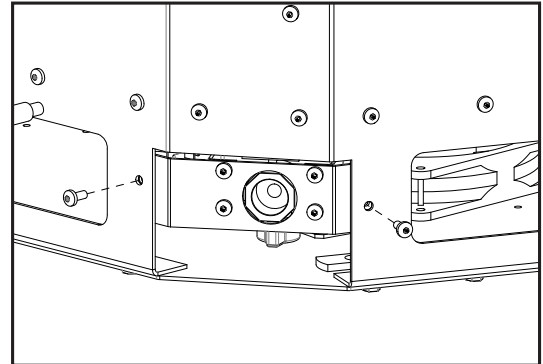

Figure 86: Gas Plate Disconnection

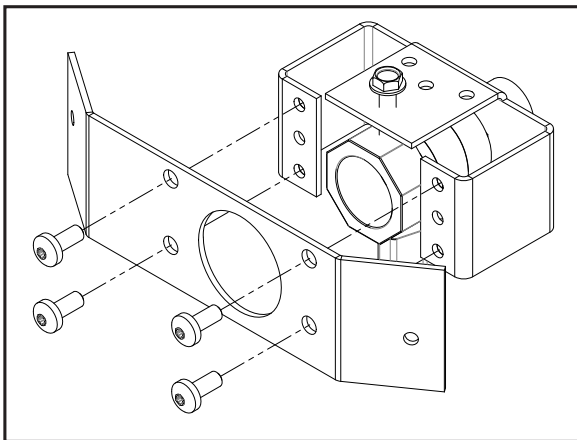

Figure 87: Gas Plate Removal

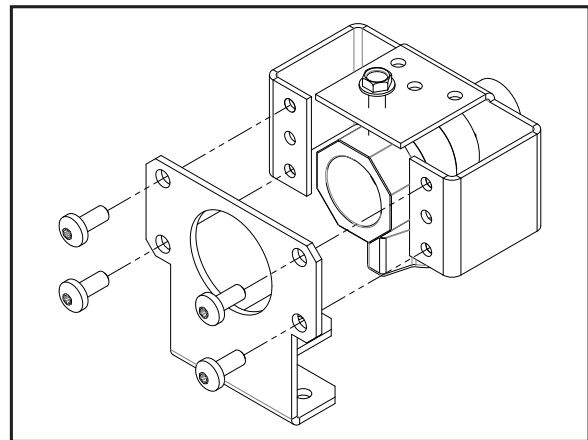

Figure 88: Gas Adapter Connection

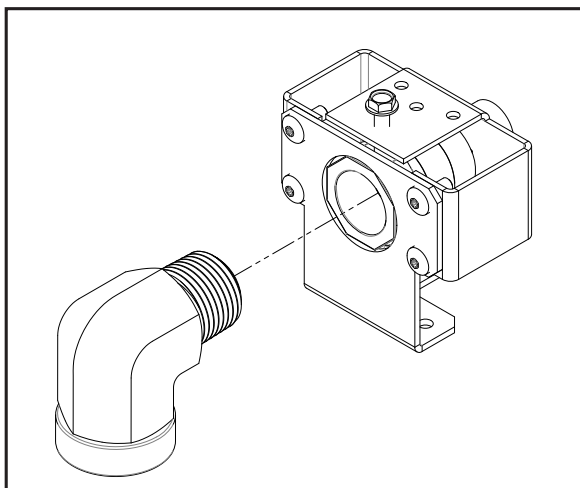

Figure 89: 1/2" Elbow Fitting Connection

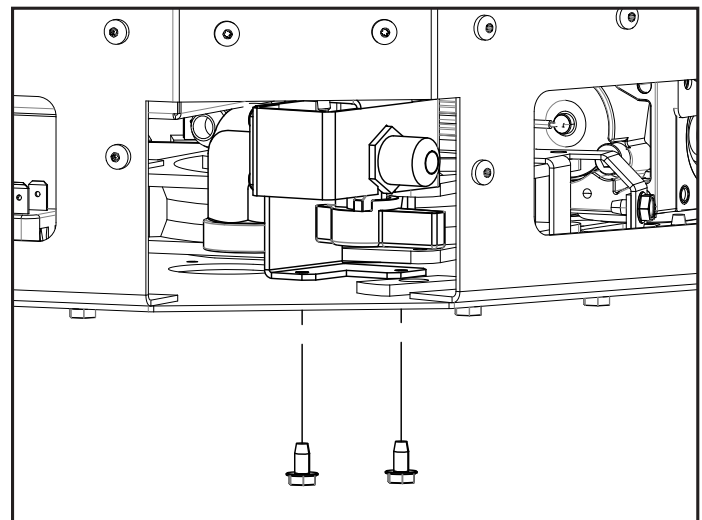

Figure 90: Gas Connection Re-installation

INITIAL INSTALLATION

QUALIFIED INSTALLERS ONLY

REROUTING GAS/ELECTRICAL CONNECTIONS - POLE PEDESTAL

The electrical and gas line conduit can run straight up the pole from the floor below. Alternatively you could run them through the channel at the rear of the pedestal base (see Figure 91).

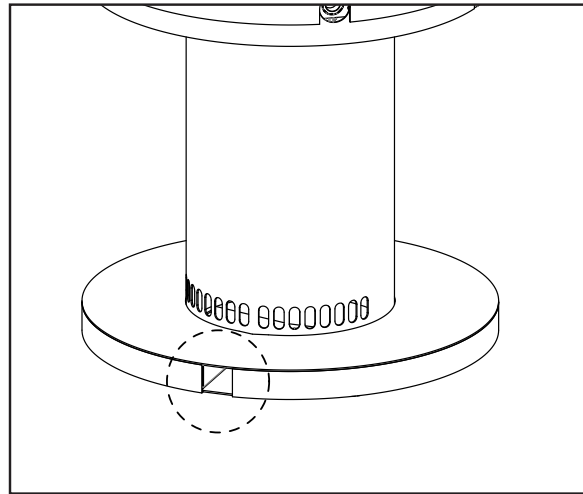

Figure 91: Pole Pedestal Gas & Electrical Rerouting

The wood pedestal has a knockout located at the top of its back wall that will allow the gas and electrical connection to pass through. This knockout allows access to the hollow back wall of the pedestal, which then leads to two (2) openings at the back of the pedestal (see Figure 92).

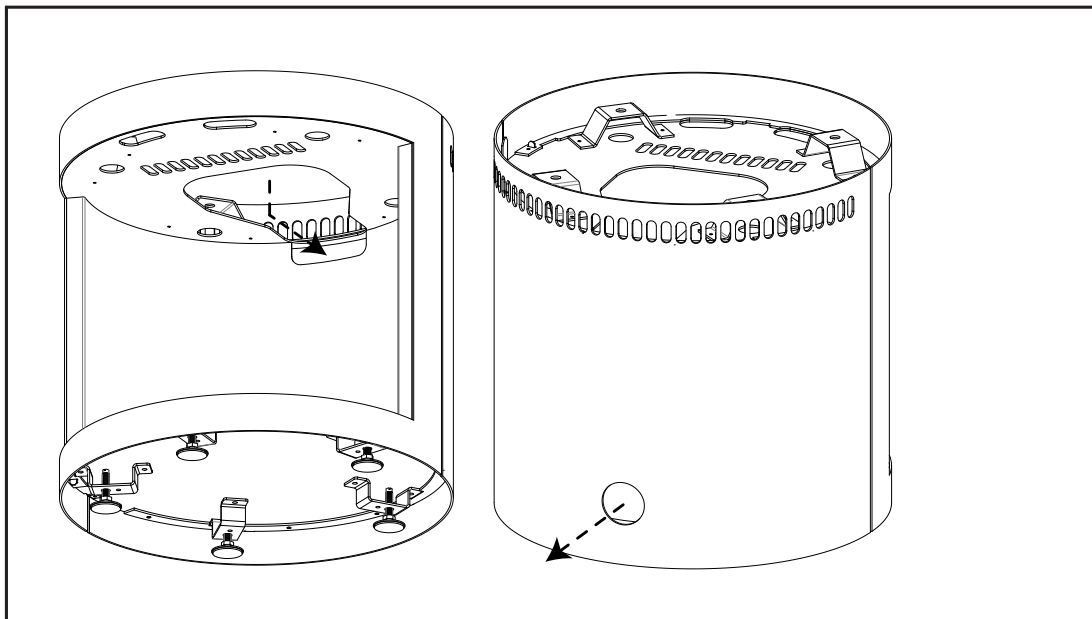

Figure 92: Wood Pedestal Gas & Electrical Rerouting

SECONDARY INSTALLATION

LOG SET INSTALLATION

Prior to setting up the log set, remove the door frame and glass from the unit. Refer to their respective sections on page 17 and page 18 for detailed instructions.

STEP 1: Place burner media on burner. Use either vermiculite or ember wool; if using ember wool, tear it apart into fine thin strands with your fingers - wear gloves. Do not cover up meshed air ports or burner air slots, these must remain clear.

STEP 2: Place Log 1 and into position as shown. Log 2 will support Log 1 in a distinctive area. Each log should be contacting side and rear liners and spaced off burner air slots by 1/4" (6mm). See Figure 93.



Figure 93: Step 2 - Log 1 & 2

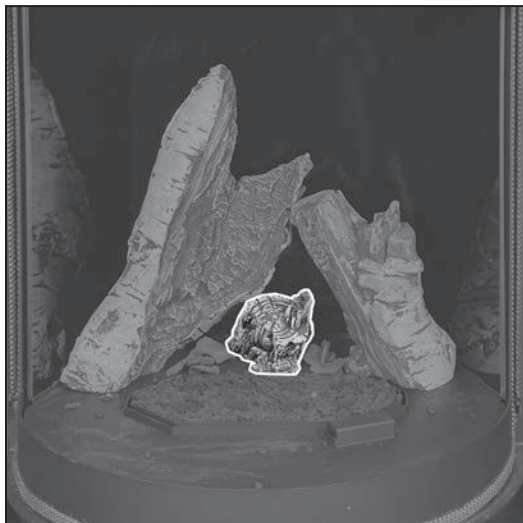

Figure 94: Step 3 - Log 3

STEP 3: Place the divot underneath Log 3 over the rear base screw head. Pivot the log slightly counterclockwise. Place shale and/or vermiculite on either side on the log as desired. See Figure 94.

STEP 4: Place the divot underneath Log 4 over the front base screw head. The orientation will need to be adjusted during the next step. See Figure 95.



Figure 95: Step 4 - Log 4



Figure 96: Step 5 - Log 5

STEP 5: The backside of Log 5 should be parallel to the burner but spaced off the air slot by 1/4" (6mm). Rotate Log 4 until the tip of Log 5 slots into the nook. See Figure 96.

SECONDARY INSTALLATION

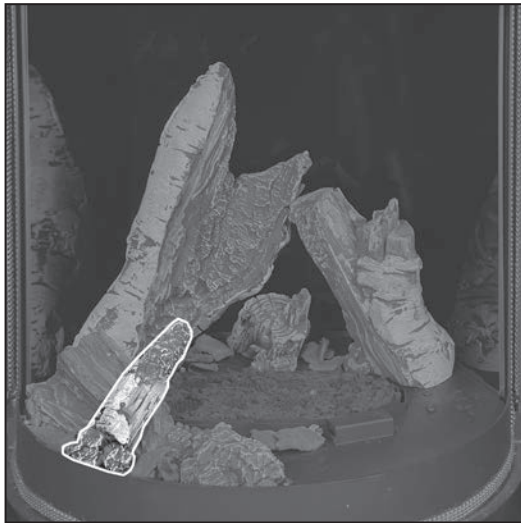

Figure 97: Step 6 - Log 6

STEP 6: Place Log 6 atop the flat surface of Log 5; the base should contact the firebox edge. See Figure 97.



Figure 98: Step 7 - Log 7

STEP 7: Place the narrow notch underneath Log 7 into the groove on Log 4. The right side of the log should contact the firebox edge and spaced off the burner slot by 1/4" (6mm). See Figure 98.

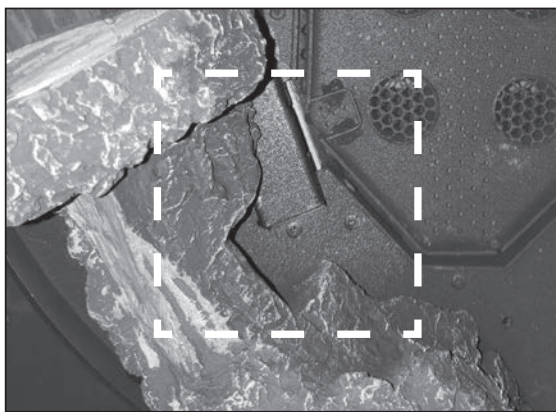

Figure 99: Log 7 Placement (Top View)

***Note:** It is important that Log 7 is placed correctly as specified in the instructions. There is a notch located on its back side (facing the burner) that should be placed to the right of the pilot as shown in Figure 99. Failure to place the log properly could result in problems with the pilot.

STEP 8: Log 8 should notch onto Log 7 nicely. See Figure 100.

STEP 9: Continue placing shale and/or vermiculite between the logs as desired. Do not cover up any air slots.

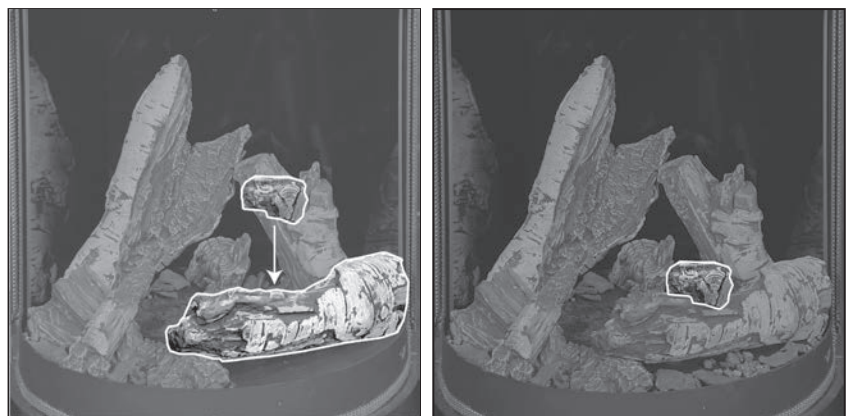

Figure 100: Step 8 - Log 8

SECONDARY INSTALLATION



Figure 101: Proper Log Setup/Burn

MEDIA INSTALLATION

To install media into your unit, perform the following steps:

1. Remove the door frame (refer to section REMOVING THE DOOR FRAME/SKIRT on page 17).
2. Remove the glass (refer to section REMOVING THE GLASS on page 18).
3. Place your burner media into the burner platform creating a thin layer that evenly covers the entire burner pan; pat it down gently.

***Note:** Ensure that the areas highlighted in Figure 102 are not covered by media. These areas must be clear to allow the proper flow of air. Failure to do so will cause the fireplace to not burn properly.

4. Reinstall the glass and door frame.

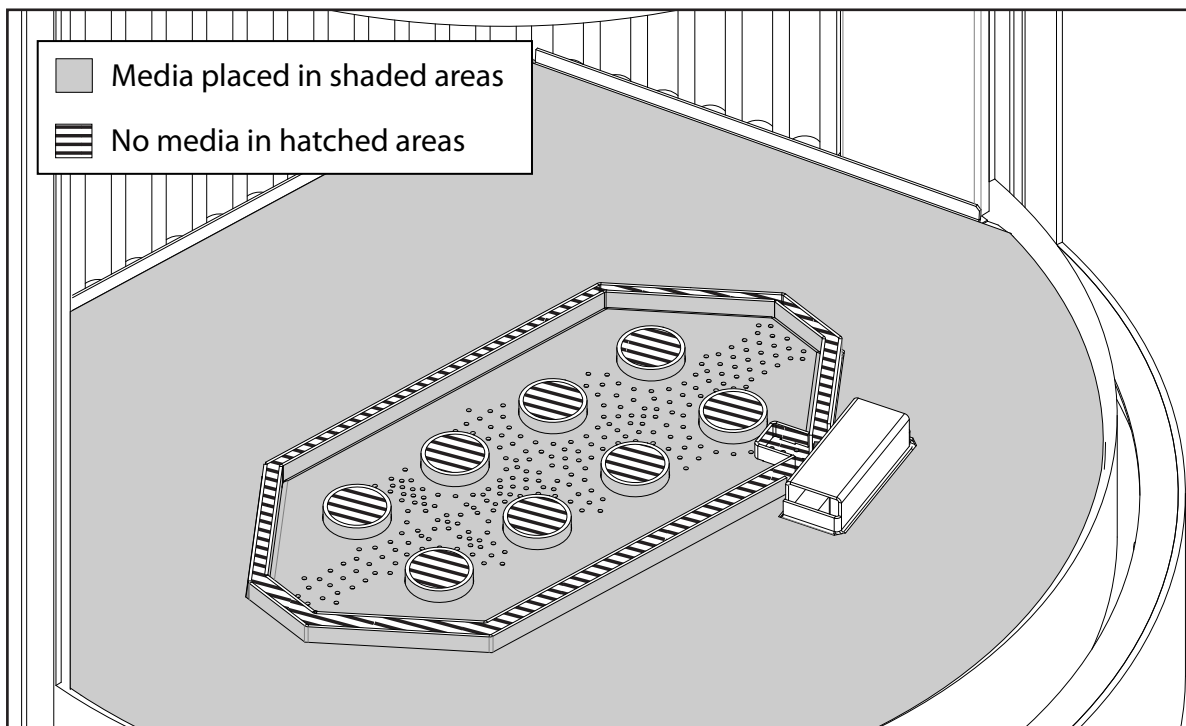

Figure 102: Media Installation Area

TROUBLE SHOOTING

Problem	Cause	Solution	Check (In order of likelihood)
Difficulty mounting door frame	Curved glass not seated properly Door sitting too high	Reset glass Door hooks not seating correctly	Check (In order of likelihood) Fully tighten front curved clamps before side clamps Follow the 2-step procedure using the different receiver hook steps
Burner doesn't turn on	IFC ON/OFF circuit is OPEN Remote signal not being received No call for heat	Ensure ON/OFF circuit is complete (check with multimeter) Ensure IFC is receiving remote commands (audible beeps) **Remote commands may need to be repeated Ensure heat has been called for	Check the ON/OFF switch, confirm " " symbol is pressed down Check for continuity across burner switch Re-sync remote Weak or dead remote batteries Check thermostat setting is below set point Check third party fireplace control
Pilot flame not attempting to spark	Unresponsive IFC Problem with pilot No call for heat	Ensure IFC is working correctly *audible beeps confirms IFC is getting power Ensure pilot flame is operational Ensure heat has been called for	Check IFC circuit breaker Check for 120VAC at IFC Check IFC fuse Check for red blinking light on IFC (see "IFC error" troubleshooting section) See "Pilot flame not lighting" below Check thermostat setting is below set point Check third party fireplace control
Pilot flame not lighting or weak flame (has spark at hood)	Locked out IFC Spark signal interrupted Air in pilot gas line Not enough gas pressure	Reset IFC Ensure complete sparkler circuit Purge pilot gas line Ensure gas is reaching pilot	See "Unresponsive fireplace" below Check electrode rod not shorting out on burner platform - adjust rod only if necessary Check electrode wire not shorting out (especially at aluminum pilot line) Check orange electrode wire has firm connection at IFC Check pilot electrode orientation to pilot hood - should be no more than 1/4" away May take a few ignition cycles for gas to self-purge (may need to hard reset IFC after cycles) Check gas inlet supply and pressure (see "Gas Connections") Check for complete wiring connections at valve (look for faux connections) Check pilot is set-up for correct fuel-type Check for pilot flame obstructions (typically burner media) Check for debris in pilot line at pilot head (typically propane units) Check pilot flame adjustment screw on valve Check for pilot line leak - do you smell gas?
Pilot flame not staying lit	7 continuous days with no burner operation Problem with flame sensor circuit	Re-start fireplace using remote Ensure healthy flame rectification	This is normal Ensure sensor hook is glowing bright red Check for healthy pilot; ensure sensor hook is fully engulfed in flame Check sensor hook is not touching pilot hood Check white sensor wire has firm connection with IFC Check sensor hook for corrosion, film, or debris Check pilot for healthy ground (check pilot hood continuity)
Flame drooping out (visual flame problems)	Exhaust Restrictor Setting Improper fireplace settings	Ensure correct exhaust restriction setting Ensure proper fireplace settings	See "Venting Configuration" Check exhaust restrictor setting; see "Venting Configuration" Check venting configuration is approved Check for venting obstructions (including at termination cap) Check primary air settings; see "Primary Air Adjustment"
Flame dropping out (no visual problems)	Weak or erratic pilot flame Environmental conditions (windy)	Ensure pilot flame is healthy Fireplace adjustment may be necessary	Check flame sensor circuit; see "Pilot flame not staying lit" Check for approved high-wind termination cap Check for proper fireplace settings (see above) Adjust exhaust restrictor only if necessary
Flame dropping out (no visual problems)	Environmental conditions (extreme cold) Not enough gas supply Problem with pilot circuit	Use "Continuous Pilot" mode (CPI) Ensure proper gas flow and pressure Ensure pilot is operational	This will help the fireplace establish draft when freshly turned on Check fuel supply and gas test ports (see "Gas Connections") See "Pilot flame not staying lit"
Flame lifting	Too much primary air Exhaust restrictor setting Problem with venting system	Decrease primary air by closing air shutter (venturi) Improper exhaust restrictor setting Ensure venting system is properly set-up	See "Adjusting Primary Air Setting" See "Venting Configuration"; adjust only if necessary Check for approved high-wind termination cap Check venting configuration is approved Check for leaks in venting system

TROUBLE SHOOTING

	Input rate too high	Ensure correct gas orifice size and manifold pressure	See rating label for details
	Trouble establishing draft (weather related)	Use "Continuous Pilot" mode (CPI)	This will help the fireplace establish draft when freshly turned on
Flame weaving, bending or uneven (some is normal)	Poor firebox seal	Ensure glass is seated correctly	Curved door clamps must be completely tightened BEFORE side clamps
		Ensure firebox sealed	Check for damaged fiberglass perimeter tape Check for damaged or misalignment of pressure relief door gaskets
	Uneven secondary air distribution	Ensure burner platform is secured	Check for missing or stripped screws
	Incorrect media placement	Ensure even air slot gap around burner Ensure secondary air slots are cleared	Check for warping in burner platform (when installed) Check for pilled up burner media covering mesh air slots (vermiculite/glass media) Check for logs/rocks covering or too close to air slots Check for excessive burner media (no more than 1 layer thick) Check for foreign burner media
	Leaking burner	Ensure burner is sealed	Visually inspect burner for leaks; replace if necessary - DO NOT TEST WITH OPEN FLAME
Blue flames (excessive)	Fireplace is warming up	Flames will yellow as fireplace heats up	This is normal
	Too much primary air	Decrease primary air by closing air shutter (venturi)	See "Adjusting Primary Air Setting"
	Exhaust restrictor setting	Improper exhaust restrictor setting	Poor air shutter seal on venturi box - check threaded rod length See "Venting Configuration"; adjust only if necessary
Rich flames (excessive)	Not enough primary air	Increase primary air by opening air shutter (venturi) Remove air shutter for even more primary air (NG)	See "Adjusting Primary Air Setting"
	Improper exhaust restrictor setting	Adjust exhaust restrictor setting	Check that the venturi box cover is removed (LP)
	Problem with venting system	Ensure venting system is properly set-up	Check for approved high-wind termination cap Check venting configuration is approved Check venting system for leaks
	Incorrect media placement	Adjust burner media	Check log positioning
	Incorrect gas input rate	Ensure gas input spec's match rating label	Check burner media quantity (should be one layer deep) Check for obstructed secondary air slots around burner
	Condensation is formed on start up	Use "Continuous Pilot" mode (CPI)	Check gas inlet pressure Check gas manifold pressure (with unit running) Check gas orifice matches rating label for correct fuel type
Glass fogs on start-up	Additives in gas accumulates on glass	Use "Continuous Pilot" mode (CPI)	This is normal, more so in damper climates
Fireplace gets excessively hot	Problem with venting system	Ensure venting system is properly set-up	This will reduce the build-up rate; clean as necessary
	Exhaust restrictor setting	Exhaust restrictor setting too high	Check venting configuration is approved Check for venting obstructions
	Incorrect gas input rate	Ensure gas input spec's match rating label	Reduce exhaust restriction
	Flame sensor signal lost during burner operation	Ensure healthy burner operation	Check gas inlet pressure Check gas manifold pressure (with unit running) Check gas orifice matches rating label for correct fuel type
IFC locked out (flashing red light)	Pilot ignition sequence timed out	Ensure healthy pilot operation	See "Flame dropping out."
	Fireplace lost gas supply	Ensure proper gas flow and pressure	See "Pilot not lighting."
	IFC confused	Soft reset IFC Hard reset IFC	Check gas inlet supply and pressure Press reset button on fireplace switch panel and re-sync remote (tool may be required) Cut power to IFC (could use circuit breaker) and reconnect
Fireplace unresponsive	No power to fireplace	Ensure the fireplace is seeing 120VAC	Check circuit breaker Do any fireplace features work? If so, fireplace has power
	Blown IFC fuse	Replace IFC fuse with exact replacement	Check for bare electrical connections Check for electrical short in top light box Was there a recent power surge?
	IFC locked out	Reset IFC	See "IFC locked out" for possible causes

PARTS LIST

Reference Number	Description	Part Number
1	S.I.T. 885 Valve w/ NG Stepper Motor	50-2682
2	PSE IPI Pilot Assembly (2021)	50-4058
-	SIT IPI NG to LP Conversion (Stepper Motor ONLY)	50-3753
-	SIT IPI LP to NG Conversion (Stepper Motor ONLY)	50-3870
3	Proflame 2 IFC	50-4103
-	Proflame 2 IFC Wire Harnes (0.584.924)	50-3030
4	Top Light Assembly	50-4057
-	G9 25W 120V Bulb	50-4119
5	IFC Reset Button	50-3518
6	Rocker Switch (Burner Switch)	50-3892
7	S50 Fan Only	50-4177
8	S50 Pilot Fence w/ Gasket	50-4178
9	S50 Burner Assembly	50-4179
10	S50 Burner Platform Assembly	50-4180
11	S50 Top Plate - Carrara White	50-4276
-	S50 Top Plate - Metallic Black	50-4277
12	S50 Top Plate Collar	50-4182
13	S50 Top Plate Blank - Carrara White	50-4183
-	S50 Top Plate Blank - Metallic Black	50-4245
14	S50 Top Plate Fascia Band	50-4278
15	S50 Curved Glass	50-4188
16	S50 Door Frame - Carrara White	50-4189
-	S50 Door Frame - Metallic Black	50-4243
17	S50 Door Frame Hooks	50-4190
18	S50 Front Skirt	50-4191
29	S50 Rear Skirt	50-4192
20	S50 Rear Chassis - Carrara White	50-4193
-	S50 Rear Chassis - Metallic Black	50-4242
21	S50 Fluted Liner Set	50-4076
-	S50 Black Glass Liner Set	50-4075
22	S50 Pole Pedestal - Metallic Black	50-4072
-	S50 Pole Pedestal - Carrara White	50-4078
23	S50 Wood Pedestal - Metallic Black	50-4073
24	S50 Safety Screen	50-4141
25	Proflame 2 Transmitter (0.584.080)	50-3888
-	S50 River Rock Set with Twigs	50-3838
-	S50 Traditional Log Set	50-4069
-	S50 Birch Log Set	50-4070
-	S50 Diamond Glass Media	50-4071
-	2A Glass Fuse	50-2075
-	S50 IPI Circulation Fan Kit - 70 CFM	50-4247
-	S50I Owner's Manual	50-4246
-	12 oz. Can of Metallic Black Touch Up Paint	PAINT-12-MB

PARTS LIST

Reference Number	Description	Part Number
-	2A Glass Fuse	50-2075
-	S50 IPI Circulation Fan Kit - 70 CFM	50-4247
-	S50I Owner's Manual	50-4246
-	12 oz. Can of Metallic Black Touch Up Paint	PAINT-12-MB

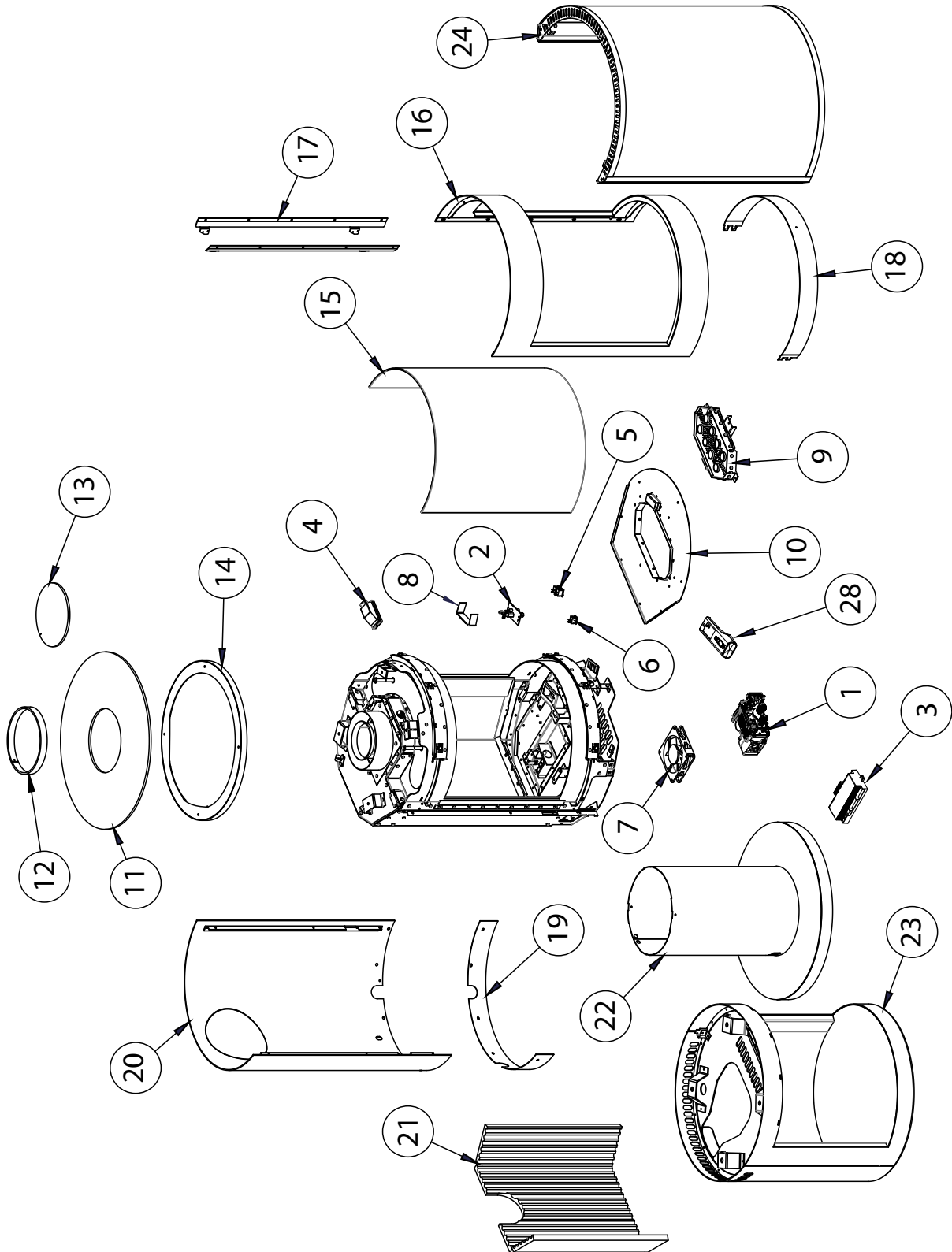

Figure 103: Parts List Diagram



Warranty for Enviro Gas Products

Sherwood Industries Ltd. ("Sherwood") hereby warrants, subject to the terms and conditions herein set forth, this product against defects in material and workmanship during the specified warranty period starting from the date of original purchase at retail. In the event of a defect of material or workmanship during the specified warranty period, Sherwood reserves the right to make repairs or to assess the replacement of a defective product at Sherwood's factory. The shipping costs are to be paid by the consumer. All warranties by Sherwood are set forth herein and no claim shall be made against Sherwood on any oral warranty or representation.

Conditions

- A completed warranty registration must be submitted to Sherwood within 90 days of original purchase via the online warranty registration page or via the mail-in warranty registration card provided. Have the installer fill in the installation data sheet in the back of the manual for warranty and future reference.
- This warranty applies only to the original owner in the original location from date of install.
- The unit must have been properly installed by a qualified technician or installer, and must meet all local and national building code requirements.
- The warranty does not cover removal and re-installation costs.
- Sherwood Industries Ltd. reserves the right to make changes without notice.
- Sherwood Industries Ltd. and its employees or representatives will not assume any damages, either directly or indirectly caused by improper usage, operation, installation, servicing or maintenance of this appliance.
- A proof of original purchase must be provided by you or the dealer including serial number.
- This warranty does not cover any discoloration of the safety screen mesh.

Exclusions

An expanded list of exclusions is available at www.enviro.com/help/warranty.html

This warranty does not cover:

- Damage as a result of improper usage or abuse.
- Damage caused from over-firing due to incorrect setup or tampering.
- Damage caused by incorrect installation.

To the Dealer

- Provide name, address and telephone number of purchaser and date of purchase.
- Provide date of purchase. Name of installer and dealer. Serial number of the appliance. Nature of complaint, defects or malfunction, description and part # of any parts replaced.
- Pictures or return of damaged or defective product may be required.

To the Distributor

- Sign and verify that work and information are correct.

Sherwood Industries Ltd.

6782 Oldfield Road, Victoria, BC . Canada V8M 2A3
 Online warranty registration: www.enviro.com/warranty/

Category	One Year	Two Year	Limited Lifetime (7yr)
Parts ^{1,2} (unit serial number required)		✓	
Firebox Liner Panels ³		✓	
Firebox			✓
Heat Exchanger			✓
Burner			✓
Ceramic Logs ⁴			✓
Ceramic Glass ⁵	✓		
Pedestal / Legs (excluding finish)			✓
Door Assembly			✓
Surround Panels (excluding finish)			✓
Exterior Panels (excluding finish)			Up to 5 years
Electrical Components		✓	
Exterior Surface Finishing	✓		
Labour	✓		

¹ Whereas warranty has expired, replacement parts will be warranted for 90 days from part purchase date. Labour not included. Unit serial number required.

² 50-173 Westport Fan Kit covered for up to 5 years from purchase date. Labour not included. Unit serial required.

³ Excluding damage to the finish caused by improper setup of the appliance, or color changes.

⁴ Log set and panels excludes wear and tear or breakage caused by cleaning or service.

⁴ Glass is covered for thermal breakage. Photos of box, inside of door, and unit serial # must be supplied for breakage due to shipping.

⁶ Exterior Surface finishing covers plating, enamel or paint and excludes colour changes, chipping, and fingerprints. Travel costs not included.

INSTALLATION DATA SHEET

The following information must be recorded by the installer for warranty purposes and future reference.

NAME OF OWNER: _____

ADDRESS: _____

PHONE: _____

NAME OF DEALER: _____

ADDRESS: _____

PHONE: _____

MODEL: _____

SERIAL NUMBER: _____

DATE OF PURCHASE: _____ (dd/mm/yyyy)

DATE OF INSTALLATION: _____ (dd/mm/yyyy)

NATURAL GAS (NAT) PROPANE(LPG)

INLET GAS PRESSURE: _____ in wc

MAIN BURNER ORIFICE: _____ # DMS

PILOT ORIFICE # _____ OR _____ in diam.

INSTALLER'S SIGNATURE: _____

NAME OF INSTALLER: _____

ADDRESS: _____

PHONE: _____

MANUFACTURED BY:
SHERWOOD INDUSTRIES LTD.
6782 OLDFIELD RD. SAANICHTON, BC, CANADA V8M 2A3
www.enviro.com
Winter 2022
C-16580