



G50 FIREPLACE

Installation Reference Guide

REFER TO OWNER'S MANUAL FOR SPECIFIC INSTALLATION REQUIREMENTS AND ADDITIONAL PRODUCT INSTRUCTIONS

Minimum Framing Dimensions

Note: When framing the unit, core must be taken to consider the final floor thickness, the bottom of the fireplace must sit flush with the finished floor to ensure proper fit of the surround components

Note: Vent size: 5/8

Depth	23 1/4"	590 mm
Width	55"	1397mm
Header Height	50"	1270 mm
Enclosure Ceiling	78"	1981 mm

**1" 25mm
Clearance from
framing studs
to venting**

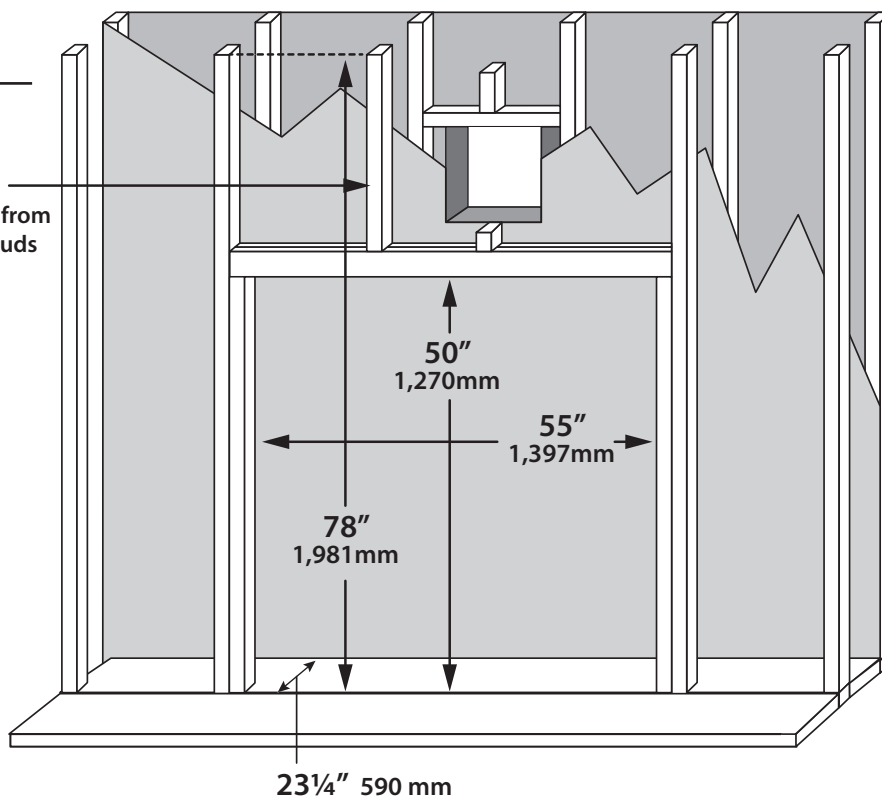

Clearance to Combustibles

A - Finishing edge to side wall	7"	178 mm
B - Minimum clearance to enclosure ceiling	78"	1981 mm
C - Minimum clearance to mantel height	See Chart	See Chart
D - Front of door to edge of floor protection	0"	0 mm
E - Minimum alcove width	65"	1,651 mm

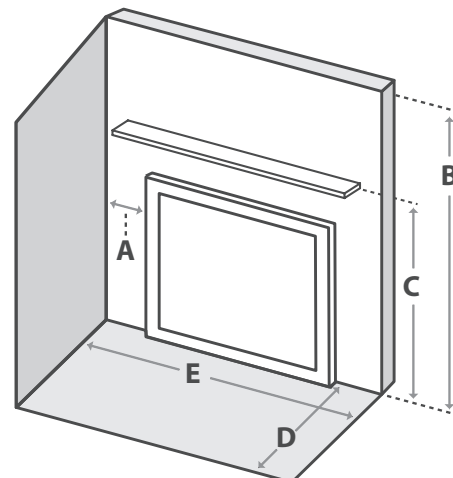

Non-Combustible Board Placement

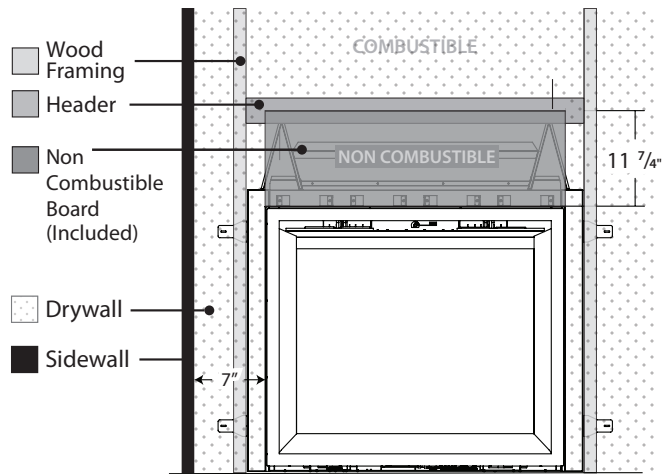

Minimum Venting Requirements

This appliance uses a 5" (127mm) exhaust / 8" (203mm) air intake vent pipe system. For safe and proper operation of the appliance follow the venting instructions exactly. Deviation from the minimum vertical length can create difficulty in burner start-up and sooting. Allow several minutes for the flame to stabilize after ignition under extreme vent configurations. It is recommended for vent lengths that pass through unheated spaces (garages, attics, crawl spaces) be insulated to minimize condensation.

NOTE: At least 3" (76mm) of clearance is required above vent when passing through an exterior wall when horizontally terminating.

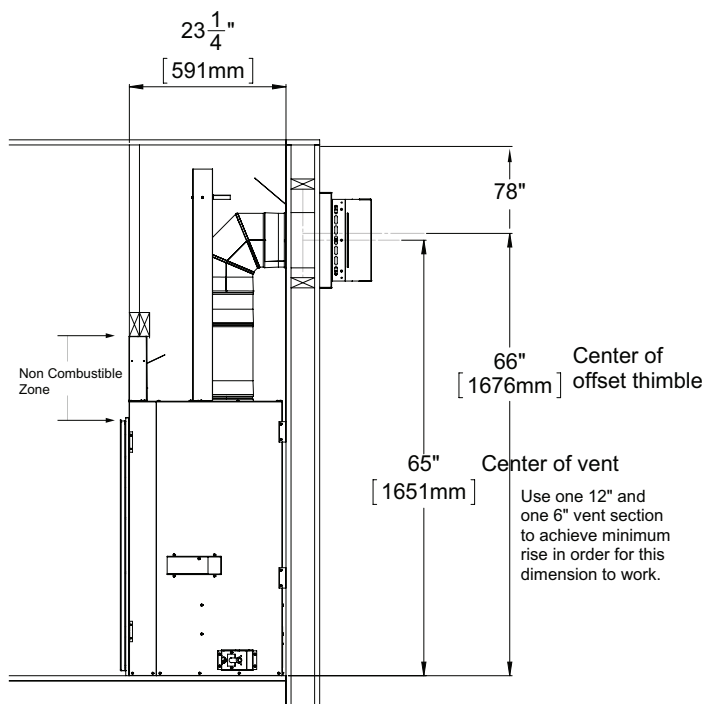

Fireplace Dimensions

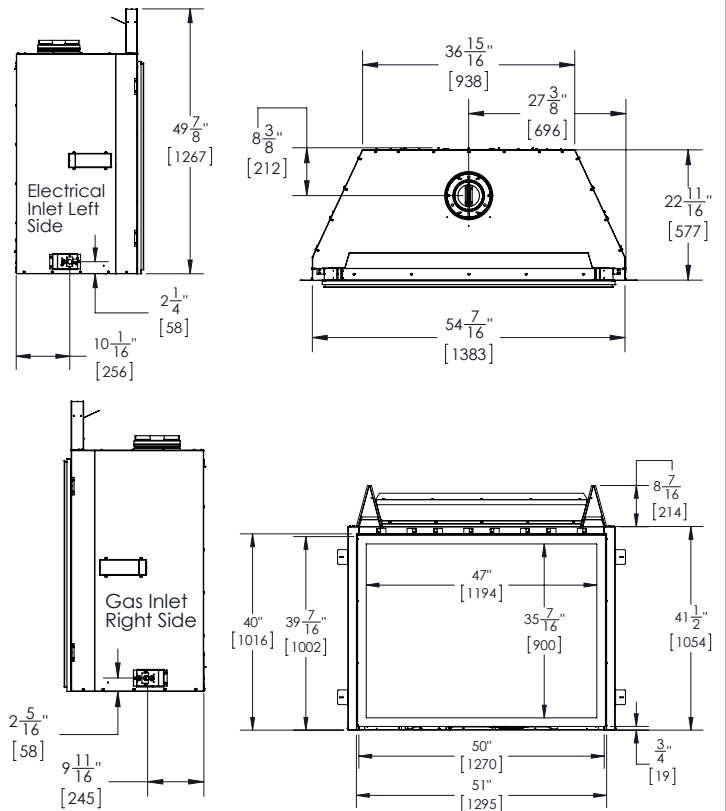

Mantel Projections

Mantel graph dimensions are measured from the bottom of the fireplace, if you wish to reference the mantel height from the tiling edge subtract 38 inches (965mm) from the mantel height depicted on the graph. If you plan to install a TV above your fireplace refer to the appropriate section of the owner's manual for available options. It is acceptable to install a combustible mantel over top of the non-combustible board. **If you are activating the Cool Surface System you are eligible to subtract 4" (102mm) from the mantel height shown in this diagram.**

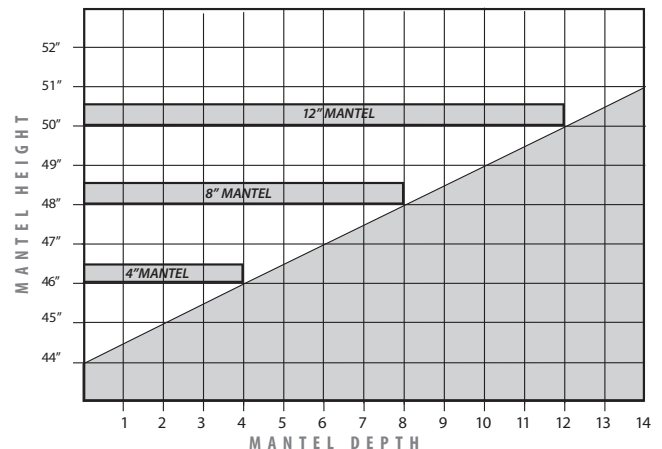

Cool Surface System Framing

Framing Option 1: Front Discharge (flush wall installations)

Construct the framing in a way that provides a minimum 55 inch (1397mm) by 3 inch (76mm) gap at the top of the facing wall. It is essential that these dimensions are respected and not to deviate away from them when using combustible materials inside the chase (see Figure 34).

Note: If you wish to construct the CSS air discharge part way up a tall wall then it is essential to build a false ceiling inside the chase at the desired height to direct the rising heat out of the gap.

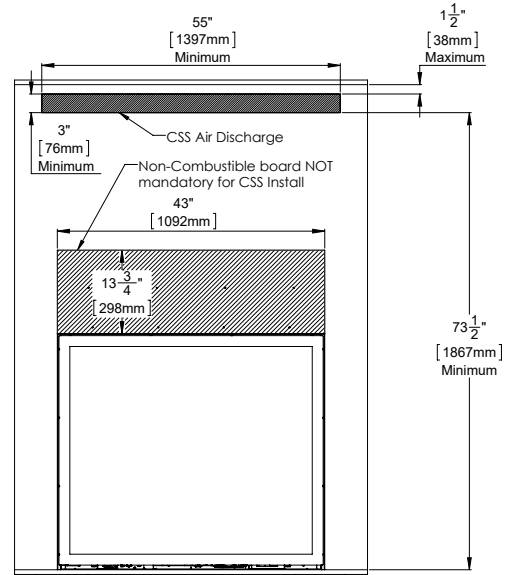

Figure 34: Framing Option 1

Framing Option 2: Open Chase (built-out installations)

This could be considered the most discreet option when considering the CSS. The chase must be constructed in a way that stops short of the ceiling, leaving it totally vented above. Minimum framing dimensions must be followed when constructing this option and not to deviated from them when using combustible materials. Consider Optional 3: Valance to work in conjunction with this option.

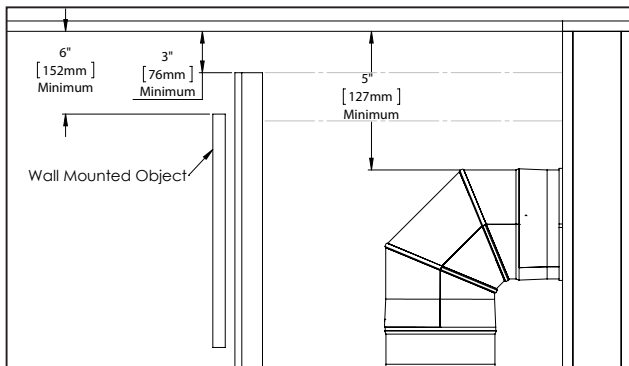

Figure 35: Option 2

Framing Option 3: Valance

A valance may be desired to accentuate or hide the CSS outlet. Consider framing option 1 or 2 to utilize the valance feature. This is an optional decorative feature that covers up the CSS outlet gap. Minimum opening and valance dimensions must be followed to ensure safe heat dissipation. Combustible material is acceptable when constructing the valance. It is acceptable to wrap the valance around the three sides of a built out chase (Option 2).

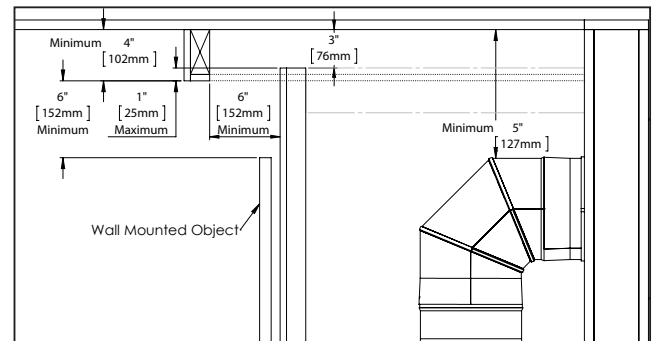

Figure 37: Valance Install

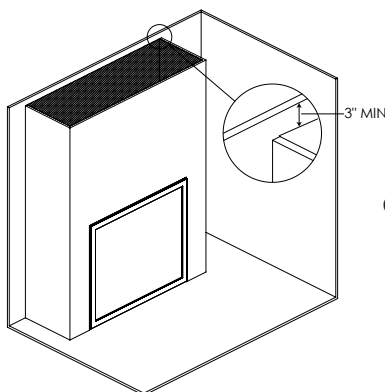

Figure 36:
Open Chase Iso View

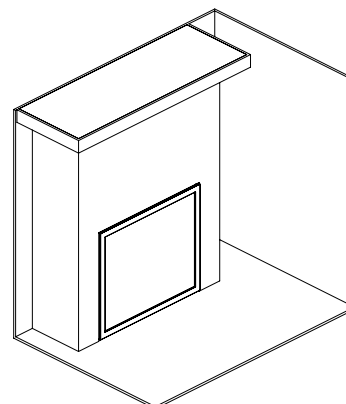

Figure 38:
Valance Iso View

Cool Surface System Framing

Framing Option 4: Bezel

The included bezel may be desired to accentuate the CSS outlet. This installation will also cover the edge of the finishing material at the cutout. Construct the framing in a way that provides a 48 inch (1219mm) by 3 inch (76mm) cutout to mount the bezel. The top of the cutout must be 1 1/2" from the top of the chase. It is essential that these dimensions are followed and not to deviated from them when using combustibile materials inside the chase (see Figure 39).

Note: If you wish to construct a similar cutout part way up a tall wall then it is essential to build a false ceiling inside the chase at the desired height to direct the rising heat out of the gap.

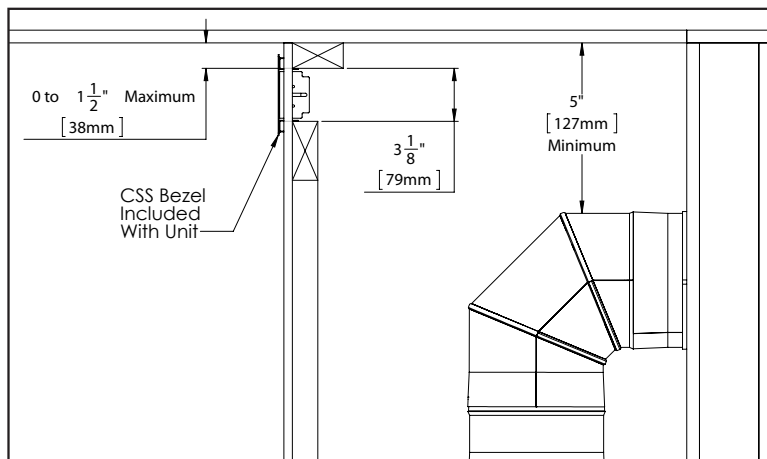

Figure 39: Option 3 Bezel

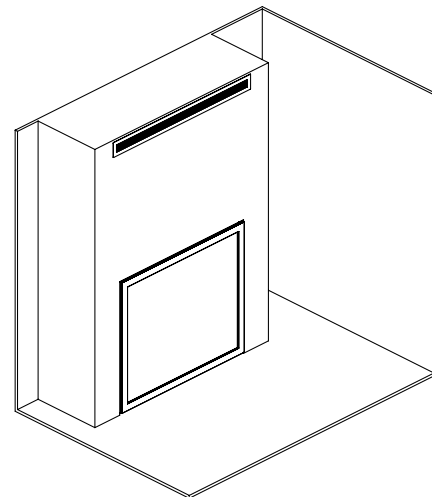

Figure 40: Bezel Iso View

Optional: False Ceiling

If your ceiling dimension is greater than the minimum (See figure 34) You may want the CSS air discharge lower on the wall. This false ceiling is required to properly evacuate heat from the chase. (See Figure 41).

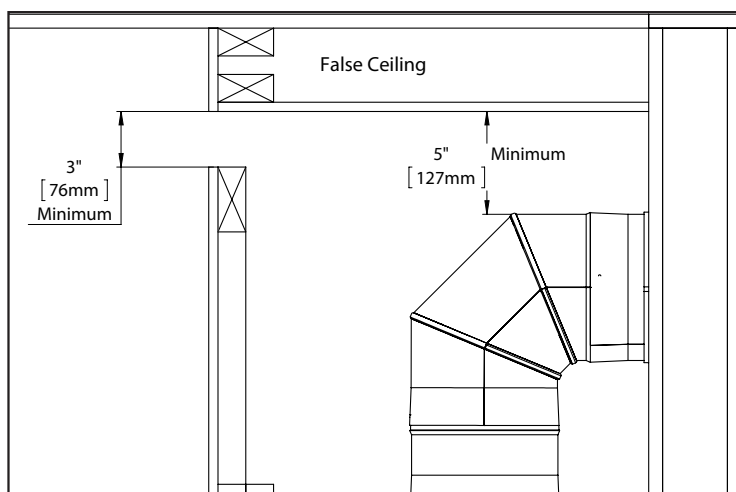

Figure 41: False Ceiling

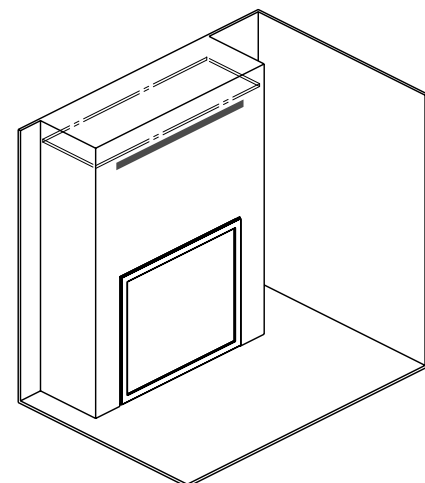

Figure 42: False Ceiling Iso View