

City Series CST60E Gas Fireplace

MODEL	CST60E-NG	CST60E-LP
Fuel Type	Natural Gas	Propane
Minimum Supply Pressure	5" W.C. (1.25 kPa)	11" W.C. (2.73 kPa)
Manifold Pressure - High	3.8" W.C. (0.94 kPa)	10.5" W.C. (2.62 kPa)
Manifold Pressure - Low	1.1" W.C. (0.27 kPa)	2.9" W.C. (0.72 kPa)
Orifice Size -Altitude 0-4500 ft	# 32 DMS	# 50 DMS
Minimum Input Altitude 0-4500 ft. (0-1372m)	21,000Btu/h (6.15 kW)	19,500 Btu/h (5.71 kW)
Maximum Input Altitude 0-4500 ft. (0-1372m)	39,000 Btu/h (11.42 kW)	36,000 Btu/h (10.54 kW)
Vent Sizing (non Power Vent)	5" Inner /8" Outer	5" Inner /8" Outer
CSA P.4.1.	60.21%	62.48%

Note: This unit comes with a 5" (127 mm) inner and 8" (203 mm) outer collar which must be reduced to 4" x 6-5/8" (102 mm x 168 mm) in all applications when installed as a power vent.



CST60E Dimensions

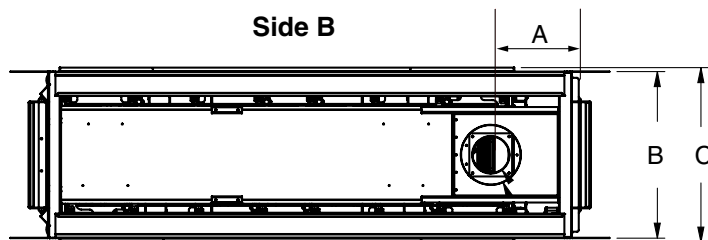

Side A

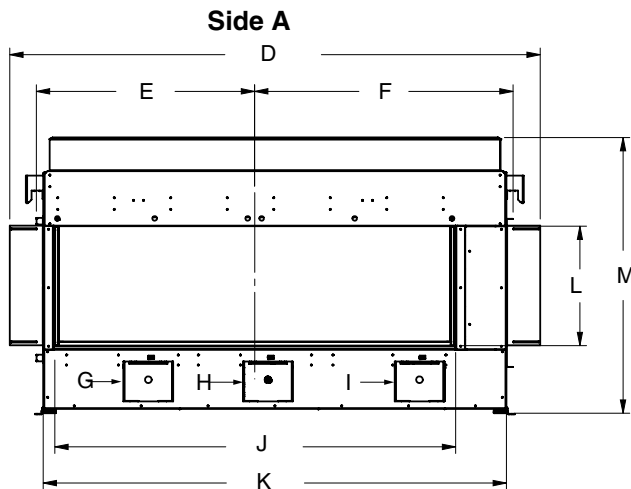
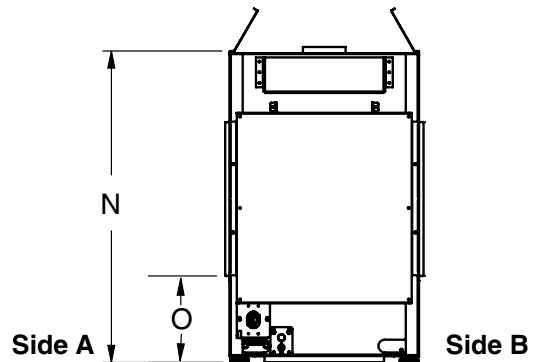

Item	Description	Measurement
A	Exhaust center to stand-off	12-11/16" (323 mm)
B	Unit body depth	22-3/16" (564 mm)
C	Width (lip to lip)	23-1/4" (591 mm)
D	nailing strip	79-1/13" (2009 mm)
E	Glass center to standoff	32-13/16" (833 mm)
F	Glass center to standoff	38-7/8" (987 mm)
G	Gas connection	N/A
H	Aeration adjustment	N/A

Item	Description	Measurement
I	Electrical	N/A
J	Viewing opening width	60-5/16" (1532 mm)
K	Unit body width	69-11/16" (1770 mm)
L	Viewing opening height	18" (457 mm)
M	Unit height	41-1/2" (1054 mm)
N	Unit body height	36-1/2" (927 mm)
O	Unit base to bottom opening	10-1/8" (257 mm)

- NOTES**
- Height dimension is taken with leveling legs fully inserted and may vary depending on the height of the leveling legs when unscrewed or extended.
 - All pictures/diagrams shown throughout this manual are for illustration purposes only. Actual product may vary due to enhancements.
 - Dimensions will appear as (inches)" / (metric) mm throughout this manual. The inches are rounded to the nearest 1/16" when converted.

Gas Connection - Bottom of Unit

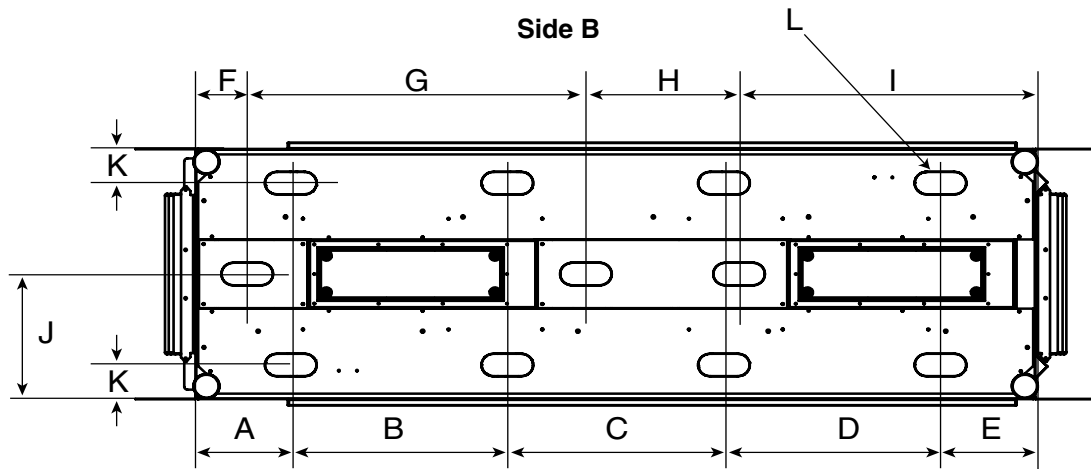

Side A

A	7-15/16" (201 mm)
B	18" (457 mm)
C	18" (457 mm)
D	18" (457 mm)
E	7-3/16" (199 mm)

F	4-5/16" (109 mm)
G	28-1/8" (715 mm)
H	12-3/4" (323 mm)
I	24 9/16" (624 mm)
J	11-1/8" (282 mm)

K	3-1/6" (77 mm)
L	11 knockouts total, each 2" (51 mm) x 13-11/16" (352 mm)

Gas/Electrical Connections - Side of Unit

Gas Connection

Electrical Connection

(Metal box supplied for all 120 volt connections.)

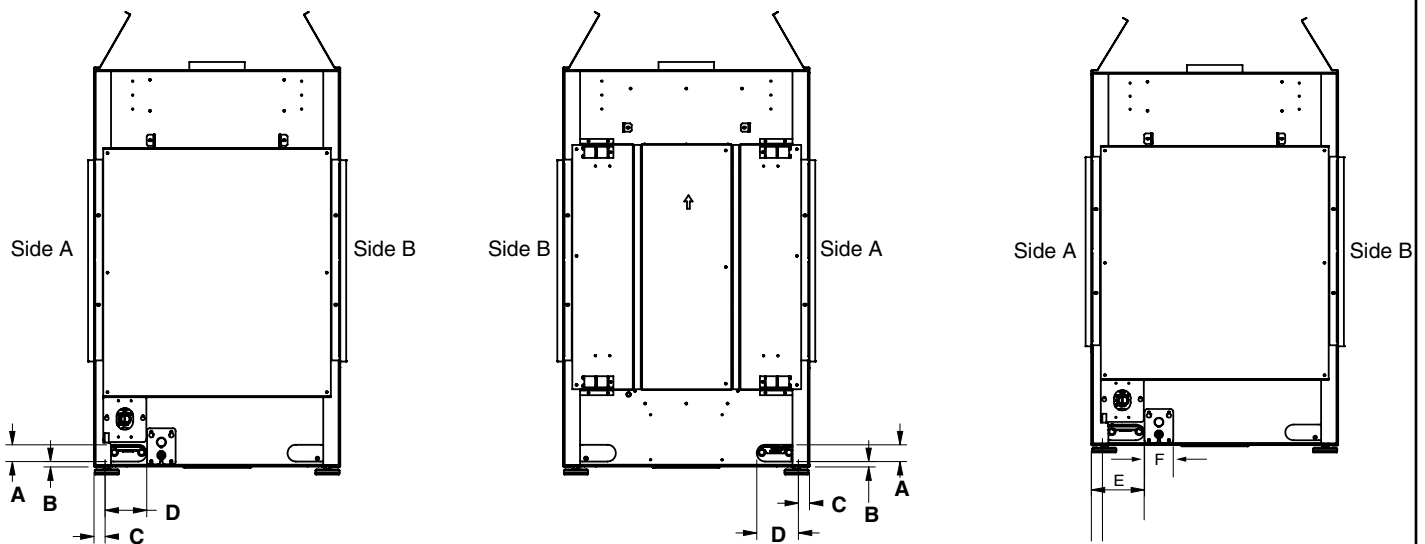

A	1-1/2" (38 mm)
B	1/2" (13 mm)

C	1" (25 mm)
D	3-3/4" (95 mm)

E	4-3/4" (121 mm)
F	2-1/2" (64 mm)

CLEARANCES - FLUSH INSTALLATION

The clearances listed below are minimum requirements for either side of this see-through fireplace, unless otherwise stated. A major cause of chimney-related fires is failure to maintain required clearances (air space) to combustible materials.

NOTES

- Flush installation is when the chase enclosure height is at a minimum of 81-1/4" (2064 mm) or greater. This would be a typical installation, with walls placed between two rooms to divide them.

Clearance	Dimension	Measured From:
A: Mantel height (min.)	**	Top of fireplace opening
B: Sidewall (on one side) min.	8" (203 mm)	Side of fireplace opening
C: Enclosure inside cavity width (min.)	71-3/4" (1822 mm)	Side wall
D: Mantel depth (max.)	**	
E: Convection air outlet	120 sq. in.*	Top, front, or side of enclosure
F: Framing depth (min.)	22-1/4" (565 mm)	From back wall to chase front
G: Opening height	18" (457 mm)	Bottom/top of fireplace opening
H: Chase enclosure (min.)	81-1/4" (2064 mm) or greater	From base of unit/floor to underside of enclosure top
I: Ceiling height (min.)	81-1/4" (2064 mm)	Measured from base of appliance
J: Convection air outlet opening offset (max.)	2" (51 mm)	Max offset from top of chase enclosure
K: Convection air outlet opening width (min.)	10" (254 mm)	
L: Convection air outlet opening height (min.)	1-1/2" (38 mm)	
M: Clearance to sprinkler head (min.)	36" (914 mm)	Perpendicular from chase grill
Hearth	0"	No hearth required

** See mantel clearances chart in the manual.

*A minimum of 120 square inches of open area, not lower than 0-2" from top of enclosure, is required for all installations.

Flue Clearances to Combustibles	
Horizontal - Top	3" (76 mm)
Horizontal - Side	2" (51 mm)
Horizontal - Bottom	2" (51 mm)
Vertical	2" (51 mm)
Passing through wall/floor/ceiling - when firestop is used.	1-1/2" (38 mm)

NOTE

- This appliance uses 5" x 8" (127 mm x 203 mm) venting for non power vent applications. For power vent applications, vent pipe must be reduced to 4" x 6-5/8" (102 mm x 168 mm).

The **HeatWave** Duct Kit has different clearance and framing requirements, check the **HeatWave** manual for details.

CAUTION

- EXTREME RISK OF FIRE** if these clearances (air space) to combustible materials are not followed.
- It is of the greatest importance that the installation of this fireplace and vent system comply with the instructions in this manual.
- The top, back, and sides of the fireplace are defined by standoffs. The metal ends of the standoffs may **NOT** be recessed into combustible construction.

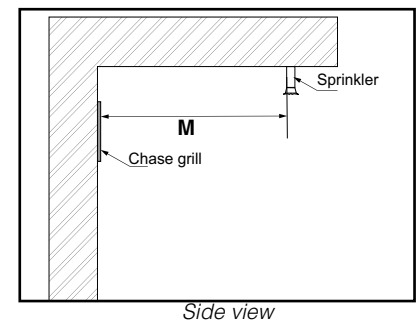
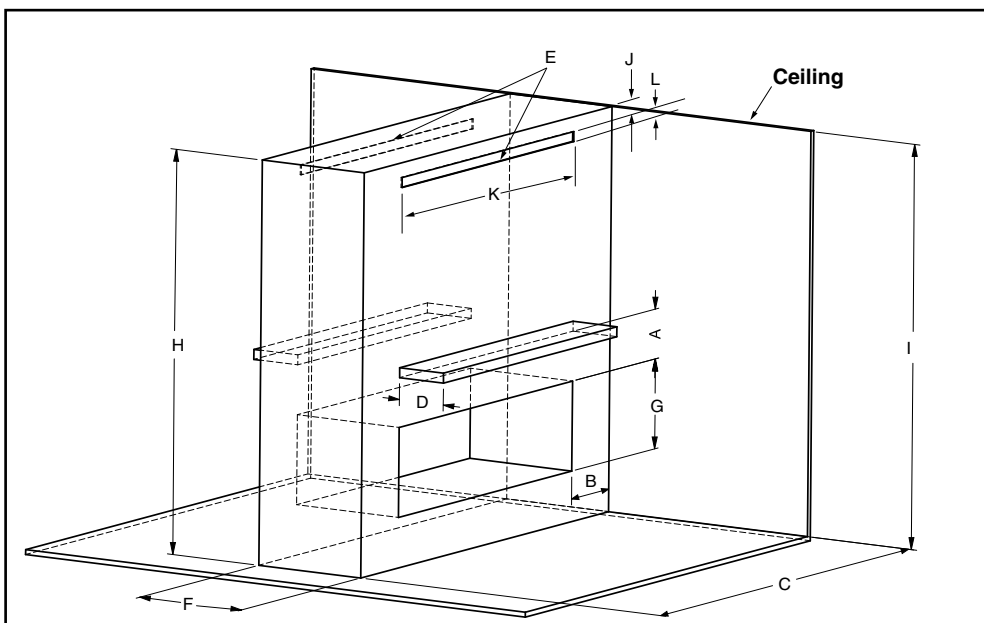

Flush Installation Examples (Ventilation Openings)

IMPORTANT

- When creating any type of ventilation opening, measures should be taken to prevent objects falling or being thrown into the ventilation opening. Mesh screen, louvers, or other protection should be used.
- If the ventilation openings are placed in two rooms (two different pressure zones), the ventilation openings must have equally split air openings to balance air flow.

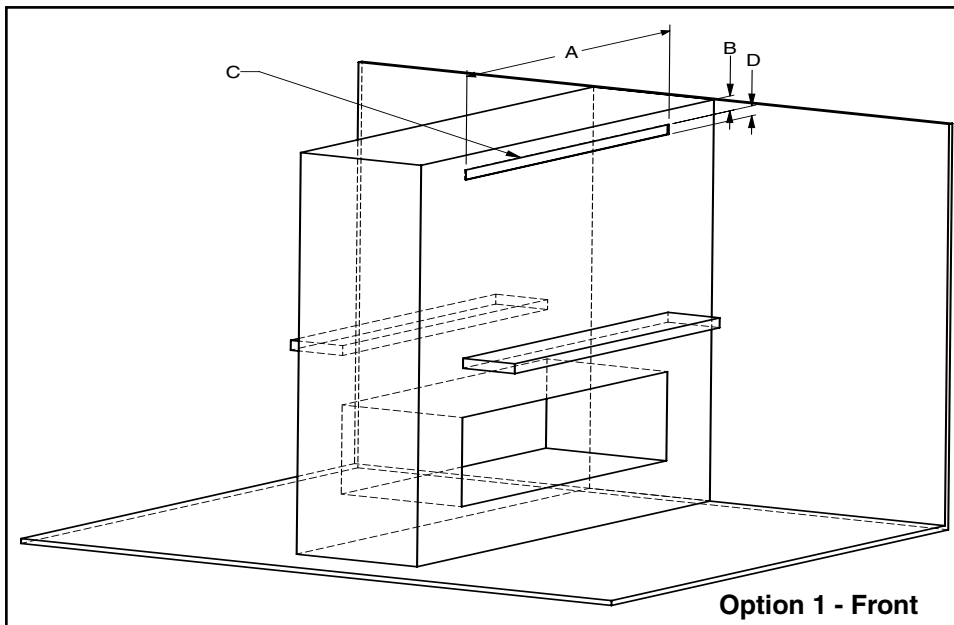

A	10" (154 mm) min.
B	2" (51 mm) max.
C	120 sq in min.
D	1-1/2" (38 mm) min.

Shown with ventilation openings on the front to meet the minimum requirement of 120 sq. in.

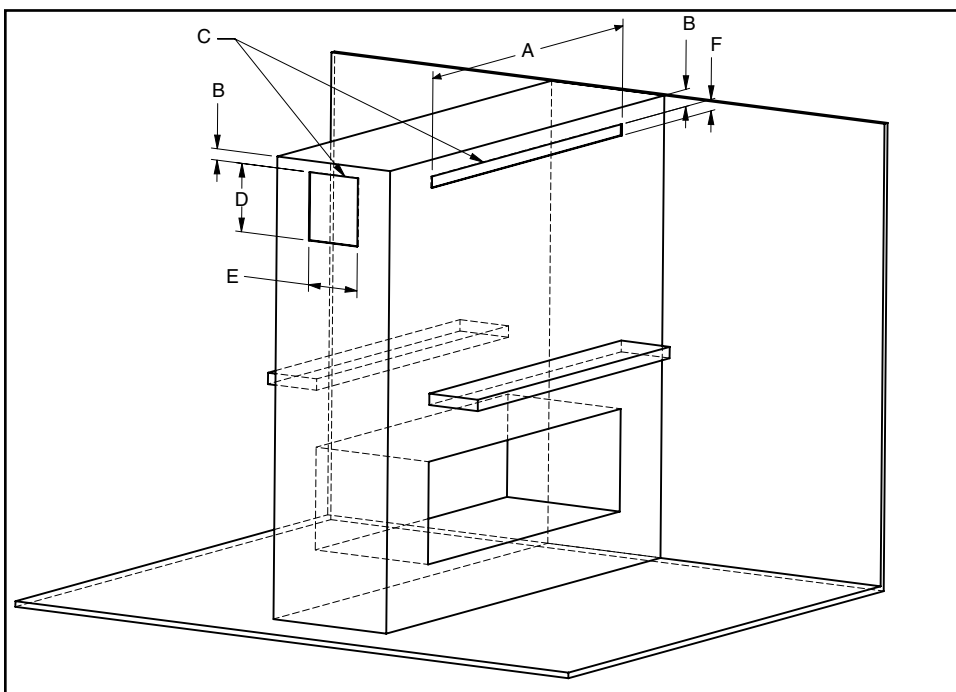

A	10" (254 mm) min.
B	2" (51 mm) max.
C	120 sq. in. min.
D	4" (102 mm) min.
E	10" (254 mm) min.
F	1-1/2" (38 mm) min.

Shown with ventilation openings on side and front to meet the minimum requirement of 120 sq. in.

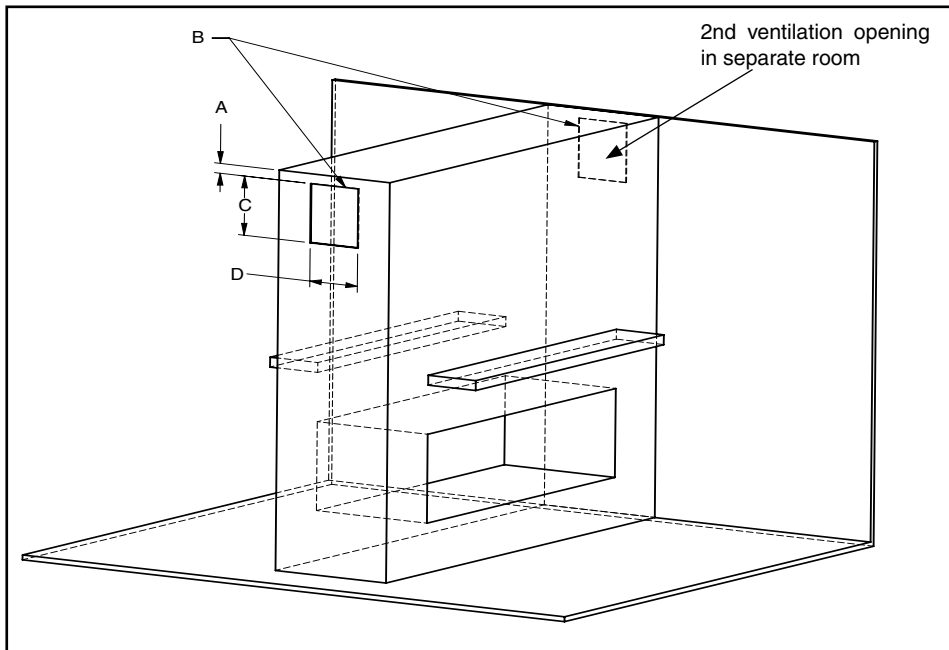

A	2" (0 - 51 mm) max.
B	120 sq. in. min.
C	4" (102 mm) min.
D	10" (254 mm) min.

Option 3 - Both Sides

Shown with ventilation openings on both sides (60 sq. in.) to meet the minimum requirement of 120 sq. in. When ventilation openings are on both sides with the second opening in another room (two different pressure zones), ventilation openings must be the same size to balance air flow.

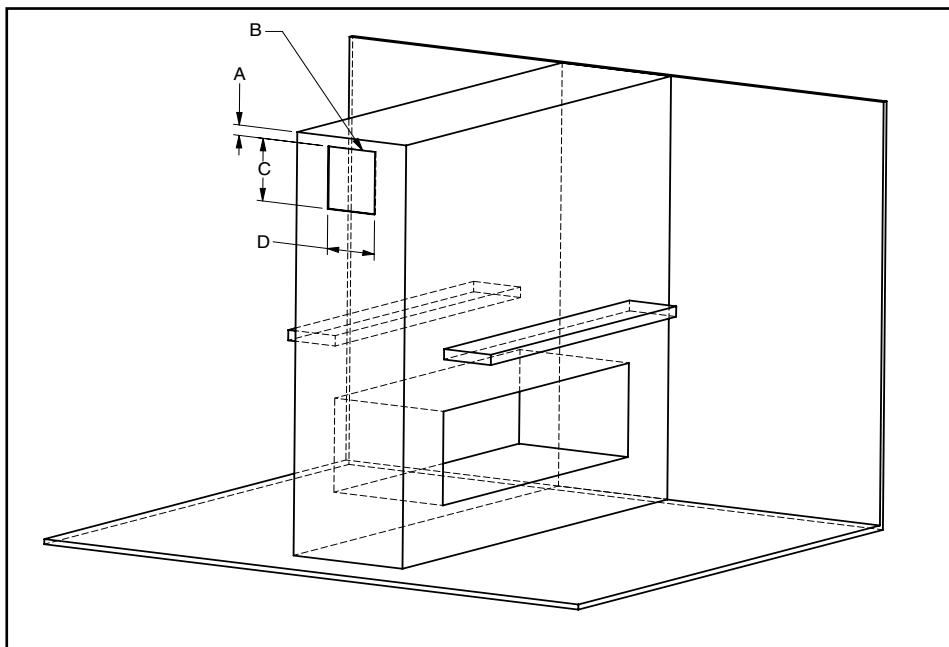

A	2" (51 mm) max.
B	120 sq. in. min.
C	4" (102 mm) min.
D	10" (254 mm) min.

Option 4 - One Side

Shown with ventilation opening on one side to meet the minimum requirement of 120 sq. in.

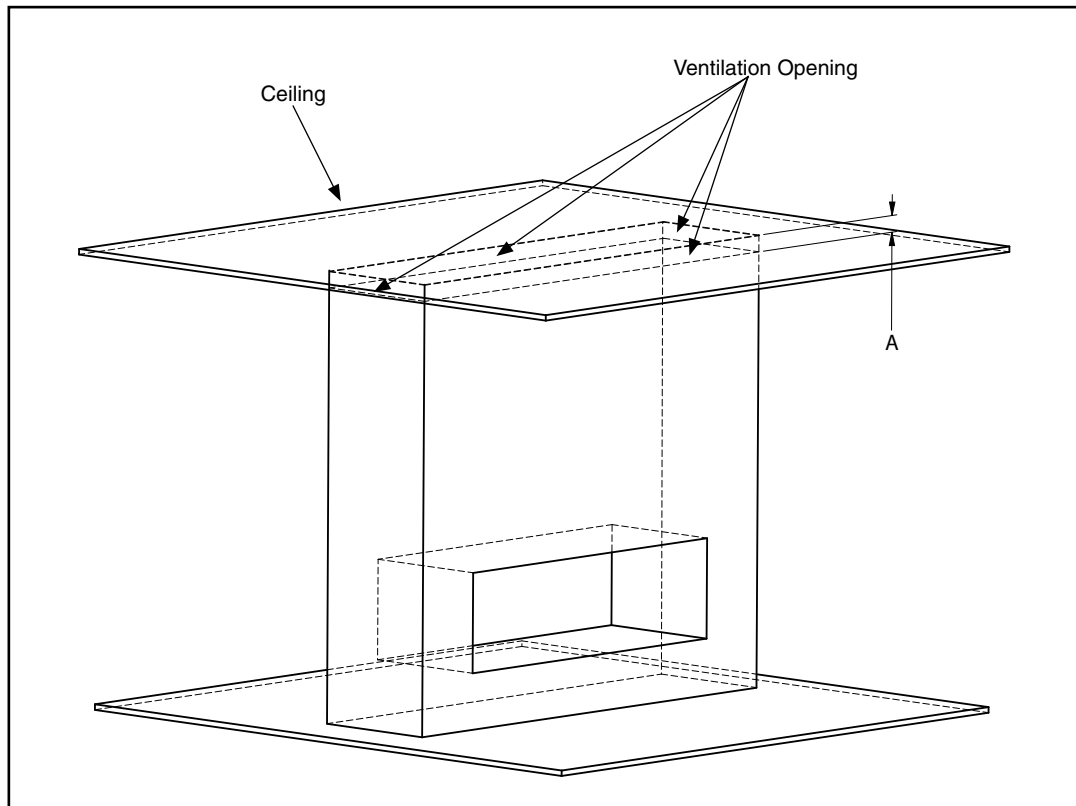

A	1-3/4" (44 mm) max.
---	---------------------

Option 5 - Reveal at Top

Shown with ventilation opening at top of enclosure to meet the minimum requirement of 120 sq. in. A minimum gap of 1-3/4" (44 mm) between the top of the enclosure and the ceiling is required with this type of ventilation opening, to equal the minimum requirement of 120 sq. in.

CLEARANCES - BENCH INSTALLATION

The clearances listed below are minimum requirements for either side of this see-through fireplace, unless otherwise noted. A major cause of chimney-related fires is failure to maintain required clearances (air space) to combustible materials. It is of the greatest importance that this fireplace and vent system are installed in accordance with the instructions in this manual.

NOTE • Bench installation is when the chase enclosure height is at a minimum of 52" (1321 mm) to a maximum of 81-1/4" (2064 mm). If the bench installation is completed at the minimum height, a shelf, counter top, or other finish can be installed.

Clearance	Dimension	Measured From:
A: Mantel height (min.)	**	Top of fireplace opening
B: Sidewall (on one side) min.	8" (203 mm)	Side of fireplace opening
C: Enclosure inside cavity width (min.)	71-3/4" (1822 mm)	Side wall
D: Mantel depth (max.)	**	
E: Convection air outlet (min.)	180 sq. in.	Top, front of enclosure
F: Framing depth (min.)	22-1/4" (565 mm)	From back wall to chase front
G: Opening height	18" (457 mm)	Bottom/top of fireplace opening
H: Chase enclosure (min.)	52" (1321 mm) to 81-1/4" (2064 mm) max.	From base of unit/floor to underside of enclosure top
I: Ceiling height (min.)	81-1/4" (2064 mm)	Measured from base of appliance
J: Convection air outlet opening offset (max.)	2" (51 mm)	Max offset from top of chase enclosure
K: Convection air outlet opening width (min.)	10" (254 mm)	
L: Convection air outlet opening height (min.)	1-1/2" (38 mm)	
M: Ceiling clearance (min.)	3" (76 mm)	Top convection air outlet only
N: Clearance to sprinkler head	36" (914 mm)	Perpendicular from chase grill
Hearth	0"	No hearth required

** See mantel clearances chart in the manual.
 * For clearances greater than 81 1/4" (2064 mm), see flush installation clearances in this manual. The size of the ventilation opening is reduced from 180 sq. in. to 120 sq. in.

Flue Clearances to Combustibles	
Horizontal - Top	3" (76 mm)
Horizontal - Side	2" (51 mm)
Horizontal - Bottom	2" (51 mm)
Vertical	2" (51 mm)
Passing through wall/floor/ceiling - when firestop is used.	1-1/2" (38 mm)

NOTES

- This appliance uses 5" x 8" (127 mm x 203 mm) venting for non power vent applications. For power vent applications, vent pipe must be reduced to 4" x 6 5/8" (102 mm x 168 mm).
- HeatWave not permitted in bench applications.

*A minimum of 120 square inches of open area, not lower than 0-2" (51 mm) from top of enclosure, is required for all installations.

CAUTION

- **EXTREME RISK OF FIRE** if these clearances (air space) to combustible materials are not adhered to. It is of greatest importance that this fireplace and vent system are installed in accordance with the instructions in this manual.
- The top, back, and sides of the fireplace are defined by standoffs. The metal ends of the standoff may **NOT** be recessed into combustible construction.

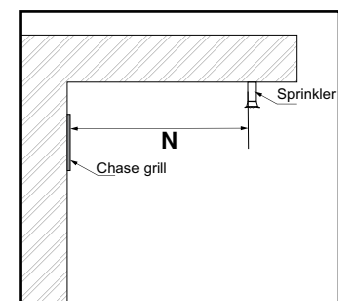
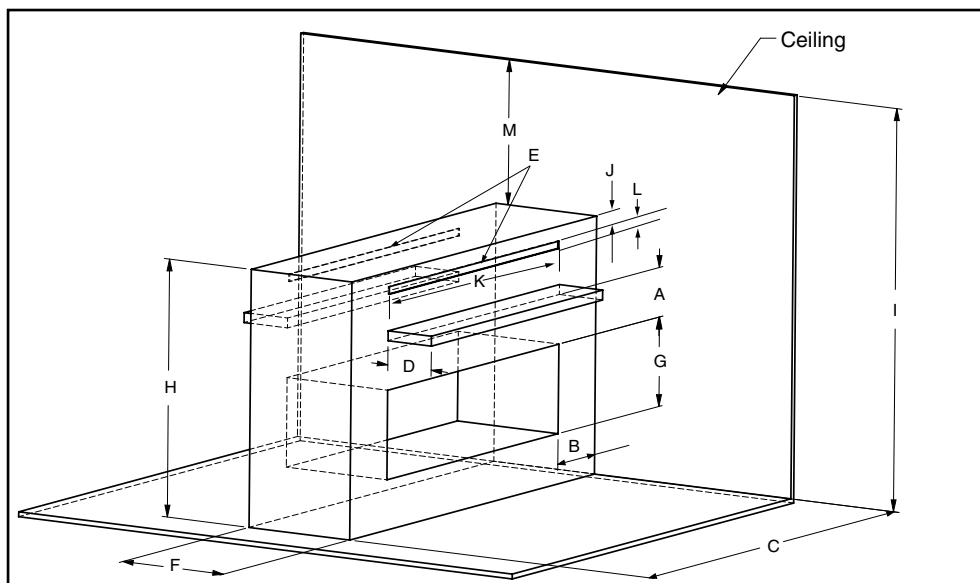

Side view

Bench Installation Examples (Ventilation Openings)

IMPORTANT

- When creating any type of ventilation opening, measures should be taken to prevent objects falling or being thrown into it. Mesh screen, louvers, or other protection should be used.
- **If the ventilation openings are placed in two rooms (two different pressure zones), the ventilation openings must have equally split air openings to balance air flow.

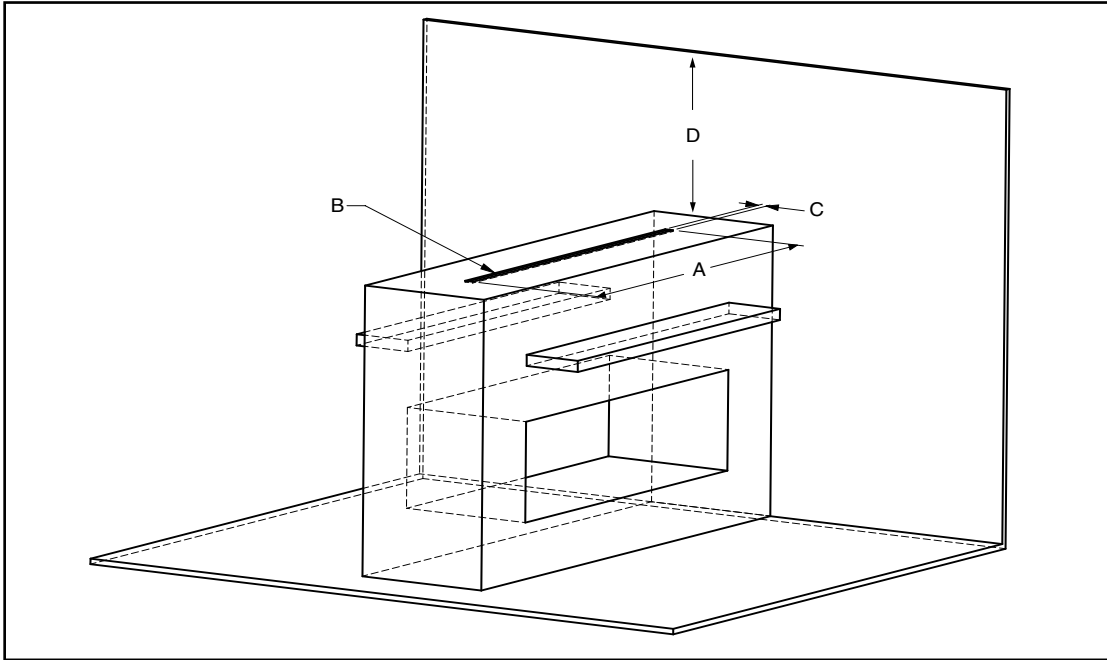

Option 1 - Top

Shown with ventilation opening on top of the enclosure to meet the minimum requirement of 180 sq. in.

A	10" (254 mm) min.
B	180 sq. in. min.
C	1-1/2" (38 mm) min.
D	3" (77 mm) min.

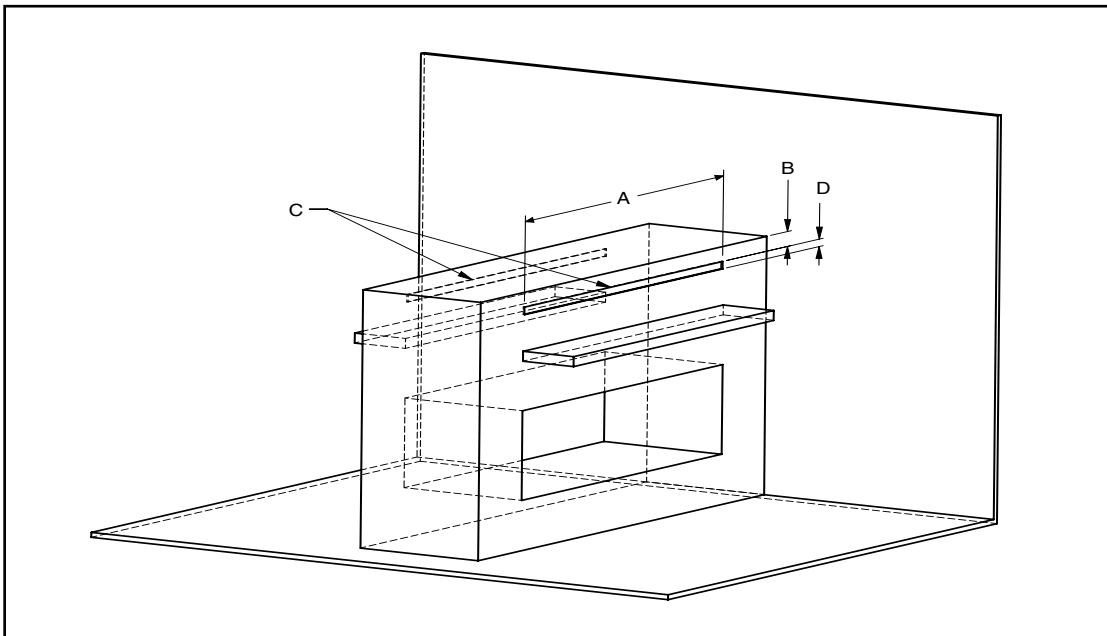

Option 2 - Front and Back

Shown with ventilation openings on the front and back of the enclosure to meet the minimum requirement of 180 sq. in.

A	10" (51 mm) min
B	2" (51 mm) max.
C	90 sq. in. front and back
D	1-1/2" (38 mm) min.

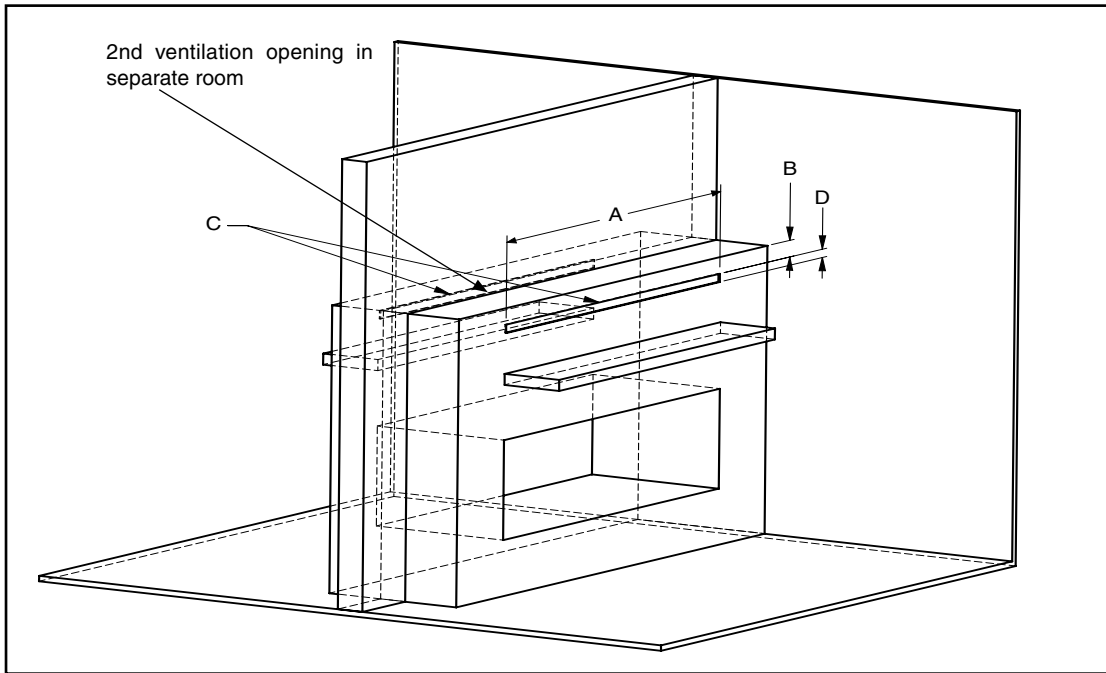

A	10" (51 mm) min
B	2" (51 mm) max.
C	90 sq. in. front and back
D	1-1/2" (38 mm) min.

****Option 3 - Front/Back Wall with second ventilation in separate room**

Shown with ventilation opening on front and back to meet the minimum requirement of 180 sq. in. When on the front and back with second ventilation located in another room (two different pressure zones), ventilation openings must be the same size and have equally split air openings to balance air flow.

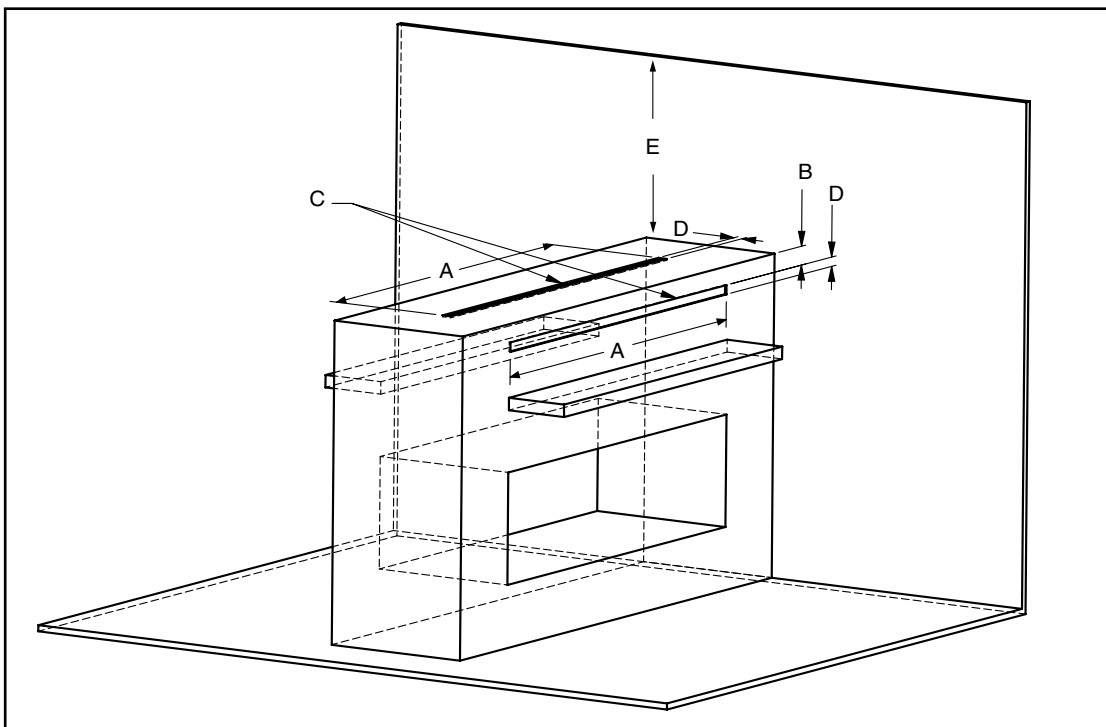

A	10" (254 mm) min.
B	2" (51 mm) min.
C	180 sq. in. min.
D	1-1/2" (38 mm) min.
E	3" (77 mm) min.

Option 4 - Top and Front

Shown with ventilation opening on top and front (90 sq. in. each) to meet the minimum requirement of 180 sq. in.

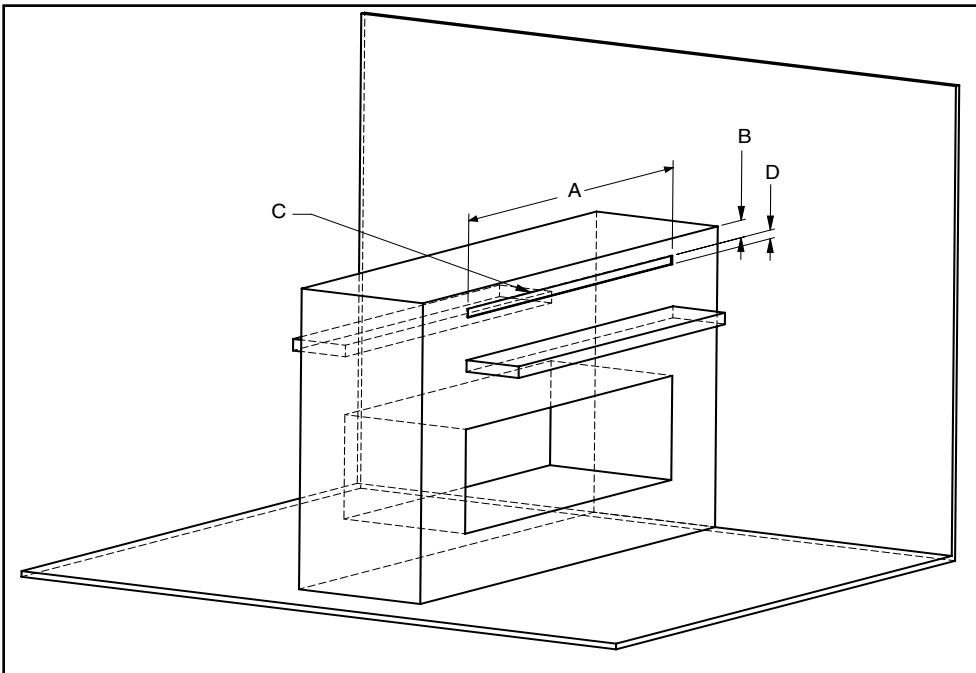

Option 5 - Front

Shown with ventilation opening on the front to meet the minimum requirement of 180 sq. in.

A	10" (254 mm) min.
B	2" (51 mm) min.
C	180 sq. in min.
D	1-1/2" (38 mm) min.

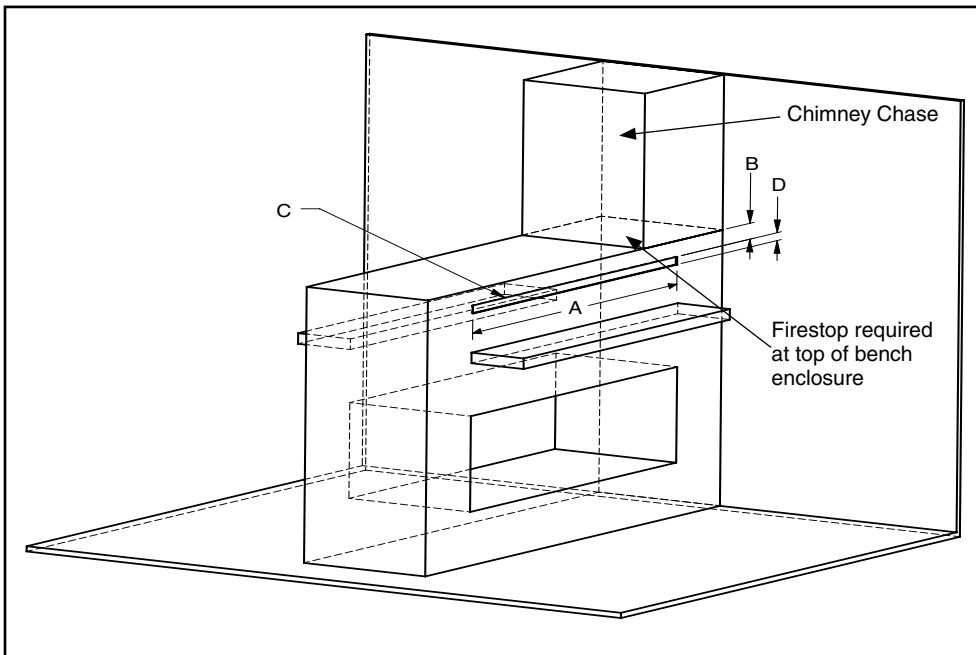

Option 6 - Chimney Chase

Shown with ventilation opening on the front with a chimney chase to meet the minimum requirement of 180 sq. in.

A	10" (254 mm) min.
B	2" (51 mm) min.
C	180 sq. in min.
D	1-1/2" (38 mm) min.

IMPORTANT

- The chimney chase must be sealed with a firestop to prevent heat from escaping into the chimney chase enclosure. All heat must exit through the ventilation openings.

MANTEL CLEARANCES

Combustible mantel clearances from top of front facing are shown in the diagram below.

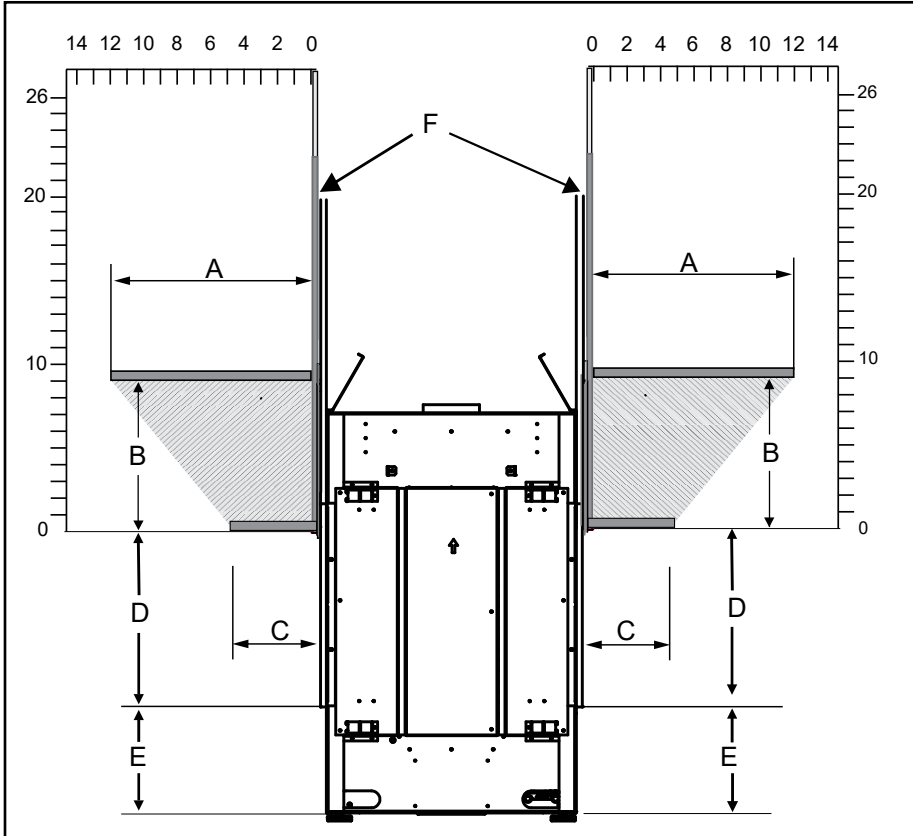

A	12" (305 mm) maximum
B	9" (229 mm)
C	5-1/4" (133 mm) maximum
D	18-1/16" (459 mm)
E	10-1/4" (260 mm) - from base of unit to bottom of fireplace
F	1/2" Drywall, wood, wood panel, etc.

MANTEL LEG CLEARANCES

Combustible mantel leg clearances as per diagram.

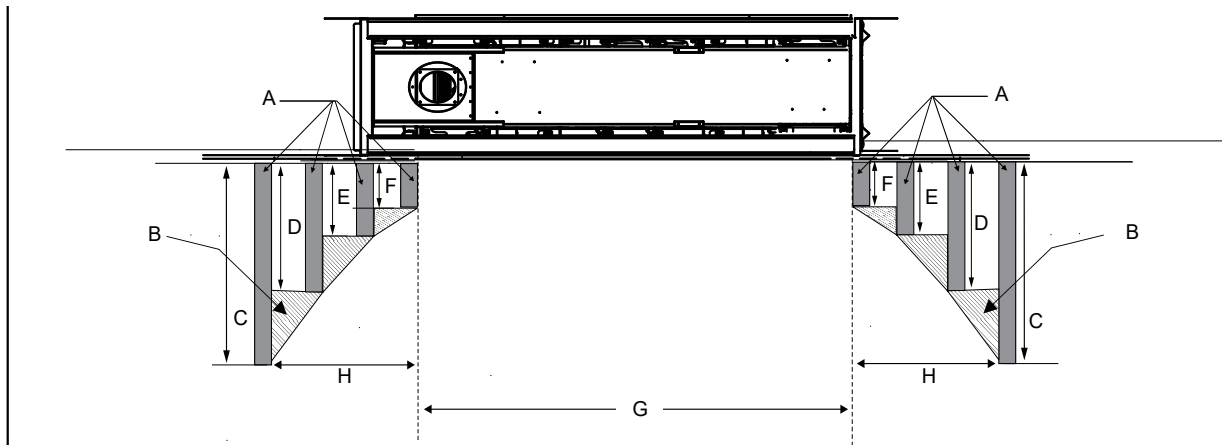

A	Mantel Leg
B	Allowable mantel leg projection
C	12" (305 mm)
D	9" (229 mm)

E	7" (179 mm)
F	5" (127 mm)
G	60-5/16" (1532 mm) - measured from side lip finishing
H	10-1/4" (260 mm)

NOTE • One side shown. Clearances are the same on the other side.

FRAMING

NOTE • Framing may be constructed of combustible material (i.e. 2 x 4 or 2 x 6) and does not require steel studs.

Framing Dimensions	Description	CST60E
A	Framing height	For 2" x 4": 45-1/8" (1146 mm) For 2" x 6": 52" (1321 mm)
B*	Framing width	71-3/4" (1822 mm)
C	Finished floor or hearth	
D	Framing depth	22-1/4" (565 mm)
E	Minimum height to combustibles	BENCH: 52" (1321 mm) FLUSH: 81-1/4" (2064 mm)
F	Minimum height to flue centerline measured from base of appliance	46-1/4" (1175 mm)

*The lift handles add approximately 4 inches to the width of the appliance. If the appliance will be lifted off the ground and slid into the framed opening, we suggest changing the framing width from 71-3/4" (1822 mm) to 75-11/16" (1922 mm) to allow the appliance to slide into position with the handles on, or creating a platform in front of the framed opening where the lift handles can be removed prior to installation. If the framing is raised off the ground, you can install it after the appliance is in place with handles removed to maintain the framing width of 71-3/4" (1822 mm). Ensure that the wood base for the appliance is strong enough to support its shipping weight of 556 pounds (252 kg).

NOTES

- Framing may be constructed of combustible material (i.e. 2 x 4 or 2 x 6) and does not require steel studs.
- This appliance must be installed on a solid surface such as a plywood floor which must be the full width and depth of the appliance.
- A combined minimum of 180 square inches of open area for the bench installation and 120 square inches for the flush installation is required for the convection air outlet to cool the enclosure. Ensure clearances for convection air outlets are met.
- See clearances in this manual for different ways to achieve this.

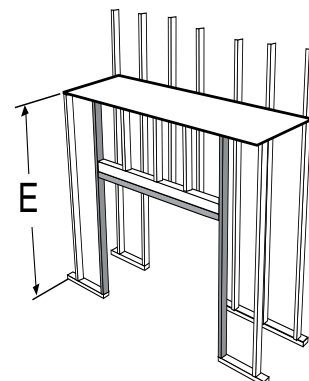
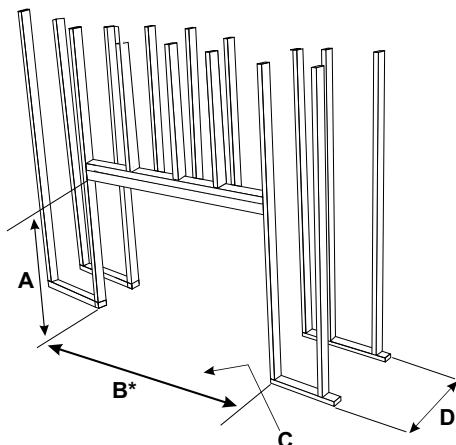
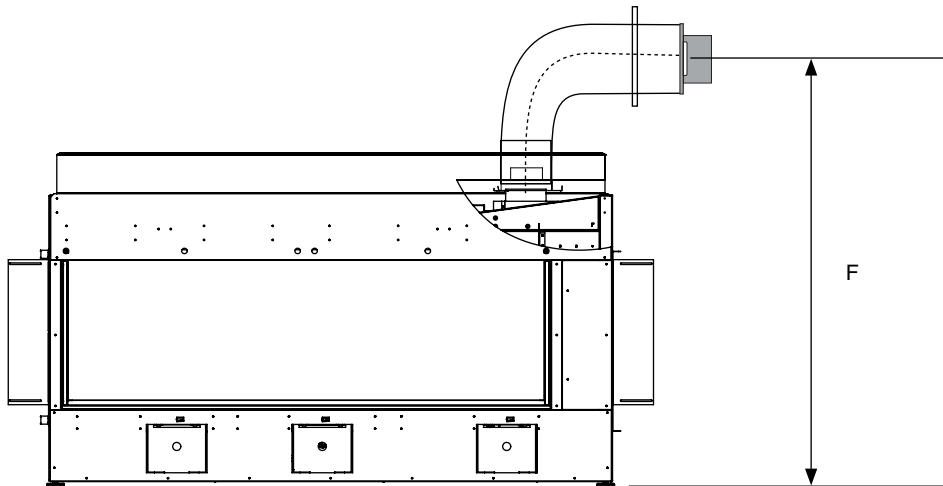

CHASE VENT INSTALLATION

NOTE

• This chase vent is only used when accommodating a 180 sq. in. ventilation opening.

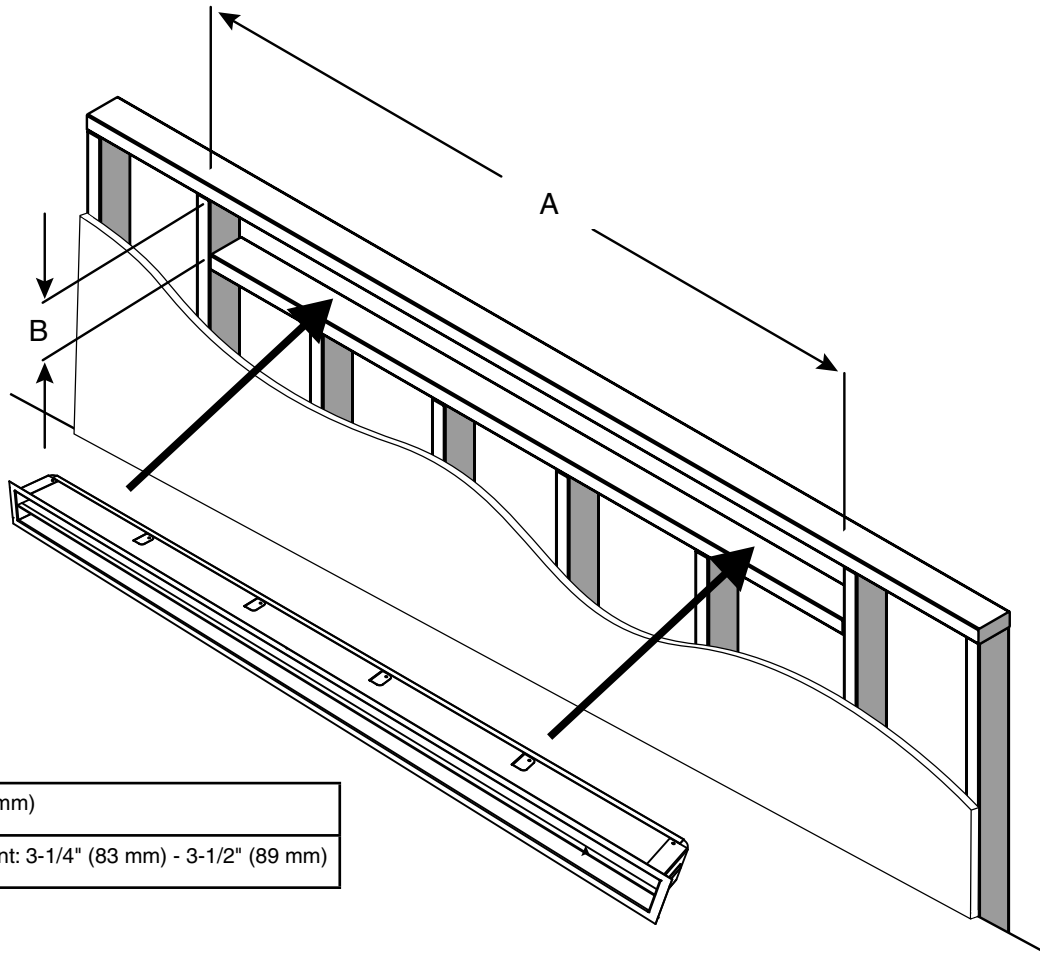

A	60-1/2" (1537 mm)
B	Opening for vent: 3-1/4" (83 mm) - 3-1/2" (89 mm)

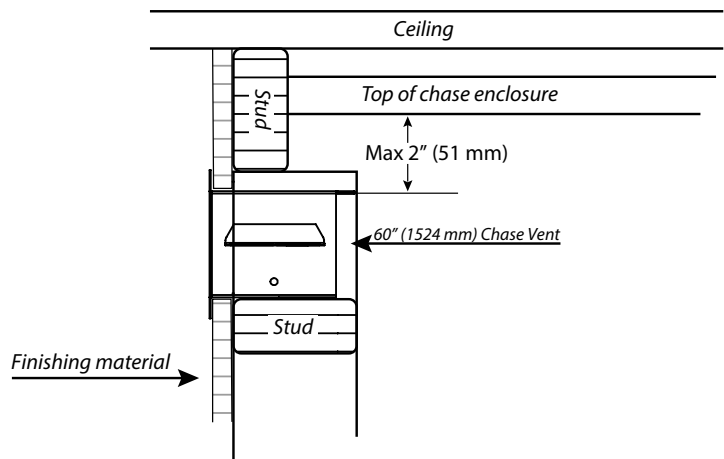
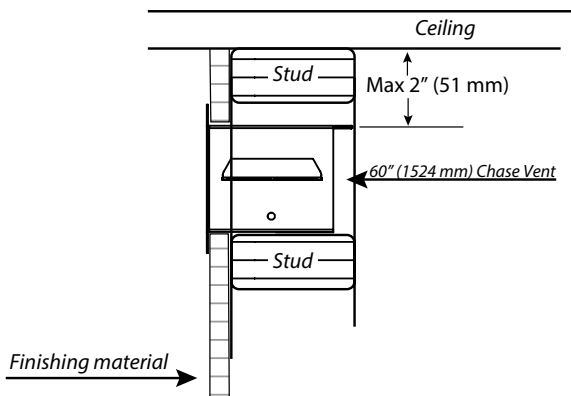

CHASE ENCLOSURE

When choosing to install the ventilation openings from the front or sides, the top of the ventilation opening cannot be any lower than 0-2" (51mm) from the top of the chase enclosure for all installations.

The minimum height of the enclosure from the base of the appliance is 52" (1321 mm) for the bench installation and 81-1/4" (2064 mm) for the flush installation.

A minimum 180 sq. in. (bench) or 120 sq. in. (flush) opening in the enclosure is required to maintain safe operating temperatures. This can be achieved in a number of ways, including those shown in the examples in this manual.

IMPORTANT

- **Exterior wall/alcove enclosure** : when installing into an exterior cavity or alcove enclosure (ceiling, back, and sides) regardless of where the appliance is placed within the home, drywall or other materials such as plywood, wood studs, etc. are required to prevent heat from escaping above or through the enclosure (other than out the required grill / ventilation openings).
- **Internal chase** : when installing as an internal chase framing regardless of where the appliance is placed within the home, drywall or other materials such as plywood must be used on the rear wall of the chase to eliminate heat escaping into the rear wall cavity. The ceiling will also need to be finished to prevent heat escaping into floor joists, or the attic space if the chase extends to it. One of the following methods must be used to prevent the heat from escaping:
 - a. If choosing drywall, ensure that it butts up tight with no gaps.
 - b. Plywood, wood studs, etc. installed tightly with no gaps.
- This appliance was designed to allow hot air to escape through the chase enclosure ventilation/grill openings. If hot air is trapped as a result of it escaping through joints, crevasses, open studs, or other openings within the enclosure, this will change the clearances within the enclosure, causing it to overheat. It is vital that all hot air within the enclosure exit through the ventilation openings only. Ensure that the ventilation openings are constructed to prevent debris from falling into the enclosure.
- DO NOT cover or place objects in front of the ventilation opening air outlet(s).

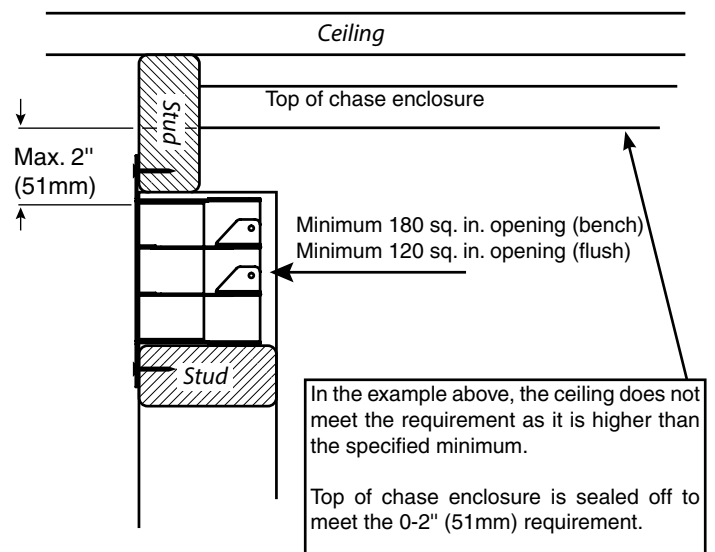
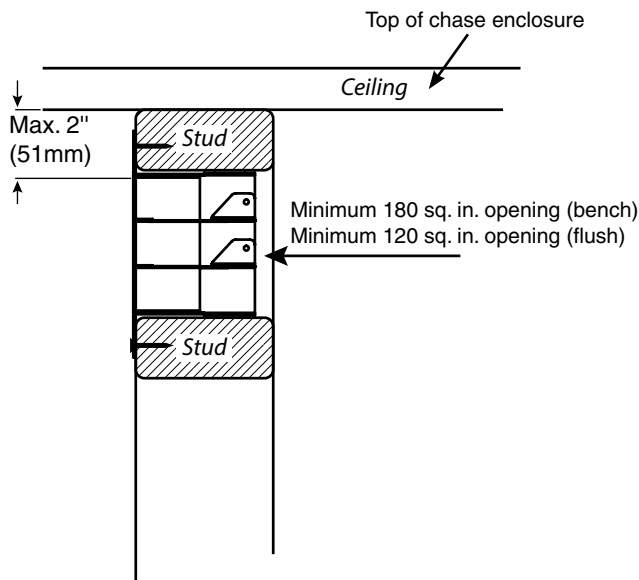

TYPICAL INSTALLATIONS

Flush TV Install

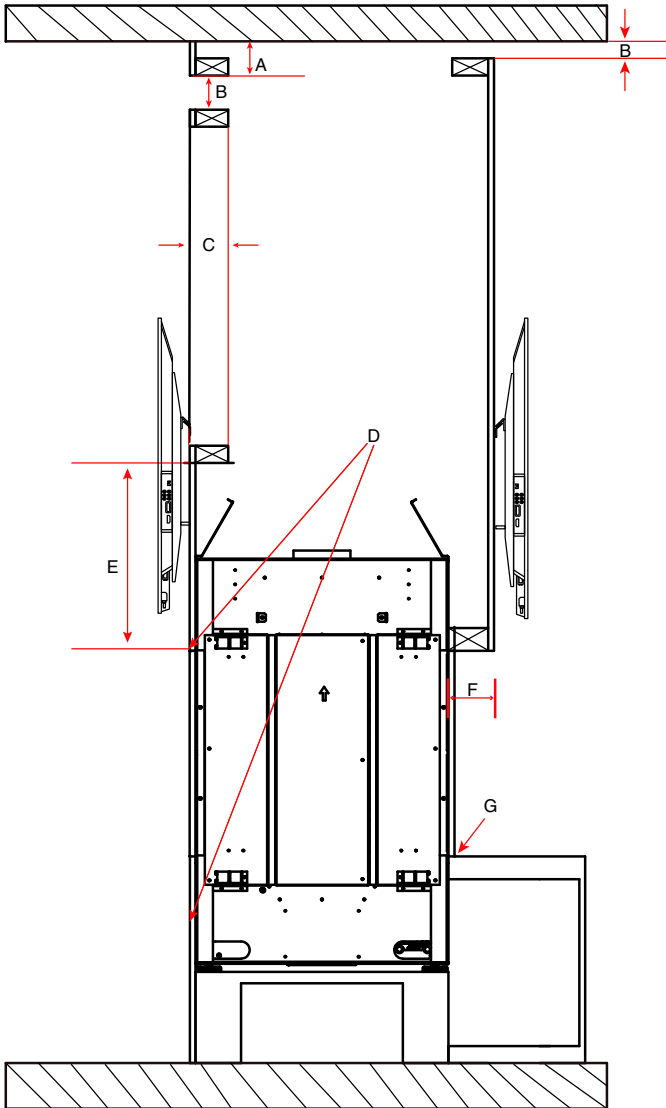

A	Max. 2" (51 mm) to top of enclosure
B	Min. 1-1/2" (38 mm) Chase vent min. open area: 180 sq. in. Bench Install 120 sq. in. Flush Install
C	Max. 5-1/2" (140 mm) (2 x 6 stud) See E for corresponding min. height requirements.
D	Screws must not penetrate unit more than 1/2" (25 mm). Adhere to "No Screw" zones painted on unit; glue is an acceptable alternative.
E	Min. 16-1/2" (419 mm) with 2 x 4 - dimension C Min. 23-3/8" (594 mm) with 2 x 6 dimension C
F	Maximum 5-1/4" (133 mm)
G	Bottom of fireplace opening - combustible hearth shown.

NOTE • A recess may be used on both sides if the clearance requirements shown above are adhered to.

Recessed TV Install

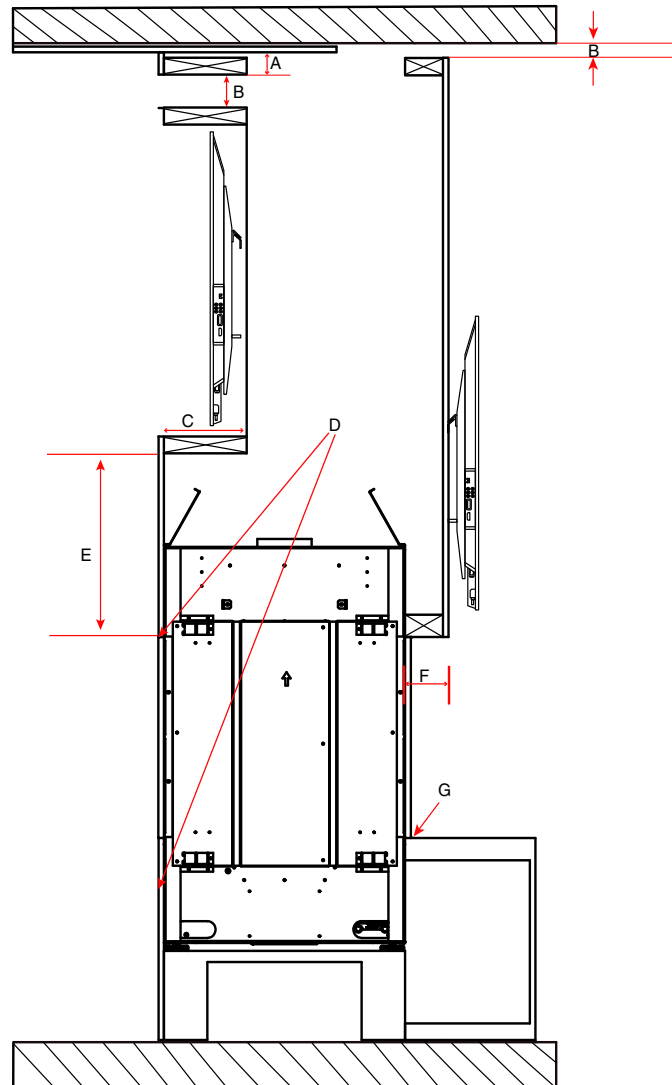

A	Max. 2" (51 mm) to top of enclosure
B	Min. 1-1/2" (38 mm) Chase vent min. open area: 180 sq. in. (bench Install) 120 sq. in. (flush Install)
C	Max.: 5-1/2" (140 mm) 2 x 6 stud. See E for corresponding min. height requirements.
D	Screws must not penetrate unit more than 1/2" (25 mm). Adhere to "No Screw" zones painted on unit. Glue is an acceptable alternative.
E	Min. 16-1/2" (419 mm) with 2 x 4 - dimension C Min. 23 3/8" (594 mm) with 2 x 6 - dimension C
F	5-1/4" (140 mm) maximum
G	Bottom of fireplace opening - combustible hearth shown.

NOTE

- A recess may be used on both sides if the clearance requirements shown above are adhered to.
- The TV mounting bracket cannot be secured directly to the appliance-it must be secured to the framing. The TV depicted in the image above may require a higher placing, depending on the style of the TV and the mounting bracket used.

CHASE VENTING

NOTE

- This chase vent is only used when accommodating a 180 sq. in. ventilation opening.

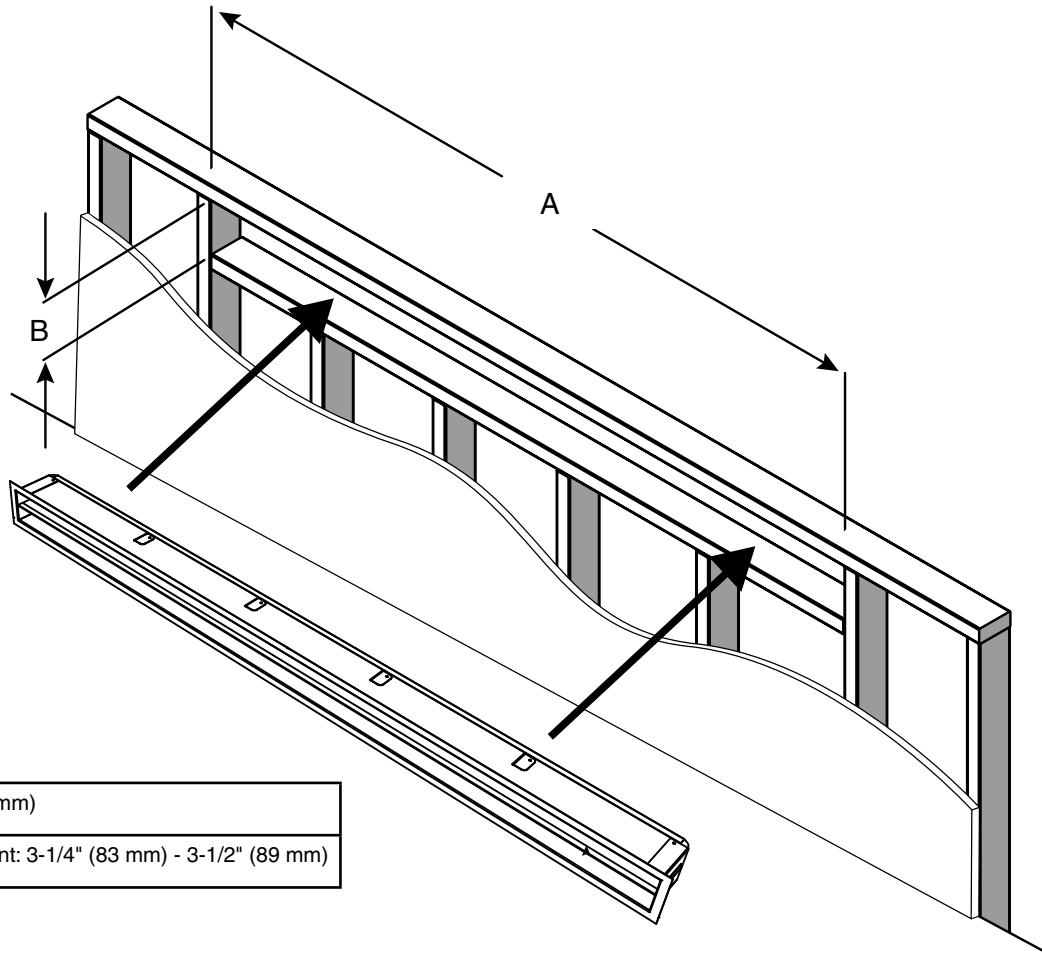

A	60-1/2" (1537 mm)
B	Opening for vent: 3-1/4" (83 mm) - 3-1/2" (89 mm)

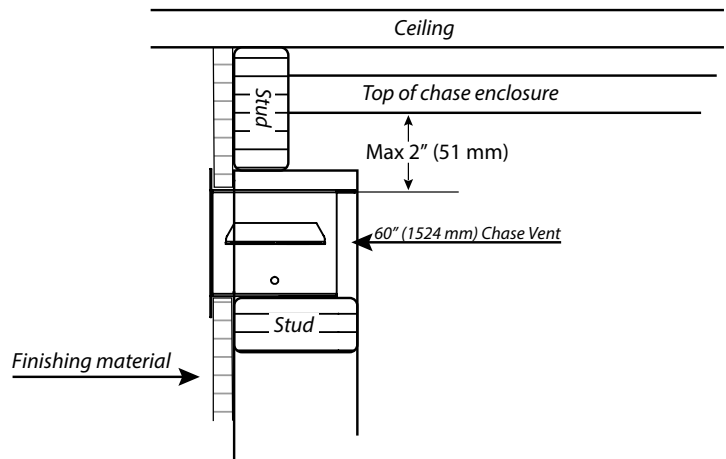
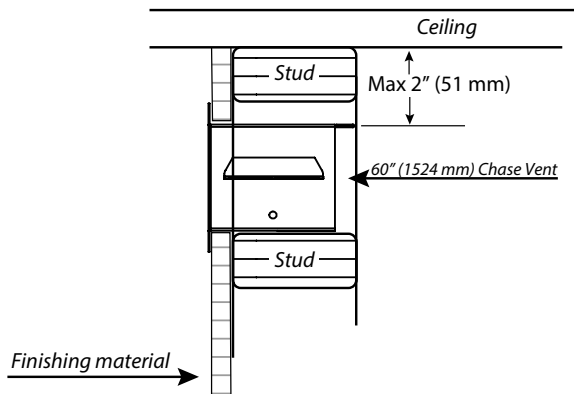

VENTING INTRODUCTION - NON-POWER VENT

The CST60E uses the "balanced flue" technology co-axial system. The inner liner vents products of combustion to the outside while the outer liner draws outside combustion air into the combustion chamber, thereby eliminating the need to use heated room air for combustion and losing warm room air up the chimney.

NOTE: These flue pipes must not be connected to any other appliance.

The gas appliance and vent system must be vented directly to the outside of the building, and never be attached to a chimney serving a separate solid fuel or gas burning appliance. Each direct vent gas appliance must use its own separate vent system. Common vent systems are prohibited.

Venting Arrangement for Horizontal Terminations (Rigid and Flex)

The diagram shows all allowable combinations of vertical runs with horizontal terminations, using one 90° elbow (two 45° elbows equal one 90° elbow).

- NOTES**
- Must use optional rigid pipe adapter (part# 770-994) when using rigid pipe venting systems.
 - For horizontal terminations, the Regency direct vent flex system may be used for installations with a maximum continuous vent length of up to 10 feet. If longer runs are required, rigid pipe must be used.

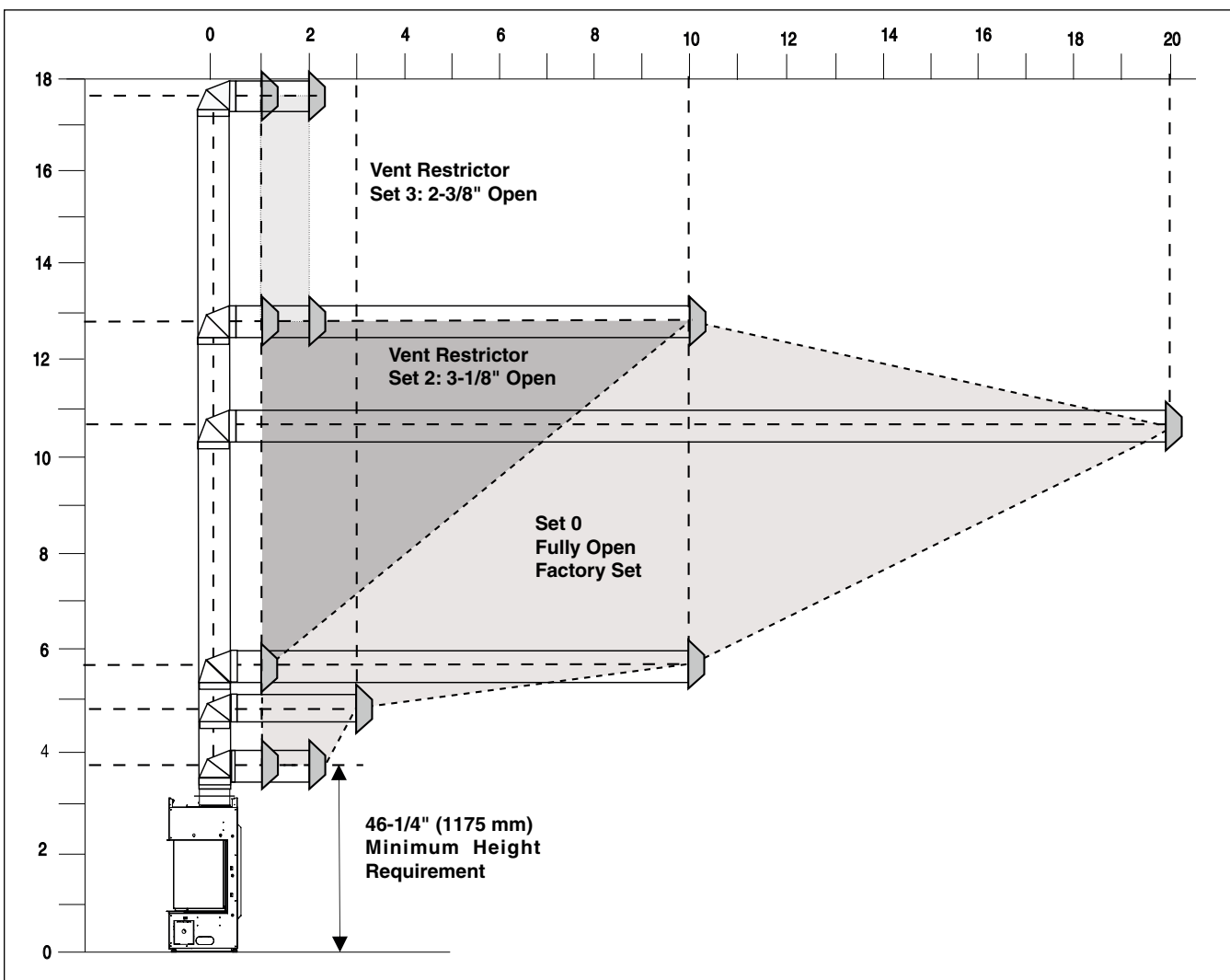

VENT RESTRICTOR SETTING:

Vent restrictor factory set at Set 0.

Refer to the "Vent Restrictor Position" section for details on how to change the vent restrictor from the factory setting of Set 0 to Set 2 if required.

- Maintain clearances to combustibles as listed in "Clearances" section
- Horizontal vent must be supported every 3 feet.
- Firestops are required at each floor level and whenever passing through a wall.
- A vent guard should be used whenever the termination is lower than the specified minimum or as per local codes.

HORIZONTAL TERMINATIONS

Flex Vent 5" x 8" (127 mm x 203 mm)

These venting systems, in combination with the CST60E Direct Vent Gas Fireplace, are tested and listed as a direct vent heater system by Intertek. The location of the termination cap must conform to the requirements in the vent terminal locations diagram in the "Exterior Vent Termination Locations" section of this manual.

Regency® Direct Vent (Flex) System Termination Kits include all the parts needed to install the CST60E using a flexible vent.

FPI Kit #	Length	Contains:
#946-615	4 Feet	1) 8" Flexible Liner (Kit length) 2) 5" Flexible Liner (Kit length) 3) Spring Spacers
#946-618	6 Feet	4) Thimble 5) AstroCap XL Termination Cap 6) Screws
#946-616	10 Feet	7) Tube of Mill Pac 8) Plated Screws 9) S.S. Screws #8 x 1-1/2" Drill Point 10) Vinyl Siding Standoff

- NOTES**
- Liner sections should be continuous without any joints or seams.
 - Only flex pipe purchased from Regency® may be used for flex installations.
 - Horizontal vent must be supported every 3 feet.
 - Regency® Direct Vent System (Flex) is only approved for horizontal terminations.
 - Flex system can only be used up to a maximum continuous vent length of 10 feet. If longer runs are required, rigid pipe must be used.

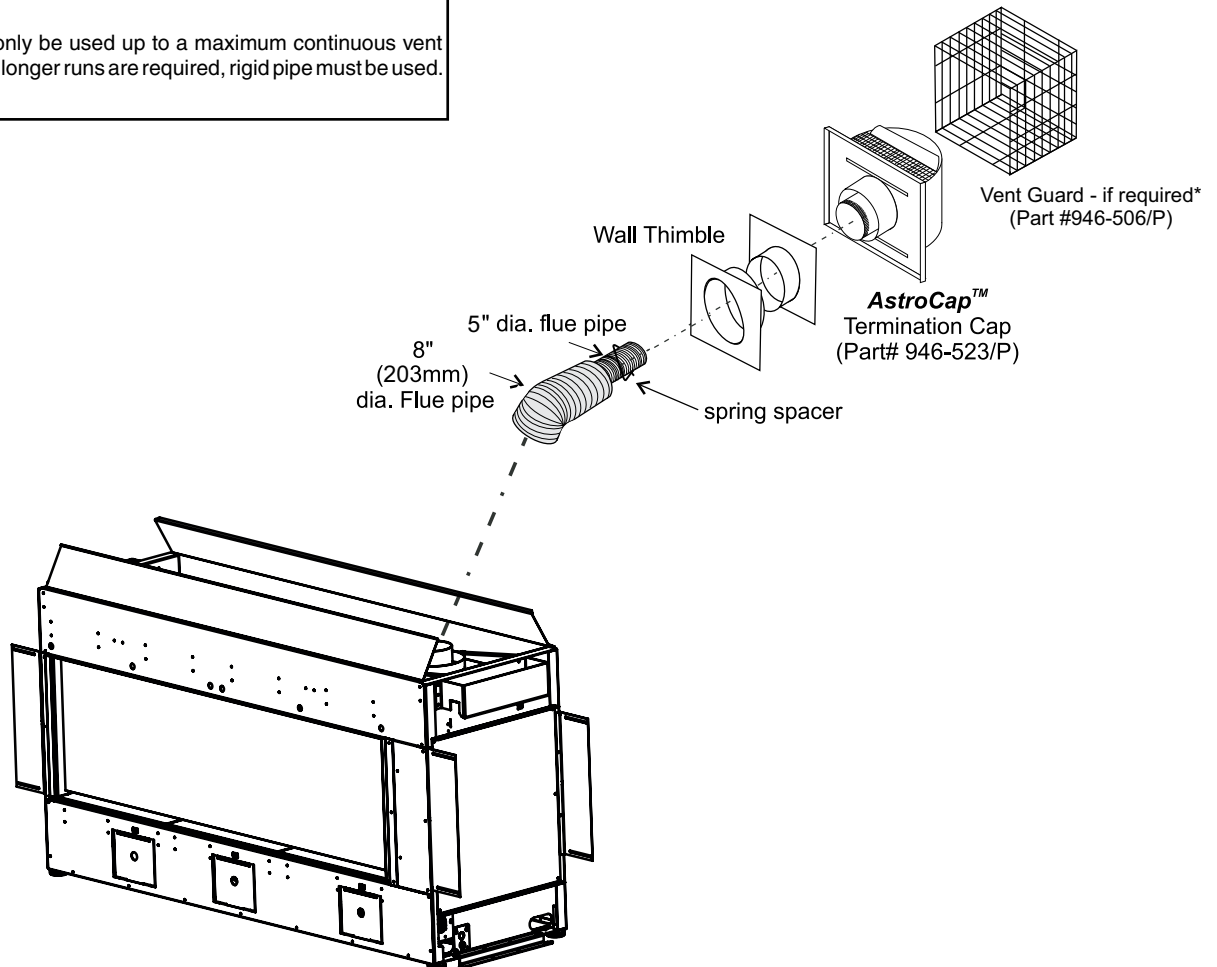

HORIZONTAL TERMINATIONS

Rigid Pipe 5" x 8" (127 mm x 203 mm)

Minimum components required for a basic horizontal termination:

- 1 Horizontal Termination Cap
- 1 Rigid Pipe Adaptor (770-994)
- 1 Wall Thimble
- 1 Length of pipe to suit wall thickness (see chart)

Wall thickness is measured from the back standoffs to the inside mounting surface of the termination cap. For siding other than vinyl, furring strips may be used instead of the vinyl siding standoff to create a level surface to mount the vent terminal. The terminal must not be recessed into the siding. When measuring wall thickness, include furring strips.

If a vinyl siding standoff is required (it must be used with vinyl siding), measure to the outside surface of the wall without siding and add two inches.

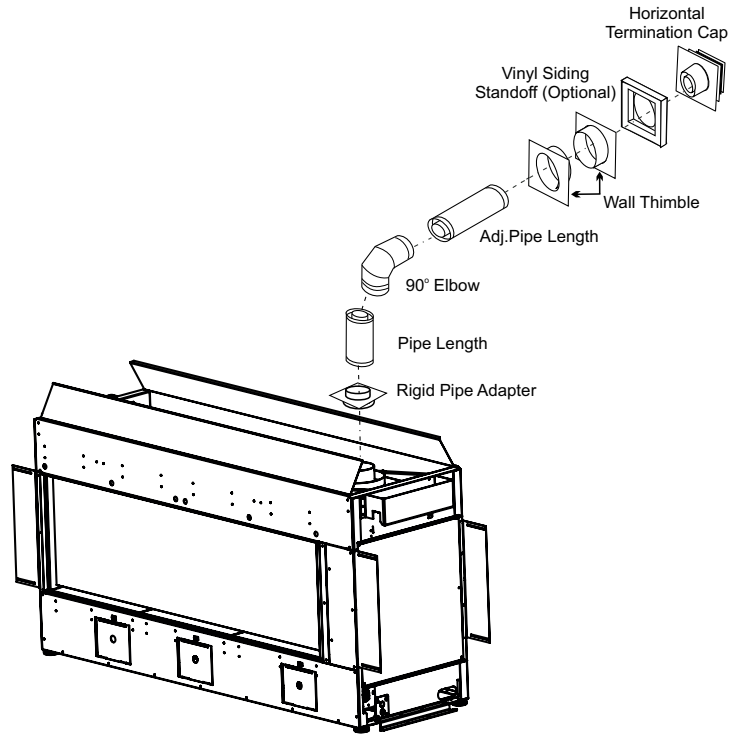

Flat Wall Installation	
Wall Thickness	Vent Length Required
4" (102 mm) - 5-1/2" (140 mm)	6" (152 mm)
7" (178 mm) - 8-1/2" (216 mm)	9" (229 mm)
10" (254 mm) - 11-1/2" (292 mm)	12" (305 mm)
9" (229 mm) - 14-1/2" (368 mm)	11" (279 mm) - 14-5/8" (371 mm) adj. pipe
15" (381 mm) - 23-1/2" (597 mm)	17" (432 mm) - 24" (610 mm) adj. pipe

WARNING • Do not combine venting components from different venting systems. However, use of the the AstroCap™ and FPI riser is acceptable with all systems.

When using rigid vent other than Simpson Dura-Vent, 3 screws must be used to secure rigid pipe to adaptor.

This product was evaluated by Intertek for using a Rigid Pipe Adaptor in conjunction with Duravent Direct-Vent, Selkirk Direct-Temp, Ameri Vent Direct Venting, ICC Excel Direct, Olympia Ventis DV, and Security Secure Vent systems. Use of these systems with the Rigid Pipe adaptor is deemed acceptable and does not affect the Intertek WHI listing of components.

The FPI AstroCap™ and FPI Riser Vent terminal are certified for installations using FPI venting systems as well as Simpson Dura-Vent® Direct Vent, American Metal Products Ameri Vent Direct Vent, Security Secure Vent®, ICC Excel, Olympia Ventis DV, Selkirk Direct-Temp. AstroCap™ is a proprietary trademark of FPI Fireplace Products International Ltd. Dura-Vent® and Direct Vent are registered and/or proprietary trademarks of Simpson Dura-Vent Co. Inc.

HORIZONTAL TERMINATIONS

5" X 8" (127 mm x 203 mm) Rigid or Flex Pipe

The diagrams below show examples of horizontal termination arrangements using one, two, or three 90° elbows (two 45° elbows equal one 90° elbow).

1. A maximum of three 90° elbows are permitted.
 2. Minimum distance between elbows is 1 ft. (305 mm).
- Maintain clearances to combustibles as listed in the "Clearances" section.
 - Horizontal vent must be supported every 3 feet (0.9 m).
 - Firestops are required at each floor level and whenever passing through a wall.
 - Must use optional rigid pipe adaptor (part# 770-994) when using rigid pipe vent systems.
 - A vent guard should be used whenever the termination is lower than the specified minimum or as per local codes.
 - Flex system can only be used up to 10 feet (3 m) - otherwise, rigid venting must be used.

Horizontal Venting with Two 90° Elbows

One 90° elbow = two 45° elbows.

Option	V (min.)	H + H1 (max.)	With these options, maximum total pipe length is 30 feet (9.1 m) with minimum of 6 feet (1.8 m) total vertical pipe and maximum 8 feet (2.4 m) total horizontal pipe. <i>A minimum of 1 ft. (610 mm) is required between all 90° elbows.</i>
A)	3' (914 mm)	4' (1.2 m)	
B)	4' (1.2 m)	5' (1.5 m)	
C)	5' (1.5 m)	6' (1.8 m)	
D)	6' (1.8 m)	8' (2.4 m)	
Restrictor Set 0 - Factory Setting			

Horizontal Venting with Three 90° Elbows

One 90° elbow = two 45° elbows.

Option	V (min.)	H (max.)	V + V1 (min.)	H + H1 (max.)	With these options, maximum total pipe length is 30 feet (9.1 m) with minimum of 12 feet (3.7 m) total vertical pipe and maximum 9 feet (2.7 m) total horizontal pipe. <i>A minimum of 1 ft. (610 mm) is required between all 90° elbows.</i>
A)	2' (610 mm)	2' (610 mm)	5' (1.5 m)	3' (0.9 m)	
B)	3' (0.9 m)	2' (610 mm)	7' (2.1 m)	5' (1.5 m)	
C)	4' (1.2 m)	3' (0.9 m)	9' (2.7 m)	6' (1.8 m)	
D)	5' (1.5 m)	4' (1.2 m)	10' (3 m)	7' (2.1 m)	
E)	6' (1.8 m)	5' (1.5 m)	11' (3.4 m)	8' (2.4 m)	
F)	7' (2.1 m)	6' (1.8 m)	12' (3.7 m)	9' (2.7 m)	
Restrictor Set 0 - Factory Setting					

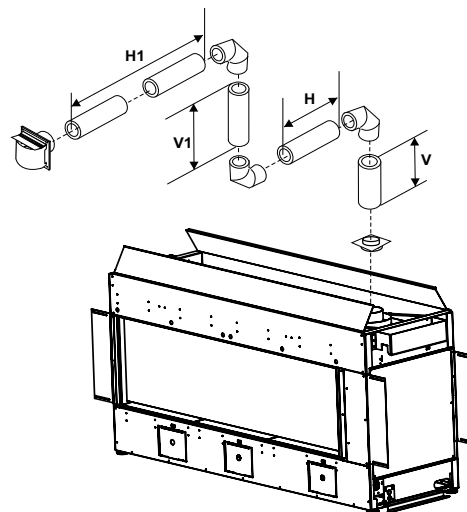
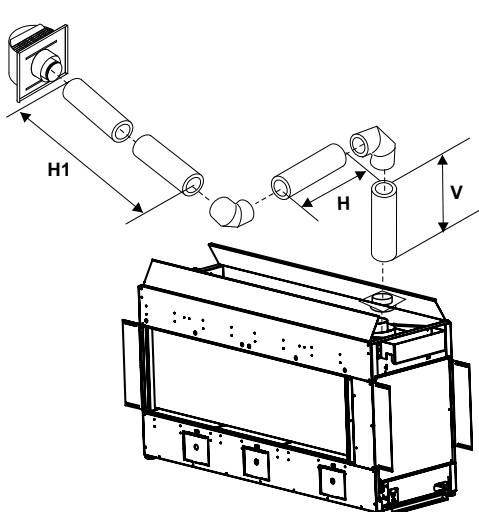

VENTING ARRANGEMENT - VERTICAL TERMINATIONS

5" x 8" (127 mm x 203 mm) Rigid and Flex Pipe

The shaded area in the diagram shows all allowable combinations of straight vertical and offset-to-vertical terminations, using two 90° elbows with rigid/flex pipe venting systems.

- Two 45° elbows equal to one 90° elbow.
- Vent must be supported at offsets.
- Minimum distance between elbows is 1 ft. (305 mm).
- Maintain clearances to combustibles as listed in the "Clearances" section.
- Horizontal vent must be supported every 3 feet (0.9 m).
- Firestops are required at each floor level and whenever passing through a wall.
- Must use optional rigid pipe adaptor (Part# 770-994) when using rigid pipe vent systems.
- Refer to the "Vent Restrictor Position" section for details on how to change the vent restrictor from the factory setting of Set 0 through to Set 5, if required.

For vertical terminations, the Regency Direct Vent Flex System may be used for installations with a maximum vent length of up to 40 feet including offsets. If longer runs are required, rigid pipe must be used. If no offsets are used, the maximum run is per the chart on this page.

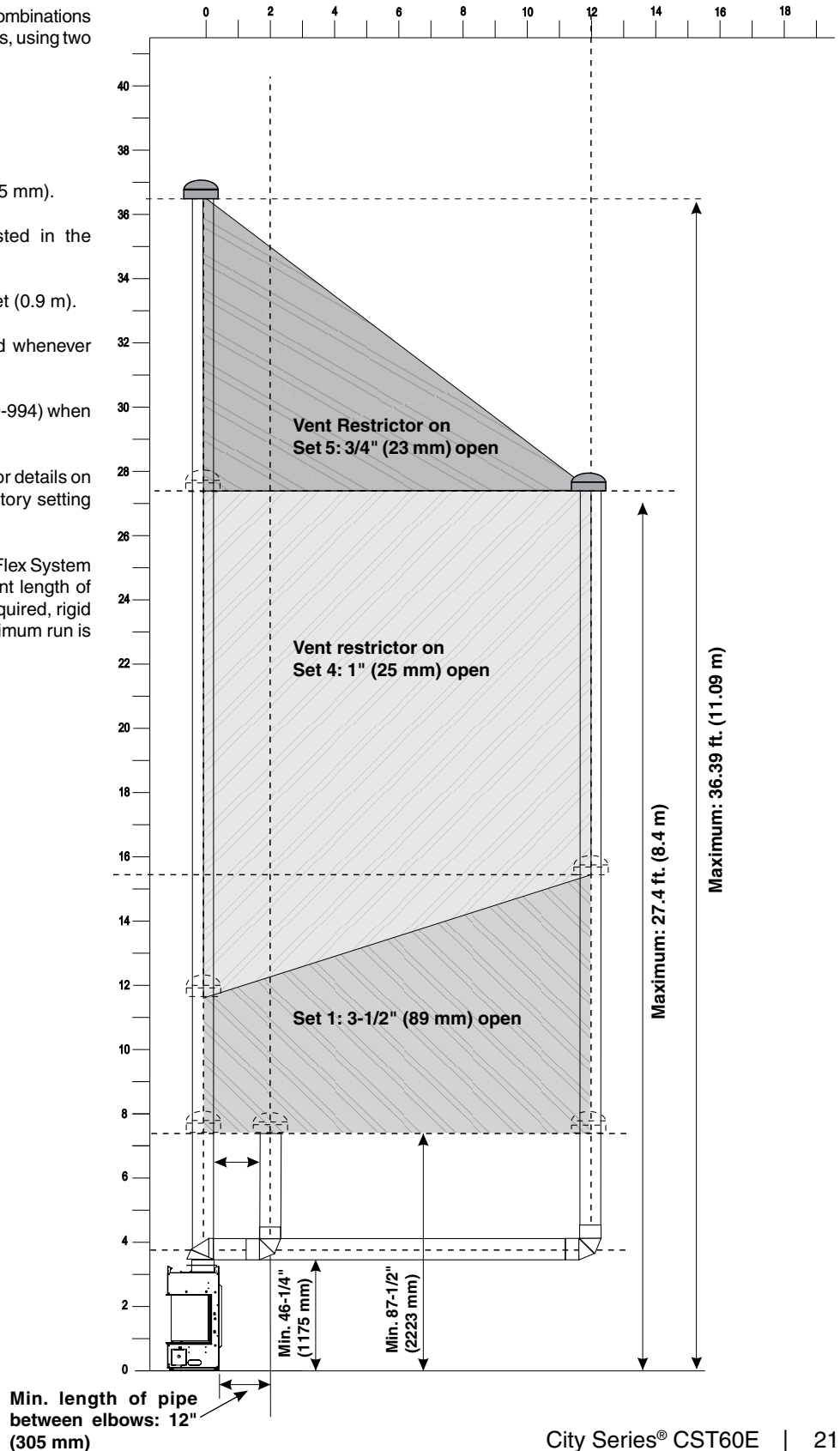

VERTICAL TERMINATIONS

5" x 8" (127 mm x 203 mm) Rigid Pipe

The minimum components required for a basic vertical termination are:

- 1 Vertical Termination Cap
- 1 Rigid Pipe Adaptor (770-994)
- 1 Ceiling Firestop
- 1 Flashing
- 1 Storm Collar
- 1 Length of pipes to suit wall thickness & vent run (see chart)

Galvanized pipe is desirable above the roofline due to its higher corrosion resistance. Continue to add pipe sections through the flashing until the height of the vent cap meets the minimum height requirements specified in the table below, or local codes. Note that for steep roof pitches, the vertical height must be increased. A poor draft, or down drafting, can result from high wind conditions near big trees or adjoining roof lines. In these cases, increasing the vent height may solve the problem.

Roof Pitch	Minimum Vent Height	
	Feet	Meters
flat to 7/12	2	0.6
over 7/12 to 8/12	2	0.6
over 8/12 to 9/12	2	0.6
over 9/12 to 10/12	2-1/2	0.76
over 10/12 to 11/12	3-1/4	1
over 11/12 to 12/12	4	1.2
over 12/12 to 14/12	5	1.5
over 14/12 to 16/12	6	1.8
over 16/12 to 18/12	7	2.1
over 18/12 to 20/12	7-1/2	2.3
over 20/12 to 21/12	8	2.4

WARNING

- Do not combine venting components from different venting systems. However, use of the the AstroCap™ and FPI Riser is acceptable with all systems.

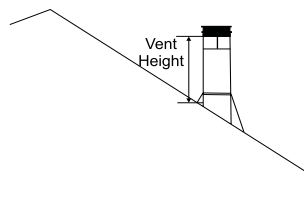
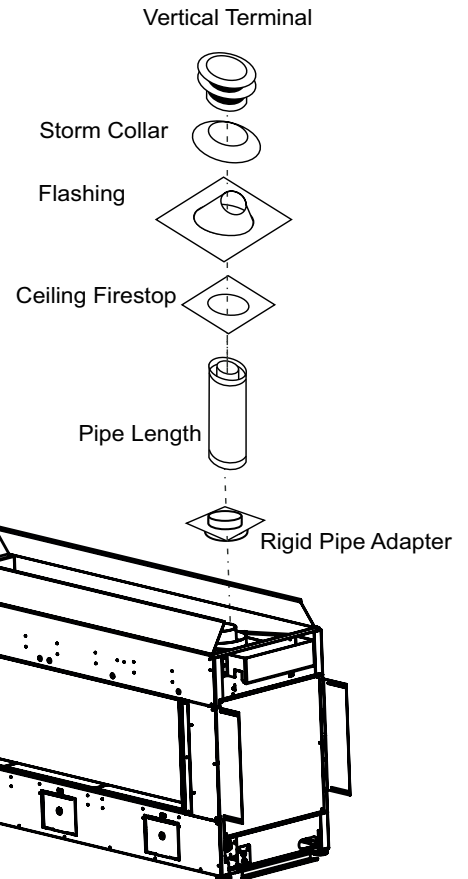

When using Rigid Vent other than Simpson Dura-Vent, 3 screws must be used to secure rigid pipe to adaptor.

This product was evaluated by Intertek for using a Rigid Pipe Adaptor in conjunction with Duravent Direct-Vent, Selkirk Direct-Temp, Ameri Vent Direct Venting, ICC Excel Direct, Olympia Ventis DV, and Security Secure Vent systems. Use of these systems with the Rigid Pipe adaptor is deemed acceptable and does not affect the Intertek WHI listing of components.

The FPI AstroCap™ and FPI Riser Vent terminal are certified for installations using FPI venting systems as well as Simpson Dura-Vent® Direct Vent, American Metal Products Ameri Vent Direct Vent, Security Secure Vent®, ICC Excel, Olympia Ventis DV, Selkirk Direct-Temp. AstroCap™ is a proprietary trademark of FPI Fireplace Products International Ltd. Dura-Vent® and Direct Vent are registered and/or proprietary trademarks of Simpson Dura-Vent Co. Inc.

VERTICAL TERMINATIONS

Vertical Terminations - 5" x 8" (127 mm x 203 mm) Rigid or Flex Pipe

- Two 45° elbows equal to one 90° elbow. Maximum of six 45° elbows allowed.
- Vent must be supported at offsets.
- Minimum distance between elbows is 1 ft. (305mm).
- Maintain clearances to combustibles as listed in the "Clearances" section.
- Horizontal vent must be supported every 3 feet (0.9 m).
- Firestops are required at each floor level and whenever passing through a wall.
- Must use optional rigid pipe adaptor (part# 770-994) when using rigid pipe vent systems.

Vertical Venting with Three (3) 90° Elbows

One 90° elbow = Two 45° elbows.

Option	V (min.)	H + H1 (max.)	V + V1 (min.)
A)	1' (305 mm)	2' (610 mm)	3' (0,9 m) Min.
B)	2' (610 mm)	3' (0.9 m)	4' (1,2 m) Min.
C)	3' (0.9 m)	4' (1.2 m)	6' (1,8 m) Min.
D)	4' (1.2 m)	5' (1.5 m)	7' (2,1 m) Min.
E)	5' (1.5 m)	6' (1.8 m)	8' (2,4 m) Min.
F)	6' (1.8 m)	7' (2.1 m)	9' (2,7 m) Min.
G)	7' (2.1 m)	8' (2.4 m)	10' (3 m) Min.

Lengths do not include elbow indicated
Restrictor Set 0 - Factory Setting

- NOTES**
- For horizontal terminations, the Regency DirectVent Flex System may be used for installations with a maximum continuous vent length of 10 feet (3 m). If longer runs are required, rigid pipe must be used. With these options, max. total pipe length is 30 feet (9.1 m) with min. of 10 feet (3 m) total vertical pipe and max. 8 feet (2.4 m) total horizontal pipe.
 - A minimum of 1 ft. (610 mm) is required between all 90° elbows.

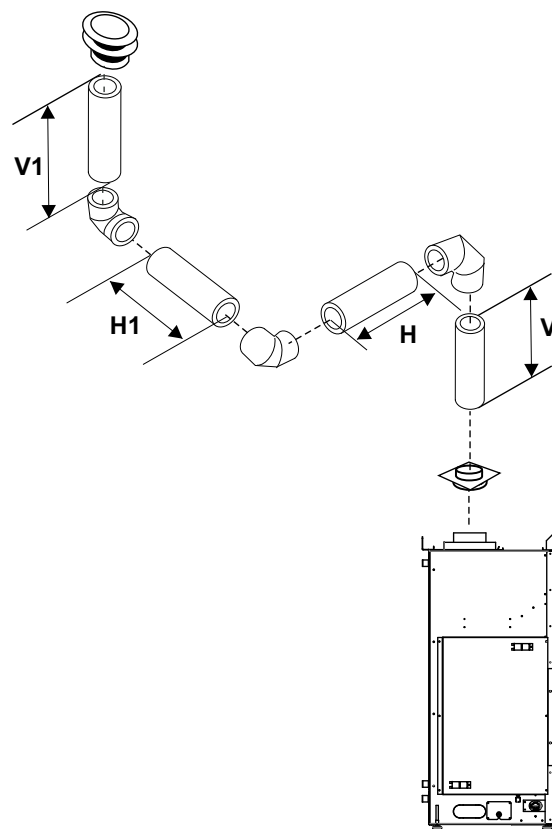

VENTING INTRODUCTION - POWER VENT

IMPORTANT

- **The instructions contained in this manual must be read carefully prior to installation of this appliance.**
- **120 Volt AC power is required for this appliance to operate. A receptacle box, receptacle, and cover are provided. See the "Wiring the Unit" section in this manual. Electrical power must be brought to the appliance by a licensed electrician.**

The CST60E power vent system is designed to allow the installation of this gas appliance when typical vent configurations (shown in this manual) are not possible due to excessive offsets, long or negative vent runs, etc.

When installed as a power vent appliance, this unit is designed to use flex or rigid venting.

This unit comes with a 5" (127 mm) inner and 8" (203 mm) outer collar which must be reduced to 4" x 6 5/8" (102 mm x 168 mm) in all applications when installed as a power vent.

The vent pipe must always be reduced to 4 x 6 5/8" venting using a reducer for either the flex vent or rigid vent. See below.

RIGID PIPE: MUST USE RIGID PIPE ADAPTOR 770-994 AND 946-606 PIPE REDUCER TO 4" X 6 5/8" (102 mm - 168 mm)

FLEX VENT: MUST USE REDUCER 946-758 TO 4" X 6 5/8" (102 mm - 168 mm)

NOTES

- Rigid pipe is approved for up to 72 feet (21.95 m).
- Flex pipe is approved for up to 40 feet (12.19 m) using 2 X 946-756-- 20 foot (6.10 m) flex kits.

There are two options available when installing this unit as a power vent appliance:

- End of line flush horizontal power vent system: flush power vent fan acts as the termination cap and sits flush to the outside wall. Allowed for horizontal termination only.
- Inline power vent system: power vent fan terminal is incorporated into the vent run - allows for both horizontal and vertical termination.

No vent restrictor is required when installed as a power vent system.

This unit may be terminated vertically or horizontally. See the following pages for various vent configurations using rigid or flex & vertical or horizontal terminations. The instructions contained in this manual must be read carefully prior to installation.

Horizontal Terminations - Inline Horizontal Vent Chart

RIGID PIPE: MUST USE RIGID PIPE ADAPTOR 770-994 AND 946-606 PIPE REDUCER TO 4" X 6 5/8" (102 mm x 168 mm).
 FLEX VENT: MUST USE REDUCER 946-758 TO 4" X 6 5/8" (102 mm x 168 mm).

- NOTES**
- Rigid pipe is approved for up to 72 feet (22 m).
 - Flex pipe is approved for up to 40 feet (12.2 m) using two 20 foot (6.1 m) flex kits (part # 946-756).
 - This model comes with a 5" (127 mm) inner and an 8" (203 mm) outer collar which must be reduced to 4" x 6-5/8" (102 mm x 168 mm) in all applications.
 - Must be terminated horizontally. Vertical terminations are not permitted.

The gas power vent system is designed to allow the installation of a gas appliance when typical vent configurations (shown in this manual) are not possible.

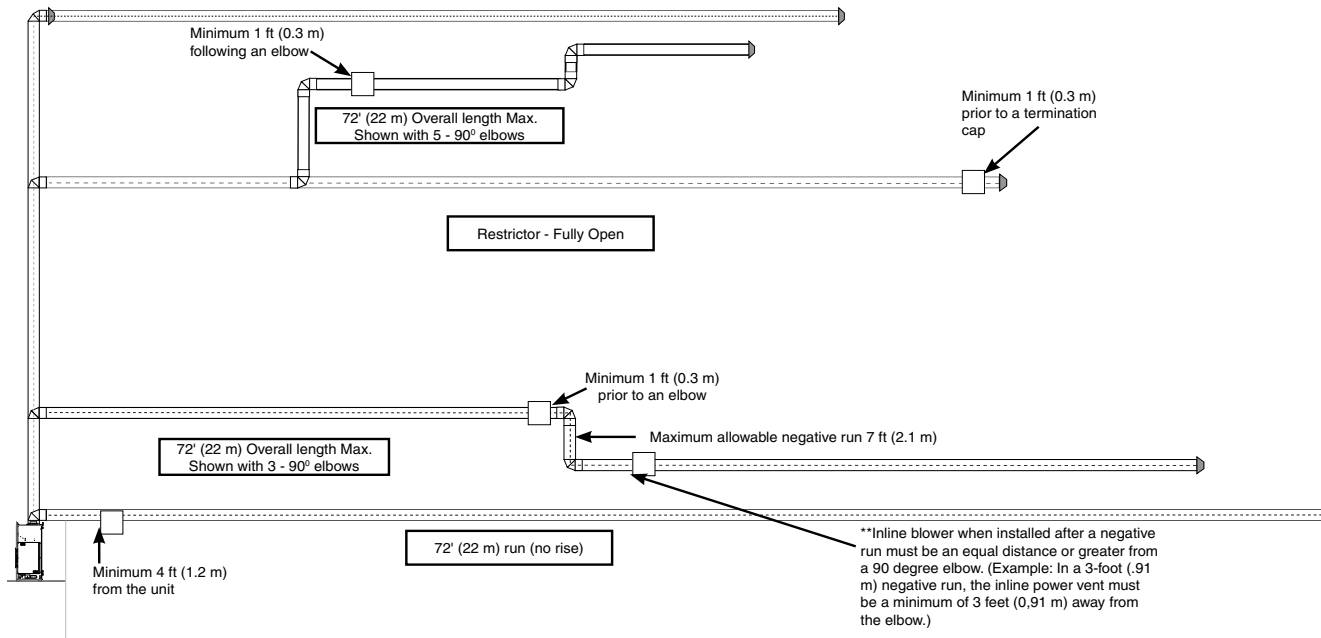

- IMPORTANT**
- **Maximum total vent length (based on overall length of combined chimney components) = 72' (22 m)**
 - **Maximum total negative vent length = 7' (2.1 m).**
 - **Do not run positive venting after a negative run.**
 - **Maximum of six - 90° elbows permitted.**
 - **One 90° elbow = two 45° elbows.**
 - **Minimum 4' (1.2 m) from the unit prior to terminating.**

Inline power vent location restrictions:
 Minimum 4 ft (1.2 m) from the unit
 Minimum 1 ft (0.3 m) prior to an elbow.
 Minimum 1 ft (0.3 m) following an elbow.
 Minimum 1 ft (0.3 m) prior to a termination cap.
 When the inline blower is installed after a negative run, for every foot of negative run the inline blower must be an equal distance or greater from the 90-degree elbow. See example above.

Vent Restrictor Position

No vent restrictor required.

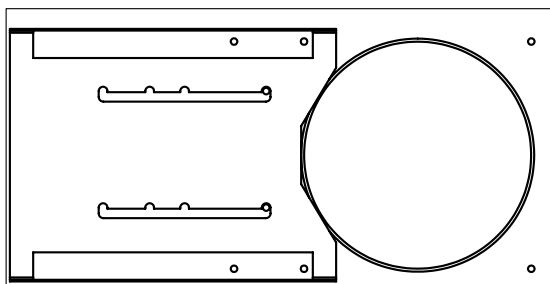

Set 0
 Fully open
 Factory Set

Horizontal Terminations - Inline Horizontal Vent Chart

RIGID PIPE: MUST USE RIGID PIPE ADAPTOR 770-994 AND 946-606 PIPE REDUCER TO 4" X 6 5/8" (102 mm x 168 mm).
 FLEX VENT: MUST USE REDUCER 946-758 TO 4" X 6 5/8" (102 mm x 168 mm).

- NOTES**
- Rigid pipe is approved for up to 72 feet (22 m).
 - Flex pipe is approved for up to 40 feet (12.2 m) using two 20 foot (6.1 m) flex kits (part # 946-756).
 - This model comes with a 5" (127 mm) inner and an 8" (203 mm) outer collar which must be reduced to 4" x 6-5/8" (102 mm x 168 mm) in all applications.
 - Must be terminated horizontally. Vertical terminations are not permitted.

The gas power vent system is designed to allow the installation of a gas appliance when typical vent configurations (shown in this manual) are not possible.

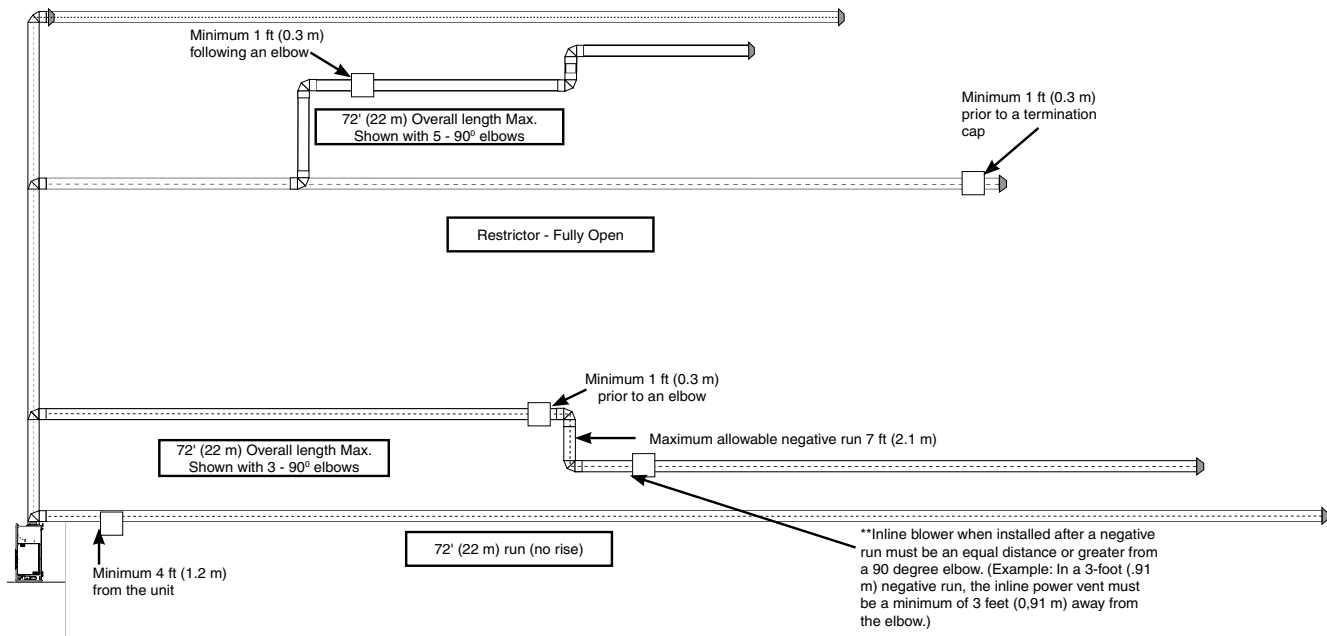

- IMPORTANT**
- **Maximum total vent length (based on overall length of combined chimney components) = 72' (22 m)**
 - **Maximum total negative vent length = 7' (2.1 m).**
 - **Do not run positive venting after a negative run.**
 - **Maximum of six - 90° elbows permitted.**
 - **One 90° elbow = two 45° elbows.**
 - **Minimum 4' (1.2 m) from the unit prior to terminating.**

Inline power vent location restrictions:
 Minimum 4 ft (1.2 m) from the unit
 Minimum 1 ft (0.3 m) prior to an elbow.
 Minimum 1 ft (0.3 m) following an elbow.
 Minimum 1 ft (0.3 m) prior to a termination cap.
 When the inline blower is installed after a negative run, for every foot of negative run the inline blower must be an equal distance or greater from the 90-degree elbow. See example above.

Vent Restrictor Position

No vent restrictor required.

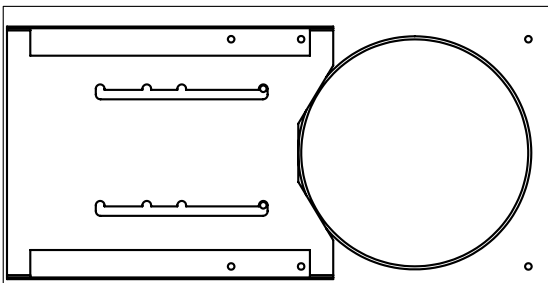

Set 0
 Fully open
 Factory Set

Horizontal Terminations - End of Line Horizontal Vent Chart

RIGID PIPE: MUST USE RIGID PIPE ADAPTOR 770-994 AND 946-606 PIPE REDUCER TO 4" X 6 5/8" (102 mm x 168 mm).

FLEX VENT: MUST USE REDUCER 946-758 TO 4" X 6 5/8" (102 mm x 168 mm).

NOTES

- Rigid pipe is approved for up to 72 feet (22 m).
- Flex pipe is approved for up to 40 feet (12.2 m) using two 20 foot (6.1 m) flex kits (part # 946-756).
- This model comes with a 5" (127 mm) inner and an 8" (203 mm) outer collar which must be reduced to 4" x 6-5/8" (102 mm x 168 mm) in all applications.
- Must be terminated horizontally. Vertical terminations are not permitted.

The gas power vent system is designed to allow the installation of a gas appliance when typical vent configurations (shown in this manual) are not possible.

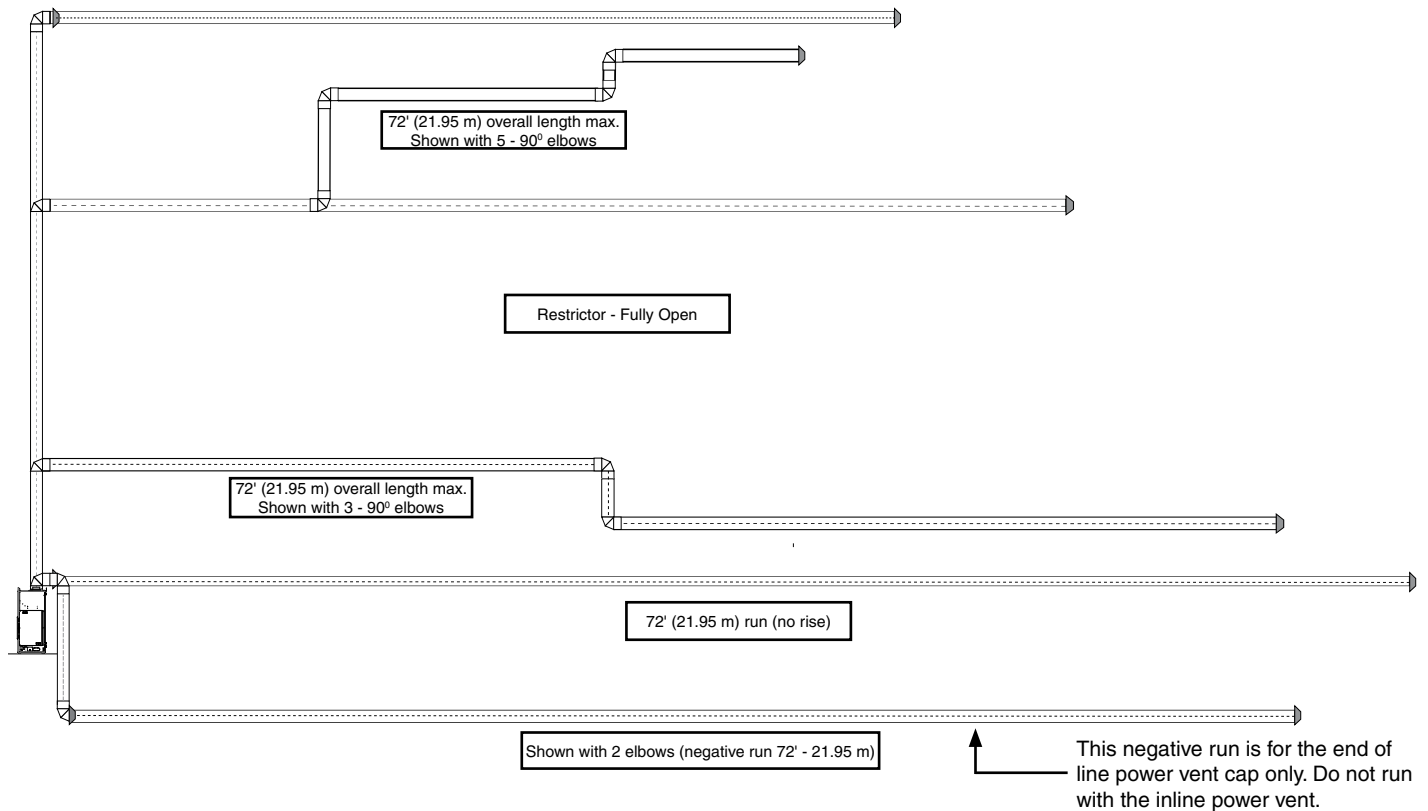

IMPORTANT

- **Maximum total vent length (based on overall length of combined chimney components) = 72' (21.95 m)**
- **Maximum total negative vent length = 7' (2.1 m).**
- **Do not run positive venting after a negative run.**
- **Maximum of six - 90° elbows permitted.**
- **One 90° elbow = two 45° elbows.**
- **Minimum 4' (1.2 m) from the unit prior to terminating.**

Vent Restrictor Position

No vent restrictor required.

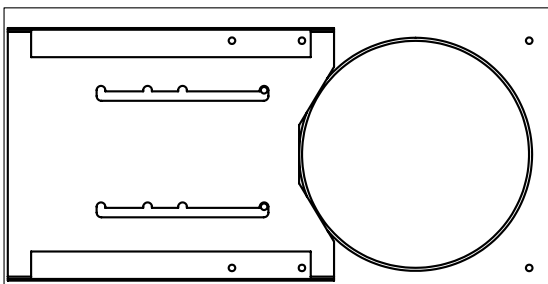

Set 0
Fully open
Factory Set

Venting Arrangement for Vertical Terminations - Inline Power Vent

Vertical venting with straight vertical venting and or with a max. of six (6) 90° Elbows (1 - 90° = 2 - 45°)

- NOTES**
- Rigid pipe is approved for up to 72 feet (22 m).
 - Flex pipe is approved for up to 40 feet (12.2 m) using two 20 foot (6.1 m) flex kits (part # 946-756).

- Two 45° elbows equal to one 90° elbow.
- Vent must be supported at offsets.
- Minimum distance between elbows is 1 ft. (0.3 m).
- Maintain clearances to combustibles as listed in the "Clearances" section.
- Horizontal vent must be supported every 3 feet (0.91 m).
- Firestops are required at each floor level and whenever passing through a wall.

Restrictor set on 0 (fully open) regardless of vent run.

Inline power vent location restrictions:

- Minimum 4 ft (1.2 m) from the unit.
- Minimum 1 ft (0.3 m) prior to an elbow.
- Minimum 1 ft (0.3 m) following an elbow.
- Minimum 2 ft (0.6 m) prior to a termination cap.
- Minimum 2 ft. from inline PV to termination cap.
- Minimum 4' from top of unit to inline PV.
- Max. of 72' (22 m), using up to six 90° elbows
- (Example shows two 90° elbows).
- No negative runs.

- NOTE**
- The inline power vent must be installed within the confines of the home/structure.

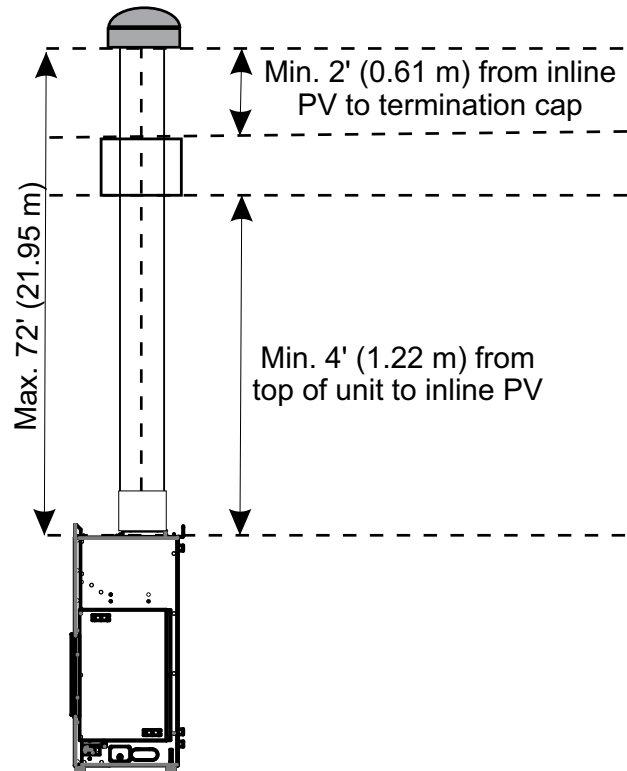

Max. of 72' (21.95 m), using up to six 90° elbows
(Note: two 90° elbows shown.)

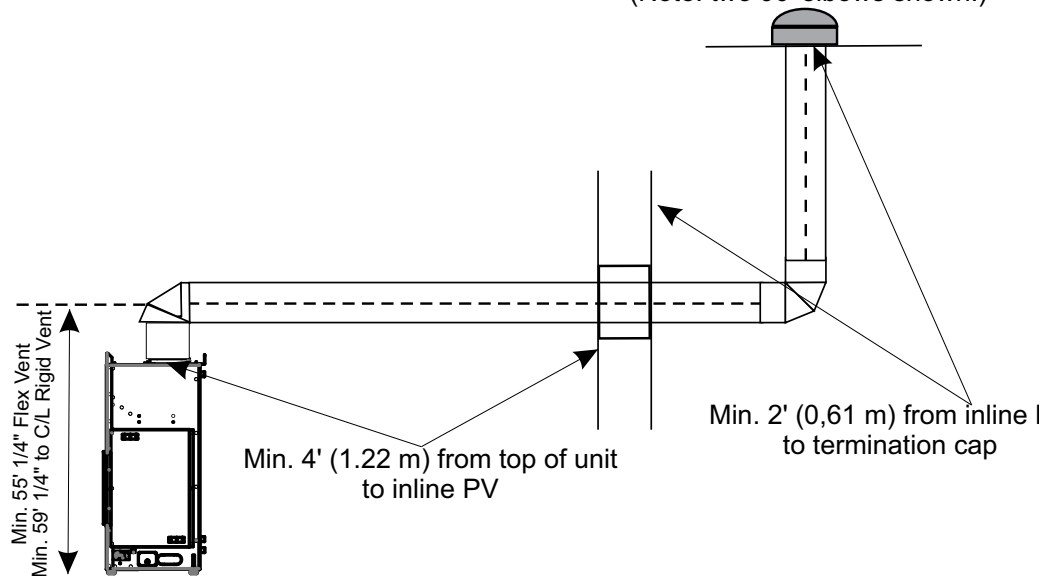

Vertical Terminations - Flex Pipe

FLEX VENT: MUST USE REDUCER 946-758 TO 4" X 6 5/8" (102 mm x 168 mm)

NOTE • Flex pipe is approved for up to 40 feet (12.2 m) using one 20 foot (6.1 m) flex kit (part # 946-755) and one 20 foot (6.1 m) flex kit extension (part # 946-756).

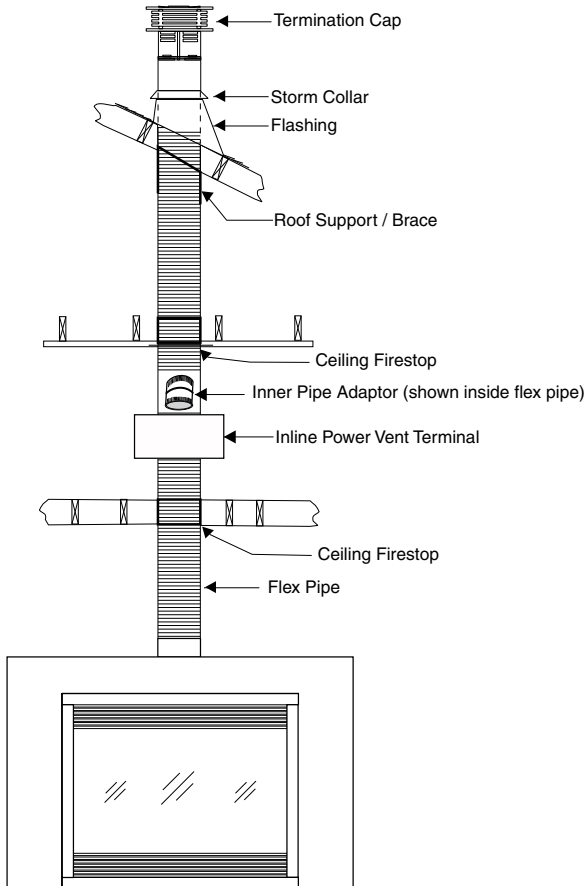

Inline power vent location restrictions:

- Minimum 4 ft (1.2 m) from the unit.
- Minimum 1 ft (0.3 m) prior to an elbow.
- Minimum 1 ft (0.3 m) following an elbow.
- Minimum 2 ft (0.6 m) prior to a termination cap.
- Minimum 2 ft (0.6 m) from inline PV to termination cap.
- Minimum 4ft (1.2 m) from top of unit to inline PV.
- Max. of 72' (22 m), using up to six 90° elbows
- (Note: example shows two 90° elbows).
- No negative runs.

Power Vent Kit (Part #666-945)

- 1 666-945 Power vent kit sold separately.
- 1 946-219/P Adaptor pipe included w/power vent kit.
- 1 946-755 20' (6.1 m) Vertical Flex Kit (sold separately) includes: 20 ft. (6.10 m) flex pipe with 10 spacers (inner & outer pipe), 3 wall straps, ceiling firestop, roof brace, flex to rigid adaptor, roof support/brace, 36 in. (914 mm) rigid Duravent pipe, storm collar, high wind termination cap, hardware.
- 1 Max. 946-756 20' (6.1 m) flex kit extension (sold separately).
- 1 946-758 Reducer (required - sold separately).
- 1 Power vent fan included w/power vent kit.
- 1 911-250/P 45' (13.7 m) 5-wire BX cable (sold separately).
- OR
- 1 911-251/P 90' (27.4 m) 5-wire BX cable (sold separately).

Must also purchase one of the flashings listed below:

- 1 46DVA-F12 Flashing 7/12 - 12/12
- 1 46DVA-F6 Flashing 0/12 - 6/12
- 1 46DVA-FF Flat roof flashing